

TCL

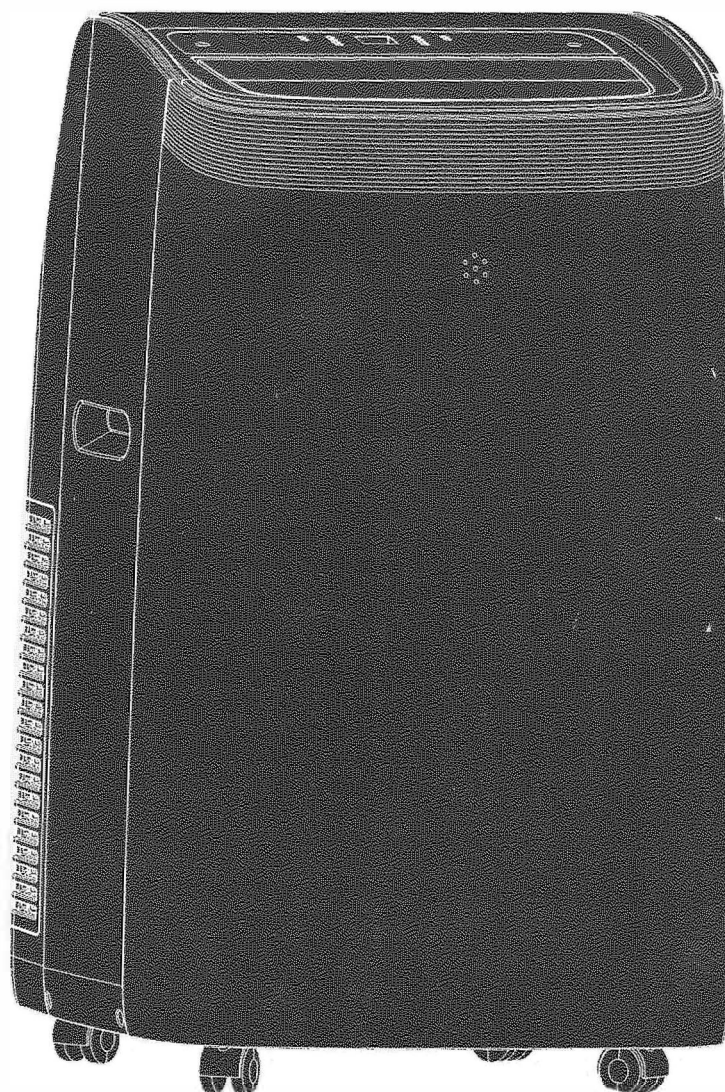

MZ Portable Air Conditioner

Please read this manual carefully before operating your unit and retain for future reference.

814100131

IMPORTANT SAFETY INSTRUCTIONS

Before installing and using your air conditioner, please read this owner's manual carefully. Store this manual in a safe place for future reference. Your safety and the safety of others is very important to us. Please pay attention to all safety messages outlined in this owner's manual.

WARNING: To reduce the risk of fire, electrical shock or injury when using your air conditioner, follow the following basic precautions:

ELECTRICAL REQUIREMENTS

The electrical ratings for your air conditioner are listed on the model and serial number label located on the front right side of the unit (when facing the front).

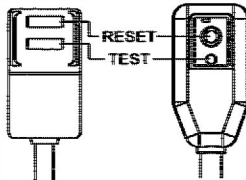
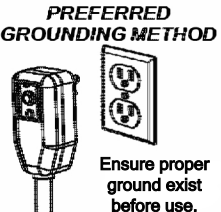
WARNING		Specific electrical requirements are shown in the diagram below. Follow the requirements below for the type of plug on the power supply cord.	
Electrical Shock Hazard	Wiring Requirements	Power Supply Cord	
<p>Plug into a grounded 3 prong outlet. Do not remove the ground prong. Do not use an adapter. Do not use an extension cord. Failure to follow these instructions can result in death, fire, or electrical shock.</p>	<p>60Hz, 115V AC outlet protected by a 15 amp time delay fuse or circuit breaker.</p>		<p>PREFERRED GROUNDING METHOD</p> 

RECOMMENDED GROUND METHOD

For your personal safety, this air conditioner must be grounded. This air conditioner is equipped with a 3 prong power supply cord with a grounded plug. To minimize the possibility of electrical shock, the cord must be plugged into a 3 prong outlet and grounded in accordance with all local codes and ordinances. If a 3 prong outlet is not available, it is the customer's responsibility to have a properly grounded 3 prong outlet installed by a qualified electrician.

INSTALLATION MANUAL --- Important considerations

When compared with other refrigerants, R32 is more environmentally friendly. Please use this product as instructed. This refrigerant is flammable and may combust under certain conditions, however when this product is used as directed these risks are significantly reduced. Always consult with a trained professional when maintaining or repairing an air conditioner.

Warning

- Please read the manual before installing, using, or conducting maintenance.
- Do not use means to accelerate the defrosting process or to clean, other than those recommended by the manufacturer.
- Be aware that refrigerants may not contain an odor.
- Do not pierce or burn the appliance.
- The appliance shall be stored in a room without continuously operating sources (for example: open flames, an operating ignition gas appliance or an operating electric heater).
- Please contact a service center when maintenance is necessary. At the time of maintenance, the maintenance personnel must strictly comply with the Operation
- Manual provided by the corresponding manufacturer and any non-professional is prohibited to maintain the air conditioner.
- It is necessary to comply with the provisions of gas-related federal, state, and local laws and regulations.
- It is necessary to clear away the refrigerant in the system when maintaining or recycling an air conditioner by a trained professional.



Warning: flammable
& Dangerous

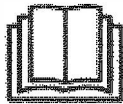

Read the user manual

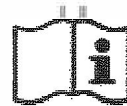

Read the installation
manual



Read the
service manual

Important Considerations

- **The air conditioner you buy must be installed by professional personnel** and the "Installation manual" is used only for the professional installation personnel!
- The installation specifications should be subject to our after-sale service regulations.
- When filling the flammable refrigerant, please use caution to avoid serious injury.
- A leak test must be done after the installation is completed.
- It is a must to perform the safety inspection before maintaining or repairing an air conditioner using flammable refrigerant in order to ensure that the fire risk is reduced to a minimum.
- Requirements for the total weight of filled refrigerant and the area of a room to be equipped with an air conditioner (are shown as in the following Tables GG.1 and GG.2)



The maximum charge and the required minimum floor area

$m_1 = (4 \text{ m}^3) \times \text{LFL}$, $m_2 = (26 \text{ m}^3) \times \text{LFL}$, $m_3 = (130 \text{ m}^3) \times \text{LFL}$

Where LFL is the lower flammable limit in kg/ m³, R290 LFL is 0.038 kg/ m³, R32 LFL is 0.038 kg/ m³.

For the appliances with a charge amount $m_1 < M = m_2$:

The maximum charge in a room shall be in accordance with the following: $m_{\text{max}} = 2.5 \times (\text{LFL})^{(5/4)} \times h_0 \times (A)^{1/2}$

The required minimum floor area A_{min} to install an appliance with refrigerant charge M (kg) shall be in accordance with following: $A_{\text{min}} = (M / (2.5 \times (\text{LFL})^{(5/4)} \times h_0))^2$

Where:

m_{max} is the allowable maximum charge in a room, in kg;

M is the refrigerant charge amount in appliance, in kg;

A_{min} is the required minimum room area, in m²;

A is the room area, in m²;

LFL is the lower flammable limit, in kg/m³;

h_0 is the installation height of the appliance, in meters for calculating m_{max} or A_{min} , 1.8 m for wall mounted;

Table GG.1 - Maximum charge (kg)

Category	LFL (kg/m ₃)	h ₀ (m)	Floor area (m ₂)						
			4	7	10	15	20	30	50
R32	0,306	0,6	0,68	0,9	1,08	0,32	1,53	1,87	2,41
		1	1,14	1,51	1,8	2,2	2,54	3,12	4,02
		1,8	2,05	2,71	3,24	3,97	4,58	5,61	7,254
		2,2	2,5	3,31	3,96	4,85	5,6	6,86	8,85

Table GG.2 - Minimum room area (m2)

Category	LFL (kg/m ₃)	h ₀ (m)	Charge amount (M) (kg) Minimum room area (m2)						
			1,224 kg	1,836 kg	2,448 kg	3,672 kg	4,896 kg	6,12 kg	7,956 kg
R32	0,306	0,6		29	51	116	206	321	543
		1		10	19	42	74	116	196
		1,8		3	6	13	23	36	60
		2,2		2	4	0	15	24	40

Installation Safety Principles

1. Site Safety

Open Flames Prohibited



Ventilation Necessary



2. Operation Safety

Mind Static Electricity



Open Flames Prohibited

Must wear protective clothing and anti-static gloves

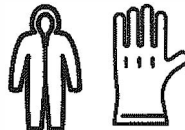

(Not included)

Don't use mobile phone



3. Installation Safety

- Refrigerant Leak Detector
- Appropriate Installation Location







The left picture is the schematic diagram of a refrigerant leak detector.

Please note that:

1. The installation site should be in a well-ventilated area.
2. The sites for installing and maintaining an air conditioner using Refrigerant R32 should be free from open fire or welding, smoking, drying oven or any other heat source higher than 548°C which easily produces open fire.
3. When installing an air conditioner, it is necessary to take appropriate anti-static measures such as wear anti-static clothing and/or gloves.
4. Installation or maintenance location should not be surrounded by obstacles or close to any heat source, flammable, and/or explosive areas or objects.
5. If the product suffers refrigerant leak during the installation, all personnel should go out till the refrigerant leaks completely for 15 minutes. If the product is damaged, a professional must carry such damages product back to the maintenance station. It is prohibited to weld the refrigerant pipe or conduct other operations on the contaminated site.
6. The air conditioner unit needs to sit on a flat even surface.
7. It is necessary to avoid the places where there are other electrical products, power switch plugs and sockets, kitchen cabinet, bed, sofa and other valuables directly under the lines on two sides of the indoor unit.
8. Any ventilation openings of unit should be free from obstructions.

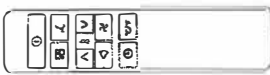
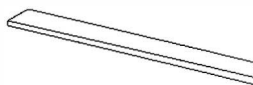
What's in the Box

APPEARANCE	PART NAME
	Exhaust Hose Hose Outlet Hose Inlet
	Window Slider Kit (extends up to 59.37")
	Remote Control (Batteries not included)
	Foam Insulation
	Drain Hose

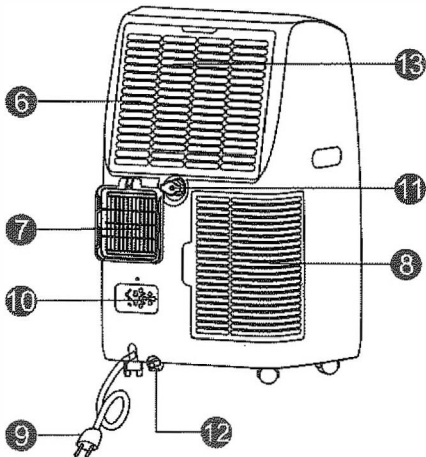
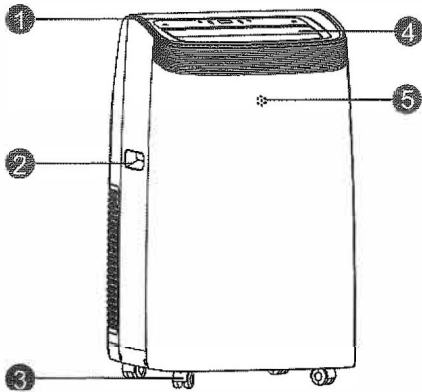

NO.	COMPONENT DESCRIPTION
1	Control Panel
2	Handle (both sides)
3	Wheels
4	Air Outlet Grille
5	Remote Control Receiver
6	Air Filter
7	Air Exhaust
8	Intake Grille
9	Power Cord
10	Plug Fixer
11	Middle Drainage
12	Condenser Drain

Note: The images shown here is for illustrative purposes only and may be subject to change, Accessory type and quantity may vary depending on the model.

Let's Get Started!

Installation & Assembly Instructions

Step 1: Assemble and Attach the Exhaust Hose

- Extend both sides of the hose. (Fig. 1a)
- Screw on the hose inlet (Fig. 1b)
- Screw on the hose outlet (Fig. 1c)
- Attach the exhaust hose by sliding the hose inlet from the top down into the air outlet grille. (Fig. 1d)

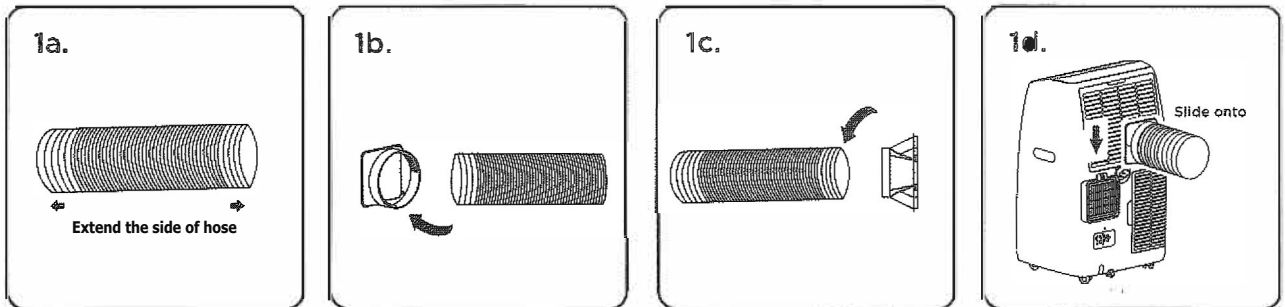

Step 2: Window Slider Kit Installation

Parts Needed:

- A. Panel (x2)
- B. Panel with one hole
- C. Screw or plastic pin

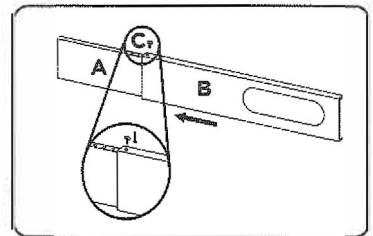
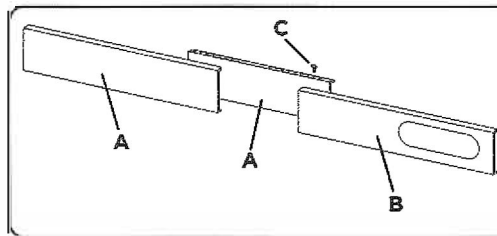

Assembly

1. Slide Panel A into Panel B and size to window width (use second Panel A if necessary). Windows sizes vary. When sizing the window width, be sure that the window kit assembly is free from gaps when taking measurements. If necessary, cut Panel B down to size. Cut on the side opposite the hole.
2. Lock the screw into the holes that correspond with the width that your window requires to ensure that there are no gaps in the window kit assembly after installation.
3. Use the provided foam seal to fill in any gaps.

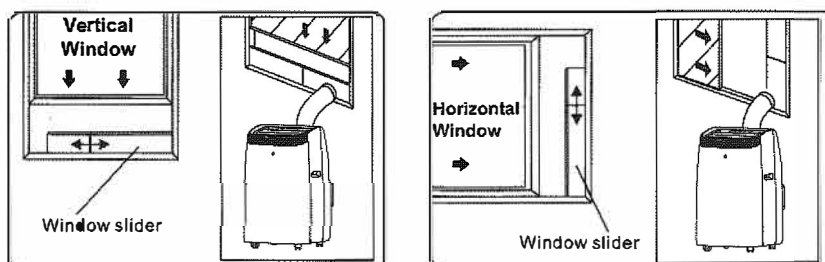
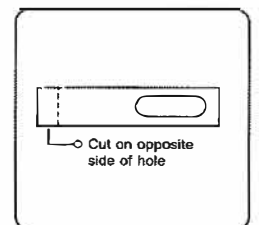

4. Attach the hose outlet to the window slider kit.

The image shown here is for illustrative purposes only and may be subject to change.

How to Control Your AC

All the basics you need to know to stay cool!

Control panel

The control panel is on the top of the appliance and enables you to control it without the remote control.

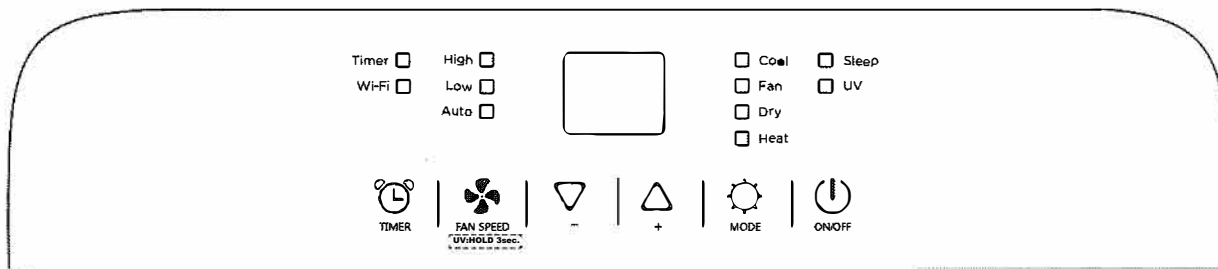
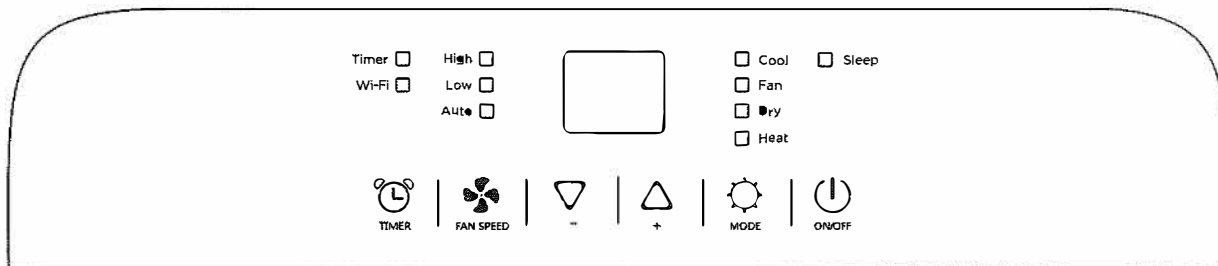
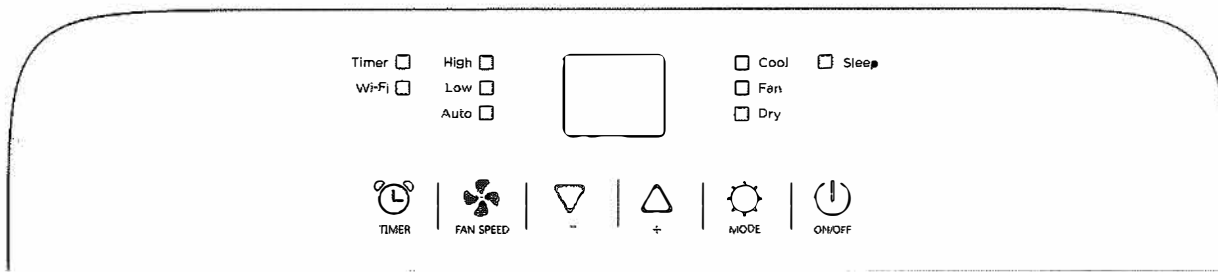



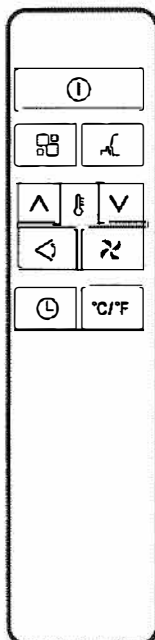





Note: The remote control vary depend of model: The buttons on the remote control may have a different name or location than the remote control shows in this manual.



REMOTE CONTROL	
	On/Off
	Increase
	Decrease
	Timer
	Unit Switch
	Fan Speed
	Mode
	Swing
	Sleep

Note: The images shown here are for illustrative purposes only and may be subject to change, the actual descriptions of control panel and their locations may vary depending on the model.

1. **Power button** - press the  on the control panel or the remote control to turn the air conditioner on and off. Never turn the appliance off by unplugging from the power source. Always press the Power button, then wait for a few minutes before unplugging. This allows the appliance to perform a proper shutdown.
2. **Cool Mode** - press the  on the control panel or remote until the Cool mode is lit. Select the target temperature 18° - 32°(64°-90°) by pressing the  or  button until the corresponding value is displayed. Select the required fan speed by pressing the fan speed button.
3. **Dry Mode** - press the  on the control panel or remote until the Dry symbol appears, “dh” will appear on the display. In this model, the default fan speed is low, and cannot be selected.
4. **Fan Mode** - press the  on the control panel until the Fan symbol appears. You can then select you desired fan speed, either High  or Low .
5. **Sleep Mode** - press the Sleep button on the remote control (there is no sleep mode on the control panel). This function is useful when you are sleeping as it gradually reduces operation of the appliance. To set this function correctly, select the cool or dry mode as described above. Press the  button. The appliance operates in the previously selected mode.

When you choose the sleep function, the brightness of the screen is reduced and fan speed is lowered.

When in Cool mode, the selected temperature will increase by 1° per hour in a 2 hour period. This new temperature will be maintained for the next 6 hours and then the appliance will turn off. The Sleep function can be canceled at any time during operation by pressing the “Sleep”, “Mode” or “Fan Speed” button.

The Sleep function maintains the room at optimum temperature without excessive fluctuations in either temperature or humidity with silent operation. Fan speed is always at Low, while room temperature and humidity vary gradually to ensure your comfort. The Sleep function cannot be set in Fan or Dry modes.

6. **UVC Mode** (Select Models Only) - Press and hold the fan button for 3 second until the “UV Lamp” indicator turns on. To turn the UV function off, press and hold the fan button for another 3 seconds until the indicator turns off. **Should any UV light be exposed, stop use immediately and contact customer service.**
7. **Clean Filter** - To ensure proper maintenance, care, and performance, it is recommended that the filter is cleaned on a weekly basis. Simply remove the filter from the back of the unit by using your thumbs to press down on the filter tabs directly above the filter. Clean the filter with warm, soapy water. Dry thoroughly before replacing the filter. Once the filter is completely dry, place the filter back in the unit. For cleaning the outside of your product, only use mild liquid dish washing detergents and warm water. Be sure the cloth being used is only slightly damp (no oil residue permitted). Disconnect the unit from any power source before you start cleaning.

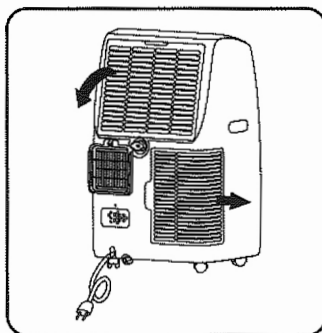

Changing temperature display from/to: Fahrenheit to Celcius

1. Power on the appliance and set to Cool Mode.
2. Press and Hold down both the increase and decrease arrows at the same time for 3 seconds and then release.

Setting the Timer using the control panel or remote control

Programming Start Up -

- Turn on the appliance, choose the mode you want, for example cool, 72°F, high fan speed.
- Turn off the appliance.
- Press the “⏸” button, the screen starts to flash, press the “▽” / “△” to adjust the set time from 0.5-24 hours.
- In 5 seconds without the operation, the timer start function, then the “Timer” symbol lights.
- Press the “⏸” button again to cancel the Timer, and the “Timer” symbol disappear.

Programming Shut Off -

- When the appliance is running, press the “⏸” button, the screen starts to flash.
- Press the “▽” / “△” to adjust the set time from 0.5-24 hours.
- In 5 seconds without the operation, the timer start function, then the “Timer” symbol lights.
- Press the “⏸” button again to cancel the Timer, and the “Timer” symbol disappear.

TIPS FOR CORRECT USE

To get the best performance from your appliance, follow these recommendations:

- Close the windows and doors in the room to be air conditioned (Fig. 1). When installing the appliance semi-permanently, you should leave a door slightly open (as little as 1/2”) to guarantee correct ventilation.
- Protect the room from direct exposure to the sun by partially closing curtains and/or blinds to make the appliance much more economical to run (Fig. 2).
- Never rest objects of any kind on the appliance.
- Do not block the air inlet or outlet of the appliance.
- Reduced air flow will result in poor performance and could damage the unit (Fig. 3).
- Make sure there are no heat sources in the room.
- Never use the appliance in very damp rooms (bathroom for example).
- Never use the appliance outdoors.
- Make sure the appliance is standing on a level surface.

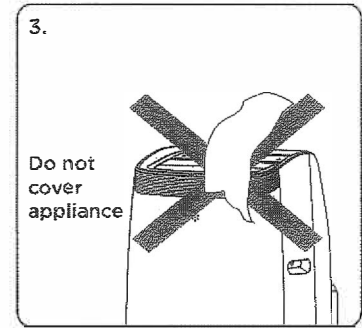
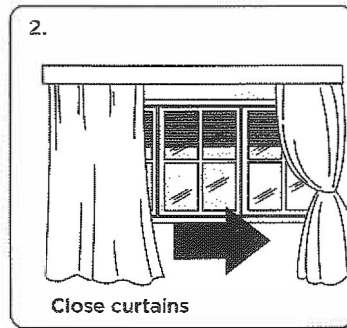
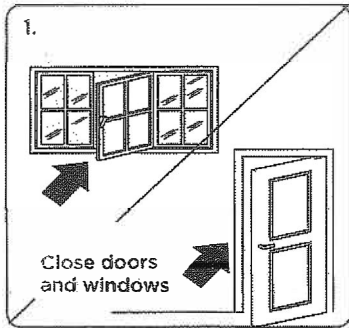

Water drainage method

When there is excess water condensation inside the unit, the appliance stops running and shows "F₁". This indicates that the water condensation needs to be drained using the following procedures:

Manual Draining

1. Power off and unplug the unit from power source.
2. Place a pan (**not included**) under the lower drain plug.
3. Remove the lower drain plug.
4. Water will drain out and collect in the pan (**not included**).
5. After the water is drained, replace the lower drain plug firmly.
6. Turn on the unit.

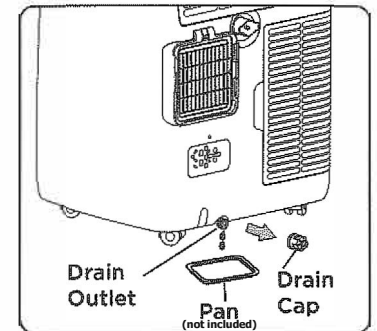

Continuous drainage

When unit is running in Dry mode, you can use the method below for continuous drainage.

1. Power off and unplug the unit from the power source.
2. Remove the drain plug (Fig 1). Be cautious as some residual water may spill during this setup process.
3. Connect a drain hose (Fig. 2). **Note:** Drain hose is only included on select models.
4. The water can be continuously drained through the hose into a floor drain or bucket.
5. Turn on the unit.

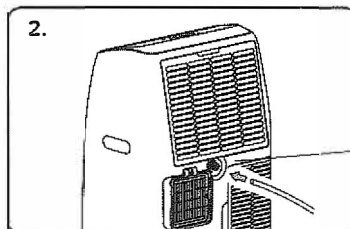
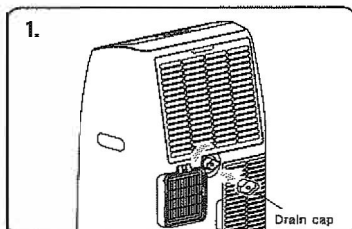

Garden hose or drainage hose

Note: A standard garden hose will work for continuous draining. Garden hose (is not included.)

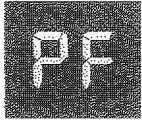
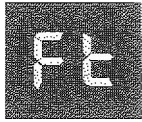
IF DISPLAYED		WHAT SHOULD I DO?
	Probe Failure (sensor malfunction)	If this is displayed, contact a service center.
	Full Tank (condensation reservoir full)	Empty the internal safety tank, following the instructions in the "End of season operations" paragraph.

For Model(s) with UVC

When appliance is running, hold the "❁" button about 3 seconds to activate the UV function, and "UV" symbol will appear.

When appliance is running, hold the "❁" button about 3 seconds to turn off the UV function, and "UV" symbol will disappear.

	UV-C lamp
	Voltage: 12VDC
	Watt: 2W
WARNING	
This appliance contains a UV emitter. Do not stare at the light source.	



Keep Out of Reach of Children
EST NO. : 99940-CHN-1



Warning:

- This appliance contained UV-C Lamp;
- Read the maintenance instructions before operating the appliance;
- Users should not personally clean or maintain the UV-C LED lamp inside the machine.
- If the UV-C LED lamp does encounter an error, please contact a service center, or a certified professional.
- The appliance must be disconnected from the power supply before replacing the UV-C LAMP;
- Before opening doors and access panels bearing the ULTRAVIOLET RADIATION hazard symbol for the conducting USER MAINTENANCE, it is recommended to disconnect the power;
- Do not operate UV-C LAMPS outside of the appliance;
- Unintended use of the appliance or damage to the housing may result in the escape of dangerous UV-C radiation. UV-C radiation may, even in small doses, cause harm to the eyes and skin;
- Appliances that are obviously damaged must not be operated;
- UV-C BARRIERS bearing the ULTRAVIOLET RADIATION hazard symbol should not be removed;

Troubleshooting

Having trouble completing installation? Don't worry, it's usually an easy fix.

PROBLEM	POSSIBLE CAUSES	SOLUTIONS
Air Conditioner will not start	The air conditioner is unplugged	<ul style="list-style-type: none"> • Make sure the air conditioner plug is pushed completely into the outlet
	The fuse is blown/circuit breaker is tripped	<ul style="list-style-type: none"> • Check the house fuse/circuit breaker box and replace the fuse or reset the breaker
	Power Failure	<ul style="list-style-type: none"> • The unit will automatically re-start when power is restored • There is a protective time delay (approx. 3 minutes) to prevent damage to the compressor. For this reason, the unit may not start normal cooling for 3 minutes after it is turned back on.
	The current interrupter device is tripped	<ul style="list-style-type: none"> • Press the RESET button located on the power cord plug • If the RESET button will not stay engaged, discontinue use of the air conditioner and contact a service center.
Air Conditioner does not cool as it should	Airflow is restricted	<ul style="list-style-type: none"> • Change to make sure there are no curtain, blinds, or furniture blocking the air intakes of the air conditioner
	The temperature control may not be set correctly	<ul style="list-style-type: none"> • Lower the set thermostat temperature
	The air filter is dirty	<ul style="list-style-type: none"> • Clean the filter. See the Cleaning and Care Section of the manual
	The room may be too warm	<ul style="list-style-type: none"> • Please allow time for the room to cool down after turning on the air conditioner
	Cold air is escaping	<ul style="list-style-type: none"> • Check for open furnace registers and cold air returns
	The Cooling Coils are frozen	<ul style="list-style-type: none"> • See "Air Conditioner Freezing Up" below
	The air exhaust is detached from the appliance.	<ul style="list-style-type: none"> • Reattach the air exhaust hose to the back of the appliance.
Air Conditioner is freezing up	Ice blocks the air flow and stops the air conditioner from cooling the room	<ul style="list-style-type: none"> • Set the MODE to HIGH FAN or HIGH COOL and set the thermostat to a higher temperature
Remote Control is not working	The batteries are inserted incorrectly	<ul style="list-style-type: none"> • Check the position of the batteries • Replace the batteries
	The batteries may be dead	
Digital display reads "Ft"	The tank is full.	<ul style="list-style-type: none"> • The drain cap must be removed from the rear of the appliance and the tank will need to be drained.



WiFi App Installation (Select Models Only) Must be a compatible WiFi model

Step 1: Download and Install the TCL Home App

Using the camera function on your smartphone, please scan the QR code below to be directed to the TCL Home page. If your phone does not have a QR scanner, download one from the app store or manually type in the URL below in your smartphone's web browser. Then, download and launch the app.



<https://tcl.link/homeplusapp>

Note: The App only supports the 2.4 GHz WiFi band (all routers have a 2.4 GHz band).
Please connect to the 2.4 GHz band before you begin the app setup process.

Step 2: Create an Account

Once you have opened the app, select "Create account." You will then be sent a verification code to your email. Input the code and continue.

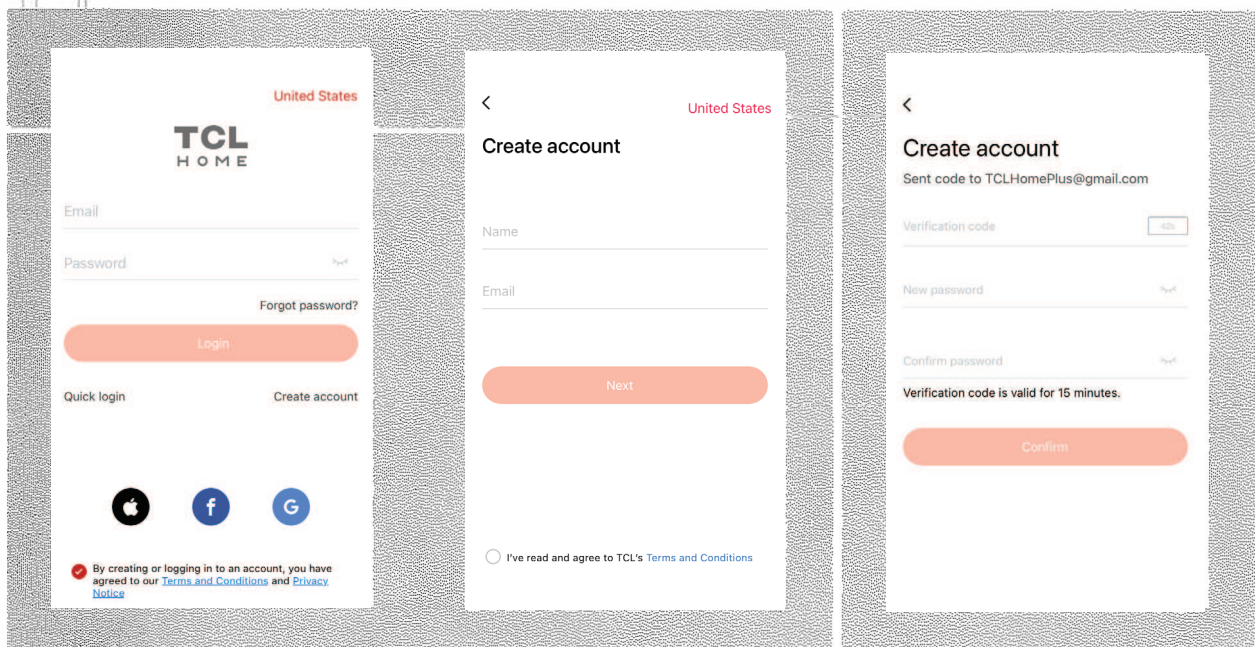

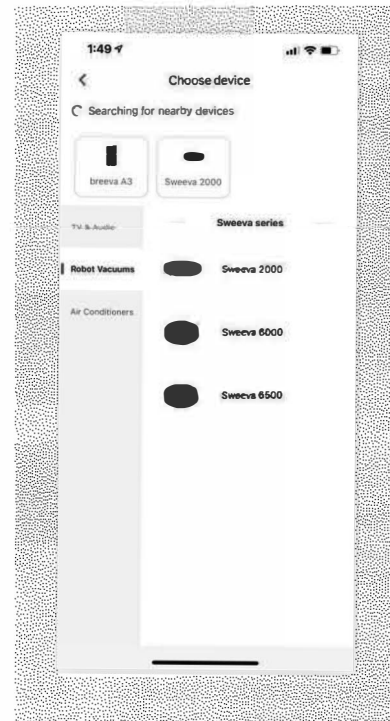
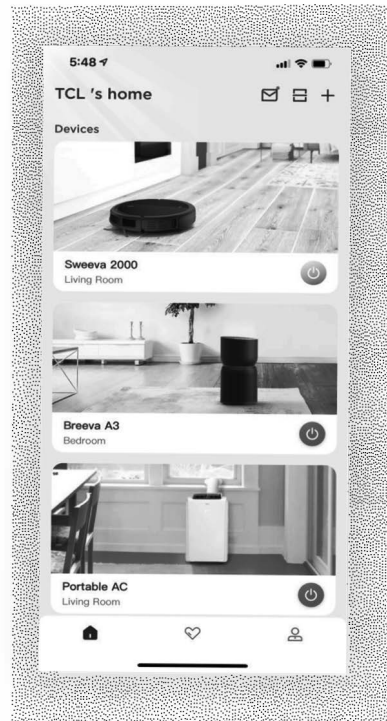

Step 3: Add Your Device

Select the "Add Devices" button and follow the in-app instructions to complete the setup.



ENGLISH

* Only W1OPH95-B have heating function.

Heat Mode - Press the  on the control panel or remote until the Heat mode is lit. Select the target temperature 13°-27°C(55°-81°F) by pressing the  or  button until the corresponding value is displayed. Select the required fan speed by pressing the fan speed button.

Auto-Adjust Smart Mode - The AC will intelligently switch between cool, heat and fan modes depending on the temperature. To start, press  the until smart mode is selected, and the screen resembles the below:



When the appliance is cooling only model, the AC will use Fan mode when the room temperature is below 73°F, and Cool mode if the room temperature is above 73°F.

When the appliance is cooling and heating model, the AC will use Heat mode when room temperature below 68°F, Fan mode when the room temperature is between 68°F and 73°F, and Cool mode if the room temperature is above 73°F.

Sleep Mode- Press the Sleep button on the remote control (there is no sleep mode on the control panel). This function is useful when you are sleeping as it gradually reduces operation of the appliance. To set this function correctly, select cool, heat, dry, or smart mode. Press the  button. The appliance operates in the previously selected mode.

The Sleep function maintains the room at optimum temperature without excessive fluctuations in either temperature or humidity with silent operation. Fan speed is always at Low, while room temperature and humidity vary gradually to ensure your comfort. The Sleep function cannot be set in Fan mode.

Troubleshooting

Having trouble completing installation? Don't worry, it's usually an easy fix.

PROBLEM	POSSIBLE CAUSES	SOLUTIONS
TCL Home App loses connectivity to AC during setup	Wireless router may be too far from AC	• Relocate wireless router closer to AC.
	Network error	• Restart wireless router, AC, and mobile device.
TCL Home App cannot find AC	Network error	• Restart wireless router, AC, and mobile device.
	App & AC are not on the same 2.4GHz channel	• Confirm your device is connected to the 2.4GHz channel.
	Router blocking TCL Home App	• Verify App is not being blocked by the router's firewall.
	Incorrect WiFi Password	• Reinput and verify WiFi password.
Unable to find or connect to Wireless Network	App may need permission to location	• Give TCL Home App permission to Location in phone settings.



Contains FCC ID: 2AC23-WL6U

FCC Caution

This device complies with part 15 of the FCC Rules. Operation is subject to the following two conditions: (1) This device may not cause harmful interference, and (2) this device must accept any interference received, including interference that may cause undesired operation.

Any Changes or modifications not expressly approved by the party responsible for compliance could void the user's authority to operate the equipment.

Note: This equipment has been tested and found to comply with the limits for a Class B digital device, pursuant to part 15 of the FCC Rules. These limits are designed to provide reasonable protection against harmful interference in a residential installation. This equipment generates uses and can radiate radio frequency energy and, if not installed and used in accordance with the instructions, may cause harmful interference to radio communications. However, there is no guarantee that interference will not occur in a particular installation. If this equipment does cause harmful interference to radio or television reception, which can be determined by turning the equipment off and on, the user is encouraged to try to correct the interference by one or more of the following measures:

- Reorient or relocate the receiving antenna.
- Increase the separation between the equipment and receiver.
- Connect the equipment into an outlet on a circuit different from that to which the receiver is connected.
- Consult the dealer or an experienced radio/TV technician for help.
- The distance between user and device should be no less than 20cm.

PRINTED IN MEXICO

SC: 12.06.23 Ebrd:J.M

OBPN:N/A

SHNMDL: W8P95B3_W10PH95B

814100131

