

# Hisense

To download your copy of the complete Owner's Manual:  
<http://consumerservice refurbish.com>

805001354

Click on: Download Owners Manual  
On Manufacturer or Brand, select: HISENSE  
On Product Type, select: TV  
On Model Number, select: 32A4KV / 32A45KV / 40A4KV / 40A45KV / 43A4KV / 43A45KV

Please read this manual carefully before operating your unit and retain for future reference.

## Important Safety Information and Warranty Card

Please read this thoroughly and keep it for future reference.

Fixed Images, such as stock tickers, video game patterns, TV station logos, and websites.

Special Formats that do not use the entire screen. For example, viewing letterbox style (16:9) media on a normal (4:3) display (black bars at top and bottom of screen); or viewing normal style (4:3) media on a widescreen (16:9) display (black bars on left and right sides of screen).

The following symptoms are not signs of malfunction but technical limitation. Therefore we disclaim any responsibility for these symptoms.

LCD Panels are manufactured using an extremely high level of precision technology, however sometimes parts of the screen may be missing picture elements or have luminous spots. This is not a sign of a malfunction.

Do not install the LCD Panel near electronic equipment that produces electromagnetic waves. Some equipment placed too near this unit may cause interference.

Effect on infrared devices - There may be interference while using infrared devices such as infrared cordless headphones.

### End of life directives

Your TV also contains material that can be recycled and reused. For disposal or recycling information, contact your local authorities or the Electronic Industries Alliance at [www.eia.org](http://www.eia.org) (for USA), the Electronic Products Recycling Association at <http://www.epra.com> (for Canada) to find a recycler in your area.

### Non-active pixels

The LCD panel contains almost 3 million thin film transistors, which provide exceptionally sharp video quality. Occasionally, a few non-active pixels may appear on the screen as a fixed black (in the case of a dead pixel), blue, green, or red point. These non-active pixels do not adversely affect the performance of your TV, and are not considered defects.

### Power source

Do not use a different power supply cord to plug the TV into an AC outlet. Using a power cord that did not already come with the TV could cause a fire, electrical shock or damage.

Do not use a power voltage that is different than what Hisense has already specified. This could cause a fire, electrical shock or damage.  
If you do not plan to use this TV for a long time (due to a lengthy trip or some other reason) then be sure to unplug it from the AC outlet.  
Do not plug or unplug the AC cord when your hands are wet. This may cause electrical shock.  
If an outside antenna or cable system is connected with the TV, be sure the antenna or cable system is grounded so as to provide protection against voltage surges and built-up static charges...

No naked flame sources, such as lighted candles, should be placed on the apparatus.

### Attaching a Wall Mount or Stand to the TV

Make sure that your TV has adequate air circulation. Allow enough space around the TV as shown below. Avoid operating the TV at temperatures below 41°F (5°C).

#### WARNINGS:

- When you mount your TV on the wall or place it on furniture, maintain a distance of at least 4 inches between the TV and other objects (walls, cabinet sides, and so on) to ensure proper ventilation. Failing to maintain proper ventilation may cause the TV to overheat.
- Do not use screws that differ from the length and diameter that we have recommended (See the Hisense User Manual or Quick Start Guide).
- Do not fasten the screws too firmly. This may damage the TV or cause it to fall, leading to personal injury. Hisense is not liable for these kinds of accidents.
- Be careful when you touch the TV. Some parts may be warm or hot.
- Do not place any type of fabric or papers underneath, on top of, or beside the TV. This can block ventilation and cause a fire.
- For detailed information about installing the wall mount bracket, see the third-party manufacturer's instructions or contact a professional installer for assistance.

The WiFi Module complies with FCC radiation exposure limits set forth for an uncontrolled environment. This device should be installed and operated with a minimum distance of 20 centimeters between the radiator and your body. (only applicable for Smart TV built-in wireless)

FCC RF Safety Caution Statement  
This equipment complies with FCC RF radiation exposure limits set forth for an uncontrolled environment. This equipment must be installed and operated in accordance with provided instructions and must not be co-located or operating in conjunction with any other antenna or transmitter. End-users and installers must be provided with antenna installation instructions and transmitter operating conditions for satisfying RF exposure compliance.

RF Exposure Statement for Canada  
The radiated output power of the Wireless Device is below the Industry Canada (IC) radio frequency exposure limits. The Wireless Device should be used in such a manner such that the potential for human contact during normal operation is minimized.

(only applicable for TV with RF port)

#### WARNING: Stability Hazard

Never place a television set in an unstable location. A television set may fall, causing serious personal injury or death. Many injuries, particularly to children, can be avoided by taking simple precautions such as:

- ALWAYS use cabinets or stands or mounting methods recommended by the manufacturer of the television set.
- ALWAYS use furniture that can safely support the television set.
- ALWAYS ensure the television set is not overhanging the edge of the supporting furniture.
- ALWAYS educate children about the dangers of climbing on furniture to reach the television set or its controls.
- ALWAYS route cords and cables connected to your television so they cannot be tripped over, pulled or grabbed.
- NEVER place a television set in an unstable location.
- NEVER place the television set on tall furniture (for example, cupboards or bookcases) without anchoring both the furniture and the television set to a suitable support.
- NEVER place the television set on cloth or other materials that may be located between the television set and supporting furniture.
- NEVER place items that might tempt children to climb, such as toys and remote controls, on the top of the television or furniture on which the television is placed.

If the existing television set is going to be retained and relocated, the same considerations as above should be applied.



Buy and install low-cost anchoring devices to prevent TVs, dressers, bookcases or other furniture from tipping.

- Do not operate or handle the TV with wet hands.
- Never place a television set in an unstable location. A television set may fall, causing serious personal injury or death. Many injuries, particularly to children, can be avoided by taking simple precautions such as:
  - Using cabinets or stands recommended by the manufacturer of the television set.
  - Only using furniture that can safely support the television set.
  - Ensuring the television set is not overhanging the edge of the supporting furniture.
  - Not placing the television set on tall furniture (for example, cupboards or bookcases) without anchoring both the furniture and the television set to a suitable support.
  - Not placing the television set on cloth or other materials that may be located between the television set and supporting furniture.
  - Educating children about the dangers of climbing on furniture to reach the television set or its controls.
- If your existing television set is being retained and relocated, the same considerations as above should be applied.

#### Correct way to attach a TV stand

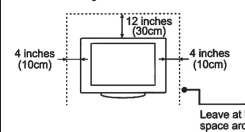

#### Correct way to attach on the wall

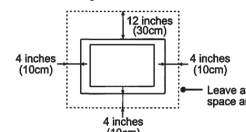

#### Incorrect way to attach the Wall Mount bracket or Stand to the TV

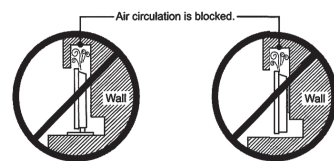

## Disclaimer

Disclaimer: Subscriptions or other payments may be required to access content through some applications. Some or all of the included or downloaded application services in this Hisense device may not function depending on the Internet connection, local limitations of included applications or other reasons outside of Hisense's control. HISENSE EXPRESSLY DISCLAIMS RESPONSIBILITY FOR ANY APPLICATION SERVICE FROM FUNCTIONING AT ANY TIME, FOR CONTENT IN ANY APPLICATION SERVICE, FOR DISRUPTIONS OF SERVICE, LOCAL OR REGIONAL LIMITATIONS, WARRANTIES OF TITLE, NO INFRINGEMENT, AND FOR IMPLIED WARRANTIES OF MERCHANTABILITY OR FITNESS FOR A PARTICULAR PURPOSE. By purchasing this device, you accept such Disclaimer without any claim on Hisense at any time.

## Find what you want

This TV is equipped with this quick setup guide and embedded E-Manual (Ⓢ) > Ⓢ Settings > Support > E-Manual).

### E-Manual support functions

- Search**: Find the help you are looking for.
- Try Now**: Go directly to the function page and try it.
- QR Code**: Scan to open the E-Manual on your mobile device.

### This Quick Setup Guide supports the following models:

32A4KV / 32A45KV / 40A4KV / 40A45KV / 43A4KV / 43A45KV

## What's in the box

Your Hisense TV comes with the following items:

- TV
- remote control
- 2 base stands
- screws (batteries not included)

Disclaimer: This Quick Setup Guide is intended as a general guideline to help you set up your TV. Images throughout this document are for illustrative purposes only and may differ from the actual product.

Accessory type and quantity may vary depending on the model.

## Getting started

### Step 1. Attach stand or mount

Before you start using your TV, attach your TV stand or mount it on the wall.

#### CAUTION:

- Disconnect the A/C power cord before installing a stand or a wall mount bracket.
- The LED display on your TV is fragile. Make sure the TV screen is not scratched or damaged by hard objects or from pressure.
- After the installation is complete, make sure the TV is steady on a table or firmly attached to a wall mount, before removing all protective film, if any.

### Attach the TV stand

To attach the TV stand legs to your TV:

- Carefully place your TV face down on a clean, soft and flat surface.
- Insert the TV base stands into the bottom slots on your TV.
- Use the screws provided to secure each leg tightly.

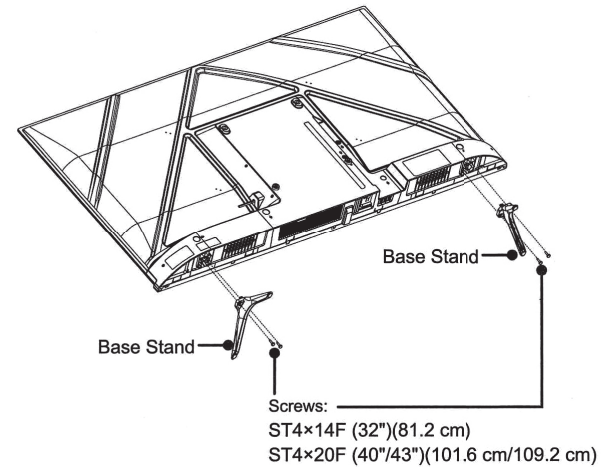

### Attach the wall mount bracket (not included)

Before you begin the third-party manufacturer instructions, be sure to do the following things:

- Place the TV face down on a clean, safe and cushioned surface.
- Remove the TV stand if you have already attached it.
- Place spacers (not included) in the corresponding bracket holes.

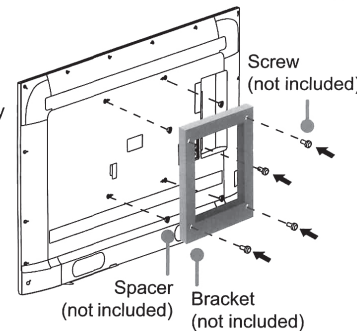

#### CAUTION:

- Follow instructions provided with the wall mount bracket. If it is not correctly mounted, the TV may fall and cause property damage or personal injury.
- When you attach the mount, be sure to use spacers (provided by the third-party manufacturer) between the TV and the bracket.
- To prevent internal damage to the TV and to ensure it is mounted securely, be sure to use fixing screws (not included) that are 8.0 - 10.0 mm in length when measured from the attaching surface of the rear cover.

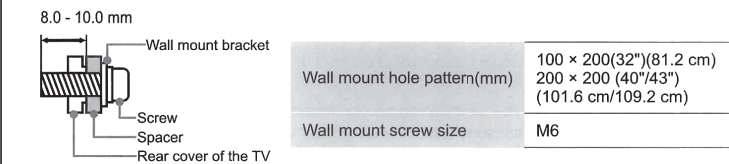

- We do not recommend hanging the TV on a slanted wall, and when wall mounting make sure your television remains parallel to the wall and does not lean forward.

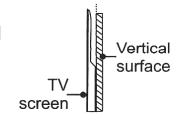

#### NOTE:

- If installed on a ceiling or slanted wall, or the television installed is not parallel to the wall, the television may fall and result in property damage or severe personal injury.
- If you have additional questions, please contact the wall mount manufacturer or the retailer from which you purchased the TV.
- The diameter and length of the screws differ depending on the wall mount bracket model.

The cables mentioned in this guide is not supplied with your unit.

### Step 2. Connect devices to your TV

Check to ensure that you have connected right cables for right ports securely. Loose connections can affect the quality of the picture image and color.

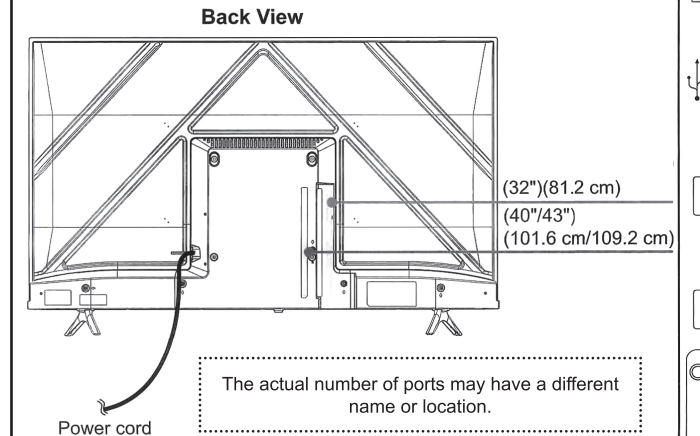

- DIGITAL AUDIO OUT:** Connect an optical cable from an external digital audio system.
- USB:** Connect a USB device for browsing photos, music and movies. Hard disks with a total current consumption or impulse current consumption greater than 500mA are not supported.
- HDMI:** Connect a High Definition Multimedia Interface (HDMI) cable from an external device.
- AV IN:** Connect a composite video cable and left-right audio cables from an external AV device.
- RESET:** Power off / restart (quick press) Reset your TV back to the factory setting (long press for 5 seconds)
- HEADPHONE:** Connect headphones to hear audio from the TV. Headphones with microphones are not supported.
- ANT/CABLE:** Connect an outdoor VHF/UHF antenna.

### Step 3. Get your remote ready

The following table shows the buttons on your remote control and describes what they are for.

BUTTON	DESCRIPTION
Power	Power on/off
INPUT	Change TV input source
App	Quick access buttons to apps
Media	Media content control function buttons
Menu	The button for the Menu
Special	Special function buttons
D-pad	D-pad (up/down/left/right navigation buttons)
OK	Confirmation button
Return	Return to the previous place in the menu or app
EXIT	Exit the menu or app
VOL	Volume (up/down)
CH	Channel (up/down)
Home	Display the Home screen
SLEEP	Adjust sleep timer setting
LIVE TV	Enter Live TV source
Mute	Mute and restore sound
MTS	Set the audio language (MTS)
Number	Enter Channels/input numbers
Sub	Select a digital sub-channel
CC	Turn Closed Caption On/Off and turn Closed Caption on when mute

#### NOTE:

- Buttons listed here are for reference only. Actual remote control may vary depending on model, country.

The remote control vary depend of model: The buttons on the remote control may have a different name or location than the remote control shows in this manual.



### Insert the batteries (Batteries Not Included)

1. Take off the back cover to open the battery compartment of the remote control.
2. Insert two AAA or AA size batteries. Make sure to match the (+) and (-) ends of the batteries with the (+) and (-) ends indicated in the battery compartment.
3. Restore the battery compartment cover.

### Important Information about the remote and batteries

- Discard batteries in a designated disposal area. Do not throw them into a fire.
- Remove old batteries immediately to prevent them from leaking into the battery compartment.
- If you do not intend to use the remote control for a long time, then remove the batteries.
- Battery chemicals can cause a rash. If the batteries leak, clean the battery compartment with a cloth. If chemicals touch your skin then wash it immediately.
- Do not mix old and new batteries.
- Do not mix alkaline, standard (carbon-zinc) or rechargeable (NiCd, NiMH, etc.) batteries.
- Do not continue using the remote if it gets warm or hot.

### Remote Control Range Information

- The remote control can work at a distance of up to 26 feet (792.5 cm) in front of the TV set.
- It can work at a 30 degree horizontal or vertical angle.

### Step 4. Power on the TV

Plug the power cord into a power outlet.

Your TV will display a launch screen showing the Hisense logo.

### Step 5. Complete the first-time setup

The first time you turn on your TV, there is a guided setup to make it easy to connect your TV to the Internet and complete the setup of your TV.

### Step 6. Establish a network connection

1. Press the [ Home ] button on the remote control, and select the  icon to enter into the Settings menu.
2. Select **Network > Network Configuration**.

### Establish a wireless network connection

The TV can directly receive network signals via wireless router. Before you establish a wireless network connection, turn on your Wi-Fi.

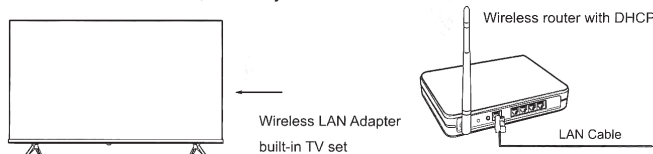

### And setup is done, congratulations!

Now that you've completed the first-time setup, enjoy your TV!

### Text-to-Speech (TTS) and Video Description functionalities on TV

Text-to-Speech (TTS) and Video Description can help you to navigate the menus on the screen and hear an audio description of relevant programs.

Text-to-Speech can convert written text into voice text to help visually impaired people listen to the information they are unable to read. In addition, the Video Description has an audio narration added to certain programs that will describe the main visual elements which visually impaired users may not be able to see.

Follow the steps below to enable the functions:

1. Press the menu button on your remote to access the Menu.
2. Next, select **Settings** to enter the Settings Menu.
3. Select **Accessibility > Narration** or **Voice Guide** to turn the Narration or Voice Guide 'On' or 'Off'.

When **Voice Guide** is turned On, then the contents of each menu displayed can be broadcasted out.

When **Narration** is turned On, then you can hear the introduction of relevant programs.

## Troubleshooting

If you are having trouble with your TV, first try turning it off and on again. If this does not fix the problem, check the tips in the following table.

Issues	Possible solutions
No sound or picture	<ul style="list-style-type: none"><li>• Check if the power cord is plugged into a powered AC outlet.</li><li>• Press the Power button on the remote control to activate the unit from 'Standby' mode.</li><li>• Check to see if the LED light is on or not. If it is, then the TV is receiving power.</li></ul>
I have connected an external source to my TV and I get no picture and/or sound.	<ul style="list-style-type: none"><li>• Check for the correct output connection on the external source and for the correct input connection on the TV.</li><li>• Make sure you have made the correct selection for the input mode for the incoming signal.</li></ul>
When I turn on my TV, there is a delay for a few seconds before the picture appears. Is this normal?	<ul style="list-style-type: none"><li>• Yes, this is normal. The TV is initializing and searching for previous setting information.</li></ul>
The picture is normal but there is no sound	<ul style="list-style-type: none"><li>• Check the volume settings.</li><li>• Check if 'Mute' mode is set to On.</li></ul>
Sound but no picture or black and white picture	<ul style="list-style-type: none"><li>• If the picture is black and white, unplug the TV from the AC outlet and replug it after 60 seconds.</li><li>• Check that the Color is set to 50 or higher.</li><li>• Try different TV channels.</li></ul>
The sound and/or picture is distorted or appears wavy	<ul style="list-style-type: none"><li>• An electric appliance may be affecting the TV. Turn off any appliances that are nearby and move it farther away from the TV.</li><li>• Insert the power plug of the TV set into another power outlet.</li></ul>
The sound and picture is blurry or cuts out	<ul style="list-style-type: none"><li>• If using an external antenna, check the direction, position and connection of the antenna.</li><li>• Adjust the direction of your antenna or reset or fine tune the channel.</li></ul>
A horizontal or vertical stripe appears on the picture and/or the picture is shaking	<ul style="list-style-type: none"><li>• Check if there is an appliance or electric tool nearby that is causing interference.</li></ul>
The plastic cabinet makes a "clicking" type of sound	<ul style="list-style-type: none"><li>• The 'click' sound can occur when the temperature of the television changes. This change causes the television cabinet to expand or contract, which makes the sound. This is normal and the TV is OK.</li></ul>
The remote control does not work	<ul style="list-style-type: none"><li>• Confirm that TV still has power and is operational.</li><li>• Change the batteries in the remote control.</li><li>• Check if the batteries are correctly installed.</li></ul>

## Product Specifications

Model Name	32A4KV / 32A45KV	40A4KV / 40A45KV
Dimension (W x H x D)	Without Stand 28.6 x 16.9 x 3.3 inches (726 x 430 x 84 mm)	35.4 x 20.3 x 3.3 inches (900 x 515 x 85 mm)
	With Stand 28.6 x 18.6 x 6.3 inches (726 x 472 x 159 mm)	35.4 x 22.2 x 7.2 inches (900 x 565 x 182 mm)
Weight	Without Stand 8.2 lbs (3.7 kg)	11.9 lbs (5.4 kg)
	With Stand 8.4 lbs (3.8 kg)	12.1 lbs (5.5 kg)
TV Stand Width(W x D)	26.5 x 6.3 inches (672 x 159 mm)	31.8 x 7.2 inches (807 x 182 mm)
Active Screen Size (Diagonal)	31.5 inches(80.0 cm)	39.5 inches(100.3 cm)
Screen Resolution	1 366 x 768	1 920 x 1 080
Audio Power	6 W + 6 W	7 W + 7 W
Power consumption	50 W	60 W
Power Supply	120 V ~ 60 Hz	

Model Name	43A4KV / 43A45KV
Dimension (W x H x D)	Without Stand 38.0 x 22.2 x 3.5 inches (965 x 563 x 88 mm)
	With Stand 38.0 x 24.1 x 7.2 inches (965 x 611 x 182 mm)
Weight	Without Stand 13.4 lbs (6.1 kg)
	With Stand 13.7 lbs (6.2 kg)
TV Stand Width(W x D)	32.0 x 7.2 inches (814 x 182 mm)
Active Screen Size (Diagonal)	42.5 inches(107.9 cm)
Screen Resolution	1 920 x 1 080
Audio Power	7 W + 7 W
Power consumption	75 W
Power Supply	120 V ~ 60 Hz
Connectivity	Built-in Wireless feature (2x2, 2.4GHz)

## Product Specifications

Receiving Channels	VHF: 2 - 13, UHF: 14 - 69, CATV: 1 - 125 Digital Terrestrial Broadcast (8VSB): 2 - 69 Digital cable (64/256 QAM): 1 - 135
Tuner Type	Frequency synthesized
Receiving System	Analog: NTSC Digital: ATSC/QAM
Operating Temperature	41°F - 95°F(5°C - 35°C)
Operating Humidity	20% to 80% non-condensing
Storage Temperature	5°F to 113°F(-15°C to 45°C)
Storage Humidity	10% to 70%, non-condensing

**Disclaimer:** All products, product specifications, and data are subject to change without notice to improve reliability, function, design or otherwise.

## Certification and Compliance

### FCC Notice

This device has been tested and found to comply with the limits for a Class B digital device pursuant to Part 15 of the FCC Rules. These limits are designed to provide reasonable protection against harmful interference in a residential installation. This device generates, uses, and can radiate radio frequency energy and, if not installed and used in accordance with the instructions, may cause harmful interference to radio communications.

However, there is no guarantee that interference will not occur in a particular installation. If this device does cause harmful interference to radio or television reception, which can be determined by turning the device off and on, the user is encouraged to try to correct the interference by one or more of the following measures:

- Reorient or relocate the receiving antenna.
- Increase the separation between the device and receiver.
- Connect the device into an outlet on a circuit different from that to which the receiver is connected.
- Consult the dealer or an experienced radio/TV technician for help.

**NOTE:** The manufacturer is not responsible for any radio or TV interference caused by unauthorized modifications to this equipment. Such modifications could void the user's authority to operate the equipment.

The Wi-Fi Module complies with FCC radiation exposure limits set forth for an uncontrolled environment. This device should be installed and operated with a minimum distance of 20 centimeters between the radiator and your body.

This device complies with Industry Canada's licence-exempt RSSs. Operation is subject to the following two conditions:

- (1) This device may not cause interference; and
- (2) This device must accept any interference, including interference that may cause undesired operation of the device.

### Declaration of Conformity

Trade Name: Hisense

Responsible Party: Hisense USA Corporation

This device complies with Part 15 of the FCC Rules. Operation is subject to the following two conditions: (1) this device may not cause harmful interference, and (2) this device must accept any interference received, including interference that may cause undesired operation.



Manufactured under license from Dolby Laboratories. Dolby, Dolby Audio, and the double-D symbol are trademarks of Dolby Laboratories Licensing Corporation.



For DTS patents, see <http://patents.dts.com>. Manufactured under license from DTS Licensing Limited. DTS, DTS-HD Master Audio, DTS-HD, Virtual:X, and the DTS-HD logo are registered trademarks or trademarks of DTS, Inc. in the United States and other countries. © 2021 DTS, Inc. ALL RIGHTS RESERVED.



The terms HDMI and HDMI High-Definition Multimedia Interface, and the HDMI Logo are trademarks or registered trademarks of HDMI Licensing Administrator, Inc. in the United States and other countries.

"NOTE: Accessories may vary depending on the model.  
The images shown here are for illustrative purposes only and may be subject to change."



### Environmental Protection

This mark indicates that this product should not be disposed together with other domestic garbage, to avoid damage to the environment or human health due to the disposal of uncontrolled waste. Recycle it responsibly for promoting the sustainable reuse of material resources. To return your used device, please use the return systems available in your location or contact the vendor where you purchased your product they could take this product for recycling and protection of the environment.

©2022. All rights reserved. Hisense and the Hisense logo are registered trademarks of Hisense. Other brand and product names are registered trademarks of their respective owners.

THIS PRODUCT IS LICENSED UNDER THE AVC PATENT PORTFOLIO LICENSE FOR THE PERSONAL USE OF A CONSUMER OR OTHER USES IN WHICH IT DOES NOT RECEIVE REMUNERATION TO (i) ENCODE VIDEO IN COMPLIANCE WITH THE AVC STANDARD ("AVC VIDEO") AND/OR (ii) DECODE AVC VIDEO THAT WAS ENCODED BY A CONSUMER ENGAGED IN A PERSONAL ACTIVITY AND/OR WAS OBTAINED FROM A VIDEO PROVIDER LICENSED TO PROVIDE AVC VIDEO. NO LICENSE IS GRANTED OR SHALL BE IMPLIED FOR ANY OTHER USE. ADDITIONAL INFORMATION MAY BE OBTAINED FROM MPEG LA, L.L.C. SEE [HTTP://WWW.MPEGLA.COM](http://www.mpegla.com)



**CAUTION** When unpacking the TV from the box, DO NOT press on or hit the TV screen as you remove it, mount on the wall or at any other time. Pressing on or hitting the screen could cause it to crack or detach from the bezel. This may result in bodily injury and void manufacturer's warranty.



**Always handle the TV with care.  
Do not press on or hit the screen.**

### REFURBISHED PRODUCT LIMITED NINETY DAYS WARRANTY

The **Refurbished Product Service Center** offers the following WARRANTY to the ORIGINAL purchaser of a product which we have refurbished.

This product that has been refurbished is warranted against any electronic or mechanical defects for a period of NINETY DAYS from the date of the original purchase by the consumer. Since this unit was sold as a refurbished item, the warranty does not apply to any cosmetic appearance items such as scratches. Should a defect occur, the **Refurbished Product Service Center** will repair or, at its option, replace defective unit/parts with new or rebuilt materials without charge for either parts or labor. Replacement unit/parts will be warranted for the remaining portion of the original warranty period.

This warranty does not cover installation or damage from accident, misuse, abuse, improper wiring, incorrect voltage, operating the unit against the instructions in the owner's manual or any product which has been opened, altered, or tampered with.

This warranty does not cover costs for removal and or installation of the unit for repair. Under no circumstances shall the service center be liable for any special, incidental or consequential damages or for any other expenses incurred by reason of use or sale of this product. This warranty is in lieu of any other warranties expressed or implied warranty of merchantability of fitness for particular use or otherwise.

This warranty gives the consumer specific legal rights and they may also have other rights which vary from State to State. Some States do not follow the exclusion or limitation of incidental or consequential damages, hence the above exclusion and limitations may not apply.

**Refurbished Product Service Center**  
13225 Marquardt Avenue Santa Fe Springs, CA 90670.

### WARRANTY REPAIR INFORMATION

If you need service on your unit and this product requires repair during the 90 days warranty period; please go to [www.ConsumerServiceRefurbish.com](http://www.ConsumerServiceRefurbish.com) or call the **Refurbished Product Service Center** at 562-946-3531 to obtain the required return authorization (RA) number. Pack the unit properly (the original carton is ideal for this purpose) along with a copy of your purchase receipt and a letter describing the problem. Send the unit freight prepaid and insured to:

**Refurbished Product Service Center,**  
**Att: Customer Service Department 13225 Marquardt Avenue Santa Fe Springs, CA 90670**

Your unit will be promptly repaired and returned to you.

We will refuse to accept delivery of the returned unit unless the assigned RA number appears on the outside of the shipping carton.

**Owner's Information**  
(Keep for your permanent records)

NAME: \_\_\_\_\_  
ADDRESS: \_\_\_\_\_  
CITY: \_\_\_\_\_ STATE: \_\_\_\_\_ ZIP CODE: \_\_\_\_\_  
PHONE: \_\_\_\_\_ E-MAIL: \_\_\_\_\_  
MODEL: \_\_\_\_\_ SERIAL NO.: \_\_\_\_\_



PRINTED IN MEXICO / SC: 08-23-2023  
OBPN: ES-Y228C01-1 A / TAB  
Elbrd: J.E / SHNMDL: 32A45KV\_B