

# Shark

## Air Purifier

804106961

It's important to read this instructions prior to using your new product for the first time.



### IMPORTANT SAFETY INSTRUCTIONS

HOUSEHOLD USE ONLY

#### ⚠ WARNING

TO REDUCE THE RISK OF FIRE, ELECTRIC SHOCK, OR INJURY:

##### GENERAL WARNINGS

- This appliance has a polarized plug (one blade is wider than the other). To reduce the risk of electric shock, this plug is intended to fit in a polarized outlet only one way. If the plug does not fit fully in the outlet, reverse the plug. If it still does not fit, contact a qualified electrician. **DO NOT** attempt to defeat this safety feature. Unplug or disconnect the appliance from the power supply before servicing.
- DO NOT** operate any fan with a damaged cord or plug.
- DO NOT** run cord under carpeting. **DO NOT** cover cord with throw rugs, runners, or similar coverings. **DO NOT** route cord under furniture or appliances. Keep cord away from high traffic areas and place cord where it will not be tripped over.
- If the power cord is damaged, it must be replaced by the manufacturer, its service agent, or similarly qualified persons in order to avoid a hazard.
- This appliance is not intended for use by anyone (including children) with reduced physical, sensory or mental capabilities, or lack of experience and knowledge, unless they have been given supervision or instruction concerning use of the appliance by a person responsible for their safety.

##### USE WARNINGS

- Children should be supervised to ensure that they **DO NOT** play with the appliance.
- Cleaning and user maintenance shall not be made by children without supervision.
- Prior to cleaning or other maintenance, the appliance must be unplugged from the electrical outlet.
- DO NOT** handle plug or appliance with wet hands.
- DO NOT** use without filter in place.
- Only use Shark® branded filters and accessories.
- DO NOT** damage the power cord:
  - DO NOT** pull or carry appliance by the cord or use the cord as a handle.
  - DO NOT** unplug by pulling on cord. Grasp the plug, not the cord.
  - DO NOT** stand the appliance on the power cord, close a door on the cord, pull the cord around sharp corners, or leave the cord near heated surfaces.

- DO NOT** use with any opening blocked; keep free of dust, lint, hair, or anything that may reduce airflow.
- DO NOT** use if airflow is restricted. If the air paths become blocked, turn the appliance off and unplug from electrical outlet. Remove all obstructions before you plug in and turn on the unit again.
- DO NOT** use if appliance is not working as it should, or has been dropped, damaged, left outdoors, or dropped into water.
- DO NOT** place appliance on unstable surfaces such as chairs or other furniture.
- DO NOT** use in the following areas:
  - Wet or damp surfaces
  - Outdoor areas
  - Spaces that are enclosed and may contain explosive or toxic fumes or vapors (lighter fluid, gasoline, kerosene, paint, paint thinners, mothproofing substances, or flammable dust)
- Turn off all controls before unplugging the appliance.
- Unplug from electrical outlet when not in use and before any maintenance or cleaning.
- Hand wash with soapy water only. Washing with cleaning chemicals could damage the unit.
- Make sure filter is in place after routine maintenance.
- Not suitable for use with solid-state speed controls.

##### REMOTE BATTERY

- Dispose of coin cell batteries according to local regulations. Keep batteries away from children at all times. Even used batteries can cause injury.

**⚠ WARNING: Chemical Burn Hazard. Keep batteries away from children.**

This product contains a lithium button/coin cell battery. If a new or used lithium button/coin cell battery is swallowed or enters the body, it can cause severe internal burns and can lead to death in as little as 2 hours. After changing batteries, always completely close and secure the battery compartment. If the battery compartment does not close securely, stop using the product, remove the battery, and keep it away from children. If you think battery might have been swallowed or placed inside any part of the body, seek immediate medical attention.



1. First, carefully flip the air purifier upside down and place it on a level surface. Twist the filter door to unlock the filter.



2. Take the filter out of its packaging, then insert it back into the unit. **DO NOT** run the air purifier unless the filter is removed from its packaging and properly reinstalled.

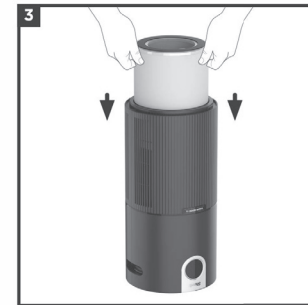

3. With the filter reinstalled, twist the filter door until it clicks into place.

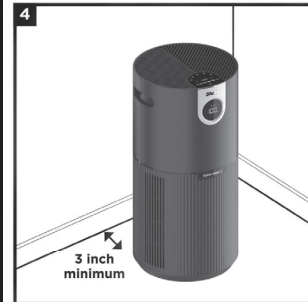

4. Set up the unit on a level floor surface, at least 3 inches (8 cm) away from walls and objects.

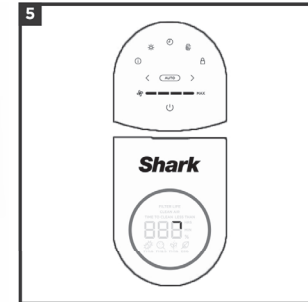

5. Plug the unit into an electrical outlet and press the power button on the top control panel.

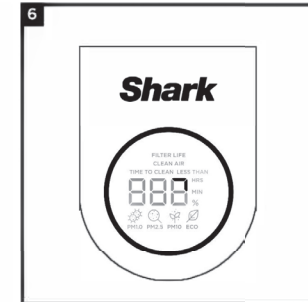

6. When the unit is powered on, it will begin to analyze the air quality indicated by the rotating lights. After a few seconds the unit will display the current air quality.

### CONTROL PANEL

A control panel on the top of the unit and a display screen on the front of the unit.

#### TOP CONTROL PANEL

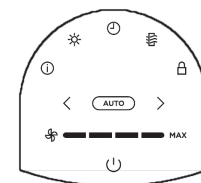

#### FRONT DISPLAY SCREEN

Displays the current air quality status based on the Air Info mode selected on the top control panel.



#### TOP CONTROL PANEL BUTTONS

- On/Off:** Press to turn the power on or off.
- AUTO:** **Auto Mode:** Press to turn on Auto Mode. In this setting the fan speed automatically adjusts based on real time air quality readings. As the air quality improves, the fan speed will decrease. If air quality worsens, the fan speed will increase. **Leave your unit in Auto Mode for optimal filter life and performance.**
- Fan Speed:** Adjusts the speed of the fan. Select one of 4 settings: 1 Low, 2 Medium, 3 High, 4 Maximum. Note: If fan speed is manually changed, auto mode will be deactivated. For tips on optimal fan setting, see Optimizing Fan Speed section.
- Air Info:** Press to switch between air quality display options. See the Air Info Settings section for more information.
- Brightness:** Adjusts the brightness of both the front display screen and the top control panel. Switch between 3 options: full brightness, partially dim, fully dim.
- Shut-Off Timer:** Set the number of hours for the air purifier to run before it automatically shuts off. Timer can be set between 1-12 hours.
- Filter Life:** Press to show the remaining filter life. Once the filter has 0% remaining, the FILTER LIFE button will flash to indicate the filter needs to be changed. See Installing and Removing the Filter section for more information.
- Child Lock:** Hold for two seconds to lock the top control panel buttons. To unlock, hold for two seconds again.

#### Tips and Tricks:

- Optimize Performance in Eco Mode:** After 100% clean air status is achieved for 10 minutes in Auto Mode, your air purifier will enter Eco Mode. Your unit's filter life will be optimized!
- Control Your Air Purifiers Beeping:** Hold the Air Info and Child Lock buttons at the same time for two seconds.

### AIR INFO SETTINGS

The built-in sensor detects your air quality to give you real-time information. Use the **AIR INFO** button to switch between air quality display options.

INFO	FRONT DISPLAY SCREEN	REAL-TIME READING
% CLEAN AIR		Displays the air quality rating: • Poor: 0%-69% • Fair: 70%-84% • Good: 85%-100% % CLEAN AIR uses particulate matter (PM) Air Quality Standards as determined by the EPA to calculate the air quality rating.
TIME TO CLEAN AIR MIN		Shows the estimated time remaining until your air is clean.
PARTICLE SIZES		<b>The PM (particulate matter) value is the amount of particulate in your air, measured in micrograms (µg) per cubic meter. Your air purifier measures three particle sizes, PM1, PM2.5, and PM10.</b>
PM1		Displays the amount of PM1-sized particles in your air, including viruses and ultra-fine allergens.
PM2.5		Displays the amount of PM2.5-sized particles in your air, including smoke and bacteria.
PM10		Displays the amount of PM10-sized particles in your air, including dust, mold, and pollen.

### UNDERSTANDING YOUR AIR QUALITY

The rings on the front and top displays will change color as your air quality changes, allowing you to easily monitor your air quality even when you are far from the unit.

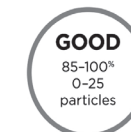

A blue ring means your air quality is good, with a low level of particle concentration.

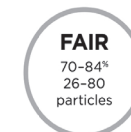

An amber ring means your air quality is fair, with a moderate level of particle concentration. For better results, increase fan speed or select Auto Mode.



A red ring means your air quality is poor, with a high level of particle concentration. For better results, increase fan speed or select Auto Mode.

**Note:** The air quality sensor uses a cumulative particle count across all particle sizes to determine percentage of clean air.

### OPTIMIZING FAN SPEED

Your air purifier is equipped with 4 fan speed settings. Adjust fan speed to optimize your cleaning performance.

DISPLAY	SPEED	BEST FOR
	1	Quiet Operation
	2	Reducing Odors
	3	Reducing Allergens
	4	Maximum Cleaning

### SAVE THESE INSTRUCTIONS

#### SETTING UP YOUR UNIT

##### Parts:

- Air Output Vents
- Control Panel
- Front Display
- Air Purifier Base
- Air Intake Vents
- Filter
- Filter Door

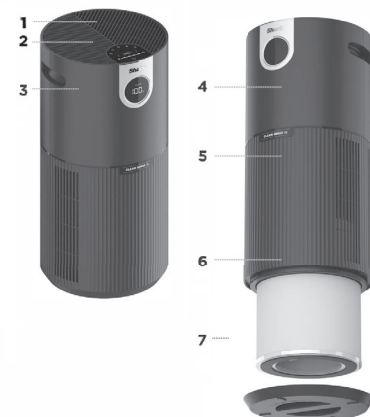

#### TIPS FOR SETTING UP YOUR UNIT

- Make sure the front panel of the unit faces away from the closest wall.
- Do not move the unit while it is running. Turn off the power and unplug the unit before moving it.
- Make sure the vents are not blocked.
- Do not place anything on the air purifier.
- Do not place the air purifier near heaters or radiators.
- Keep the unit out of direct sunlight and away from water or other liquid.
- Keep all nearby doors and windows closed when operating the air purifier.
- Avoid using in very humid environments.

The image shown here is for illustrative purposes only and may be subject to change.

Illustrations may differ from actual product. We are constantly striving to improve our products; therefore the specifications contained herein are subject to change without notice.

**TROUBLESHOOTING AND FREQUENTLY ASKED QUESTIONS**

<b>Product</b>	<b>What are the recommended settings?</b>	We recommend using this air purifier in Auto Mode. Auto Mode leverages your air purifiers particle sensor, and this adjusts the air purifiers fan speed automatically. Higher fan speeds work best for allergy sufferers and dirty environments.
	<b>What is Eco Mode?</b>	After 100% clean air is achieved for 10 minutes in Auto Mode, your air purifier will enter Eco Mode. Your fan will turn off until particles are detected. This will optimize your filters life.
	<b>Can I mute my air purifier beeping?</b>	To control your unit's beeping, hold the Air Info and Child Lock buttons at the same time for two seconds.
	<b>How come my control panel buttons do not work?</b>	Your air purifier may have the child lock setting activated. Press the Child Lock button for two seconds to control this setting.
<b>Air Quality</b>	<b>Why is my air quality always at 100%?</b>	If your air purifier displays a blue ring, your air quality is good. However, air quality will fluctuate as you introduce pollutants into your home. Activities like smoking, cooking, dusting, or spraying cleaning products (among other things) can add more pollutants to your air. Our Clean Sense IQ™ technology tracks this fluctuation in real time and adjusts as it detects particles. You may perform the following to verify that the sensor is working as it should. Spray perfume or aerosol cleaning sprays near the sensor above the filter door. Please contact a service center.
	<b>Why is my air quality never at 100%?</b>	If your air quality never reaches 100%, make sure that the filter is properly installed without its original plastic packaging. Activities like smoking, burning candles, running a humidifier, opening windows, and cooking (among other things) can add more pollutants to your air. Make sure to survey your environment and remove anything that could be causing low air quality.
<b>Filter</b>	<b>Can I wash my filter?</b>	No, the filter is not washable. Keep filter away from water and dispose of it when it is dirty.
	<b>How often should I switch my filter?</b>	We recommend replacing your filter every 6-12 months.
	<b>How do I optimize my filter life?</b>	To maximize your air purifier's filter life, we recommend flipping and rotating the direction of your filter every three months. This will help equalize and balance the distribution of captured particles throughout the filter allowing for extended usage.
	<b>Where can I buy replacement filters?</b>	You can buy replacement filters from select retailers or at: contact a service center.

**INSTALLING AND REMOVING THE FILTER**

**NOTE:** Always remove all protective packaging from the filter before installing.

When the filter timer has 0% remaining, the FILTER LIFE button on the top control panel will blink, indicating that it's time to install a new filter.

- Turn off and unplug the unit before removing or installing filters.
- Carefully flip the air purifier upside down. Remove the bottom filter by twisting to the unlocked position.
- To remove the old filter, pull it out by the removal tabs. Discard old filter in trash.
- Remove all packaging and wrapping from the new filter.
- Insert the new filter, then replace the filter door. Twist the filter door until it clicks into place.
- Carefully, return the air purifier to the upright position. Plug the unit back in and turn on power. Calibration will begin.
- After installing a new filter, press and hold the Filter Life button on the top control panel for 3 seconds to reset the filter life percentage. The unit will beep when the filter life is reset to 100%.

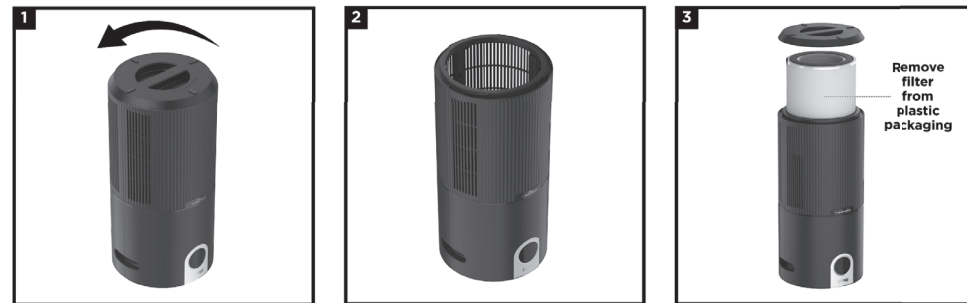

**Disposing of used filters**

Filters can't be cleaned or recycled. After removing a used filter, wrap it in an airtight plastic bag for disposal. As an extra precaution, wear gloves when handling a dirty filter.

The image shown here is for illustrative purposes only and may be subject to change.

Illustrations may differ from actual product.

We are constantly striving to improve our products; therefore the specifications contained herein are subject to change without notice.

**MAINTAINING YOUR AIR PURIFIER**

**NOTE:** Always unplug the unit before doing any cleaning or maintenance.

**Exterior Cleaning:**

For best results, clean the exterior of the unit every two months or as needed. Use a microfiber cloth to remove dust. To sanitize, wipe down the exterior with a microfiber cloth dampened with warm, soapy water. Avoid excess water and abrasive chemical cleaners to prevent damage.

**Interior Cleaning:**

For best results, clean the interior of the unit every two months or as needed. Remove the filter door, take out the filter, and use a vacuum cleaner or a microfiber cloth to remove dust and debris from the interior of the unit. **DO NOT** use abrasive chemical cleaners on the inside of the unit.

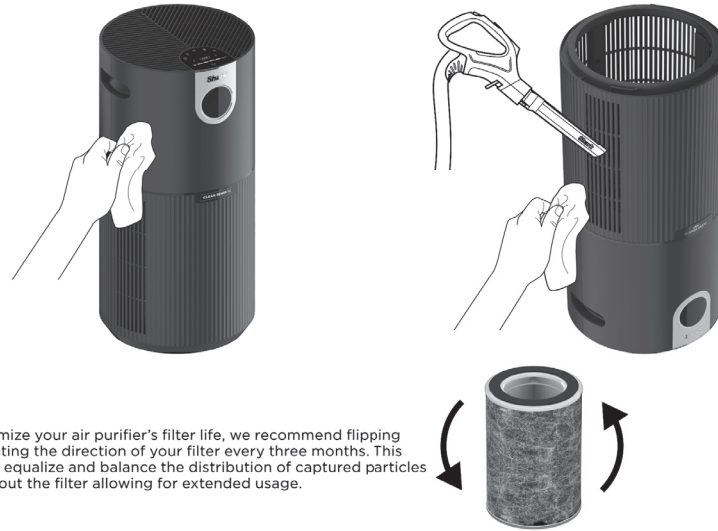

To maximize your air purifier's filter life, we recommend flipping and rotating the direction of your filter every three months. This will help equalize and balance the distribution of captured particles throughout the filter allowing for extended usage.

**IMPORTANT INFORMATION**

**BATTERY REMOVAL AND DISPOSAL**

This product's remote control uses a lithium button battery. When the battery no longer has a charge, it should be removed from the remote and recycled. **DO NOT** incinerate or compost the battery.

When your lithium battery needs to be replaced, dispose of it or recycle it in accordance with local ordinances or regulations. In some areas, it is illegal to place spent lithium batteries in the trash or in a municipal solid waste stream. Return spent battery to an authorized recycling center or to retailer for recycling. Contact your local recycling center for information on where to drop off the spent battery.



**FCC WARNINGS**

Note: This unit has been tested and found to comply with FCC limits for Class B digital devices. These limits are designed to provide reasonable protection against harmful interference in a residential installation. This unit generates, uses, and can radiate radio frequency energy, and if not installed and used in accordance with the instructions, may cause harmful interference to radio communications.

This device complies with part 15 of the FCC Rules. Operation is subject to the following two conditions: (1) this device may not cause harmful interference, and (2) this device must accept any interference received, including interference that may cause undesired operation.

To see if this unit interferes with radio or television reception, try turning it off and on.

To correct any interference:

- Reorient or relocate the receiving antenna.
- Increase the distance between the unit and the receiver.
- Connect the unit to a different outlet than the receiver.
- Consult the dealer or an experienced technician for help.

Caution: Any changes or modifications to this unit not expressly approved by the party responsible for compliance could void the user's authority to operate it.

**TECHNICAL SPECIFICATIONS**

Voltage: 120V~ 60Hz

**REFURBISHED PRODUCT LIMITED NINETY DAYS WARRANTY**

The **Refurbished Product Service Center** offers the following WARRANTY to the ORIGINAL purchaser of a product which we have refurbished.

This product that has been refurbished is warranted against any electronic or mechanical defects for a period of NINETY DAYS from the date of the original purchase by the consumer. Since this unit was sold as a refurbished item, the warranty does not apply to any cosmetic appearance items such as scratches. Should a defect occur, the **Refurbished Product Service Center** will repair or, at its option, replace defective unit/parts with new or rebuilt materials without charge for either parts or labor. Replacement unit/parts will be warranted for the remaining portion of the original warranty period.

This warranty does not cover installation or damage from accident, misuse, abuse, improper wiring, incorrect voltage, operating the unit against the instructions in the owner's manual or any product which has been opened, altered, or tampered with.

This warranty does not cover costs for removal and/or installation of the unit for repair. Under no circumstances shall the service center be liable for any special, incidental or consequential damages or for any other expenses incurred by reason of use or sale of this product. This warranty is in lieu of any other warranties expressed or implied warranty of merchantability of fitness for particular use or otherwise.

This warranty gives the consumer specific legal rights and they may also have other rights which vary from State to State. Some States do not follow the exclusion or limitation of incidental or consequential damages, hence the above exclusion and limitations may not apply.

*Refurbished Product Service Center  
13225 Marquardt Avenue Santa Fe Springs, CA 90670.*

**WARRANTY REPAIR INFORMATION**

If you need service on your unit and this product requires repair during the 90 days warranty period; please go to **www.ConsumerServiceRefurbish.com** or call the **Refurbished Product Service Center** at 562-946-3531 to obtain the required return authorization (RA) number. Pack the unit properly (the original carton is ideal for this purpose) along with a copy of your purchase receipt and a letter describing the problem. Send the unit freight prepaid and insured to:

*Refurbished Product Service Center,  
Att: Customer Service Department 13225 Marquardt Avenue Santa Fe Springs, CA 90670*

Your unit will be promptly repaired and returned to you.

We will refuse to accept delivery of the returned unit unless the assigned RA number appears on the outside of the shipping carton.

**Owner's Information**  
(Keep for your permanent records)

NAME: \_\_\_\_\_

ADDRESS: \_\_\_\_\_

CITY: \_\_\_\_\_ STATE: \_\_\_\_\_ ZIP CODE: \_\_\_\_\_

PHONE: \_\_\_\_\_ E-MAIL: \_\_\_\_\_

MODEL: \_\_\_\_\_ SERIAL NO.: \_\_\_\_\_

8 0 4 1 0 6 9 6 1



PRINTED IN MEXICO  
OBPN:HP200Series\_IB-A4\_MP\_Mv6\_220714  
SC: 03-27-2023  
TAB / Elbrd:J.E.  
SHNMDL: HP202\_B