

Shark Navigator[®] Lift-Away[®] DELUXE

**NV360
NV361**
Series

INSTRUCTIONS

It's important to read this manual prior to using your new product for the first time.



IMPORTANT SAFETY INSTRUCTIONS

FOR HOUSEHOLD USE ONLY • PLEASE READ CAREFULLY BEFORE USE

⚠ WARNING

To reduce the risk of injury, fire, electric shock, and property damage resulting from improper use of the appliance, carefully observe the following instructions. This unit contains electrical connections and moving parts that potentially present risk to the user.

THE MOTORIZED FLOOR NOZZLE, WAND, AND HANDLE CONTAIN ELECTRICAL CONNECTIONS:

- These are not serviceable parts.
 - **DO NOT** use to vacuum any liquids.
 - **DO NOT** immerse in water.
 - If handle/wand is damaged, discontinue use.
- 1 Inspect power cord or plug for any damage before use. **DO NOT** use vacuum cleaner with a damaged cord or plug. Turn off all controls before plugging or unplugging the vacuum cleaner. Store your vacuum cleaner with the power cord secured around the two cord hooks.
 - 2 **DO NOT** use outdoors or on wet surfaces. Use only on dry surfaces.
 - 3 Unplug from electrical outlet when not in use and before servicing.
 - 4 If vacuum cleaner is not working as it should, has been dropped, damaged, left outdoors, or immersed in water, call a Service Center.
 - 5 The hose contains electrical wires. **DO NOT** use when damaged, cut, or punctured.
 - 6 **DO NOT** pull or carry vacuum cleaner by the cord or use the cord as a handle.
 - 7 **DO NOT** unplug by pulling on cord. Grasp the plug, not the cord.
 - 8 **DO NOT** handle plug or vacuum cleaner with wet hands.
 - 9 **DO NOT** run the vacuum cleaner over the power cord, close a door on the cord, or pull cord around sharp corners.
 - 10 The use of an extension cord is **NOT** recommended.
 - 11 **DO NOT** leave vacuum cleaner unattended when plugged in.
 - 12 Keep cord away from heated surfaces.
 - 13 Always turn off the vacuum cleaner before connecting or disconnecting motorized nozzle.

GENERAL USE

- 14 Use only as described in this manual.
- 15 Keep your work area well lit.
- 16 Keep the vacuum cleaner moving over the carpet surface at all times to avoid damaging the carpet fibers.

- 17 **DO NOT** place vacuum cleaner on unstable surfaces such as chairs or tables.

- 18 **DO NOT** put any objects into openings. **DO NOT** use with any opening blocked; keep free of dust, lint, hair, and anything that may reduce airflow.

- 19 **DO NOT** allow young children to operate the appliance or use as a toy. Close supervision is necessary when any appliance is used near children.

- 20 **DO NOT** use without dust cup and/or filters in place.

DUST CUP/FILTERS/ACCESSORIES

Before turning on the vacuum:

- 21 Make sure that all filters are thoroughly dry after routine cleaning.
- 22 Make sure that dust cup and all filters are in place after routine maintenance.
- 23 Make sure accessories are free of blockages.
- 24 Only use filters and accessories provided. Using other brands will void warranty.

HOSE ATTACHMENTS

- 25 **DO NOT** use if airflow is restricted; if the air paths or the motorized floor nozzle become blocked, turn the vacuum cleaner off and unplug from electrical outlet. Remove all obstructions before you turn on the unit again.
- 26 Keep the end of the hose and accessory openings away from face and body.
- 27 Keep cleaning tools and hose suction openings away from hair, face, fingers, uncovered feet, or loose clothing.
- 28 Only use manufacturer's recommended attachments.

GENERAL CLEANING

- 29 **DO NOT** vacuum up large objects.
- 30 **DO NOT** vacuum up hard or sharp objects that could damage the vacuum cleaner such as glass, nails, screws, or coins.
- 31 **DO NOT** vacuum up drywall dust, fireplace ash, or embers. **DO NOT** use as an attachment to power tools for dust collection.

- 32 **DO NOT** vacuum up smoking or burning objects such as hot coals, cigarette butts, or matches.

- 33 **DO NOT** vacuum up flammable or combustible materials (e.g., lighter fluid, gasoline, or kerosene) or use vacuum in areas where they may be present.

- 34 **DO NOT** vacuum up toxic solutions (e.g., chlorine bleach, ammonia, or drain cleaner).

- 35 **DO NOT** use in an enclosed space where vapors are present from paint, paint thinner, moth-proofing substances, flammable dust, or other explosive or toxic materials.

- 36 **DO NOT** vacuum up any liquids.

- 37 **DO NOT** immerse vacuum cleaner in water or other liquids.

- 38 Use extra care when cleaning on stairs.

POLARIZED PLUG

To reduce the risk of electric shock, this vacuum cleaner has a polarized plug (one blade is wider than the other). As a safety feature, this plug will fit into a polarized outlet only one way. If the plug does not fit fully into the outlet, reverse the plug. If it still does not fit, contact a qualified electrician. **DO NOT** force into outlet or try to modify to fit.

TECHNICAL SPECIFICATIONS

Voltage: 120V., 60-Hz
Amps: 10A

SAVE THESE INSTRUCTIONS

GETTING TO KNOW YOUR SHARK NAVIGATOR[®] LIFT-AWAY[®] DELUXE

WELCOME!

Congratulations on your purchase. Use this instruction manual to learn about your new vacuum's great features. From assembly to use to maintenance, you will find it all in here.

- A Handle with Stretch Hose
- B Extension Wand
- C Portable Lift-Away[®] Pod
- D Motorized Floor Nozzle
- E Dusting Brush
- F Crevice Tool
- G Air-Driven Pet Brush
- H Appliance Wand

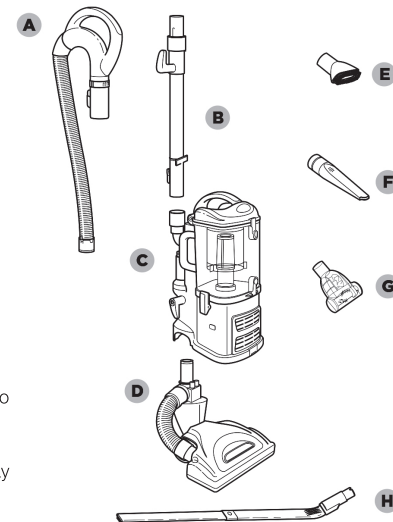

NOTE: Accessories may vary depending on the model. Refer to quick guide, if available.

The images shown here are for illustrative purposes only and may be subject to change.

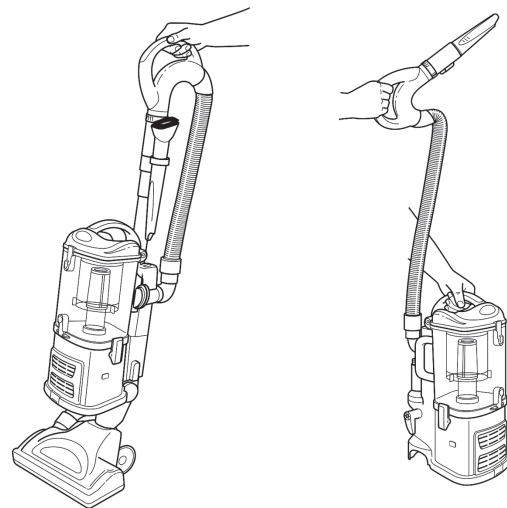

Your new Shark Navigator[®] Lift-Away[®] Deluxe vacuum cleaner can easily be configured into different cleaning modes to meet all your needs: upright vacuum and portable Lift-Away[®] Pod, both with powerful suction.

1 UPRIGHT MODE

Upright vacuuming - floors and carpets.

2 LIFT-AWAY[®] MODE

Take the Lift-Away[®] Pod with you around the house to clean hard-to-reach places.

USING YOUR VACUUM IN UPRIGHT MODE

⚠ WARNING: The ON/OFF switch is located on the top of the Lift-Away[®] Pod. Always ensure the power is set to the OFF (O) position before plugging in or unplugging.

⚠ WARNING: To reduce the risk of electric shock, unplug the unit before assembling, adding or removing attachments, or converting modes.

WHAT DOES THE BRUSHROLL INDICATOR LIGHT MEAN?

Solid Green
The brushroll is on and working as it should.

Solid Red
There is a jam in the brushroll area. Turn your vacuum off and remove the blockage.

Flashing Red[®]
The motorized floor nozzle is overheating. Turn your vacuum off and wait for it to cool down. Next time you are vacuuming that surface, try opening the Suction Control.

No Light
The brushroll is off because the vacuum is in Hard Floor mode.

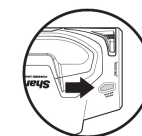

*See Troubleshooting section for further instructions.

STEP 4

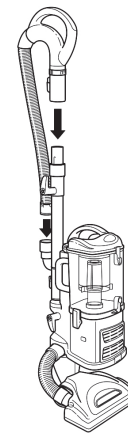

- II Brushroll ON (Carpets & Area Rugs)
- I Suction Only (Bare Floors)
- O OFF

USAGE

- 1 Quickly release the power cord by rotating the upper cord hook located on the back of the wand.
- 2 Press the ON/OFF switch to the Suction Only (I) position to vacuum bare floors or to the (II) position to engage the motorized brushroll for vacuuming carpets and rugs.
- 3 Gently press the floor nozzle down with your foot while you grasp the handle and tilt it back towards you.
NOTE: The brushroll will not spin unless the nozzle is flat against the floor and the handle is tilted back.
- 4 When you are finished vacuuming, turn the vacuum off.

USING YOUR VACUUM IN LIFT-AWAY[®] MODE

NOTE: You can carry your vacuum cleaner in both modes by the carry handle located on top of the dust cup.

SUCTION RELEASE COLLAR

Due to the huge suction power of this vacuum, it may become necessary at times to adjust the suction release collar on the handle. If the vacuum seems difficult to push or pull, if it is lifting up area rugs or when cleaning delicate above-floor surfaces such as drapes, reduce the suction by rotating the collar counterclockwise to open the valve. Rotate the collar clockwise to close the valve when you need high suction and for vacuuming floors and when using the Air-Driven Pet Brush.

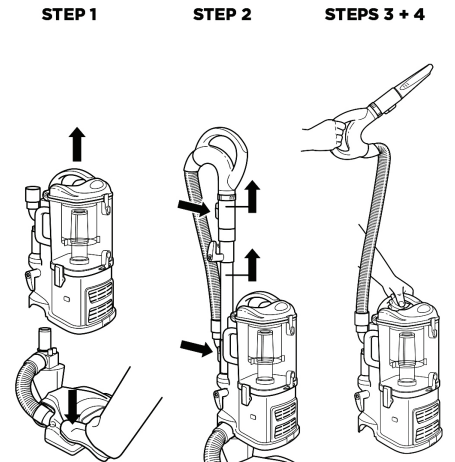

- 1 Separate the portable Lift-Away pod from the floor nozzle by pressing the red release button on the side of the pod. Gently hold the nozzle to the floor with your foot and pull the pod up.
- 2 Press the handle release button and pull the handle up, or press the extension wand release button and pull the extension wand up.
- 3 Attach desired accessory onto the end of either the extension wand or the handle.
- 4 Press the On/Off switch to the "I" position for above-floor cleaning. Hold the handle in one hand while you carry the portable Lift-Away around the house with the other hand.

ABOVE-FLOOR CLEANING

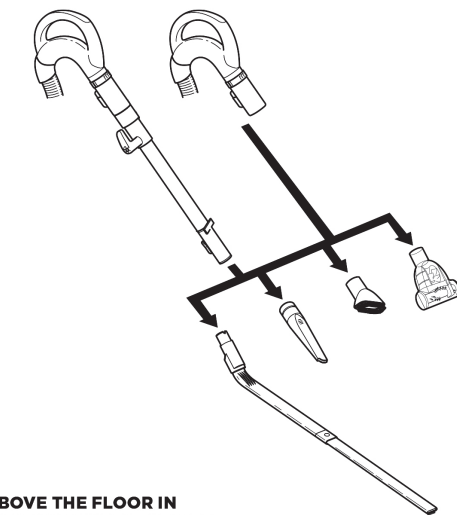

CLEAN ABOVE THE FLOOR IN UPRIGHT VAC OR PORTABLE LIFT-AWAY[®] MODE

- 1 Press the handle release button and pull the handle up, or press the extension wand release button and pull the extension wand up.
- 2 Attach desired accessory onto the end of either the extension wand or the handle.
- 3 Press the On/Off switch to the "I" position for above-floor cleaning.

NOTE: Ensure vacuum is in upright position. **DO NOT** use position "II" when cleaning above the floor in the upright vac mode as this will engage the brushroll. The brushroll may damage your floor if run for a prolonged period of time in one area.

STORAGE AND MAINTENANCE

WARNING: To reduce the risk of shock and unintended operation, turn off power and unplug unit before servicing.

NOTE: DO NOT use soap when cleaning the filters. Hand wash filters only with water to prevent damage from cleaning chemicals. Allow ALL filters to air-dry completely before replacing them in the vacuum to prevent liquid from being drawn into electric parts. **DO NOT** use a hair dryer or other heating methods to dry.

RECOMMENDED CLEANING SCHEDULE:

Dust Cup
Empty after each time you vacuum.

Pre-Motor Filter Kit XFF350 (Foam & Felt)
Clean every 3 months.

Post-Motor Filter XHF350 (HEPA)
Clean every 2 years.

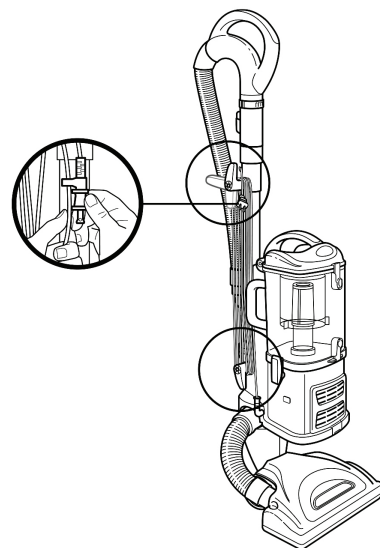

- Convert your vacuum back to upright vac mode.
- Rotate the upper cord hook to its upright position and coil the power cord loosely around the upper and lower cord hooks. Clip the plug onto the cord to secure.
- Store the dusting brush and the crevice tool on the mounts on the accessory holder.
- Store your vacuum cleaner safely in a cool, dry area where it will not be a hazard, will not get damaged, and will not cause damage to anyone or anything.

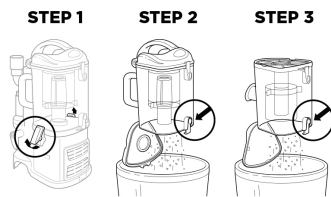

EMPTYING THE DUST CUP

The dust cup needs to be emptied each time you vacuum and periodically during cleaning, when the dust cup appears full.

- Undo the latches on the sides of the dust cup by lifting them up and outwards to remove the dust cup from the motor base.
- Hold the dust cup over a trash receptacle and press the bottom-door release button. Tap gently to empty contents. Press the door shut again until it clicks.
- If needed, turn the dust cup upside down over the trash receptacle and press the top-door release button. Tap gently to remove contents.

Use a dry cloth or paper towel to remove debris stuck to the screen filter inside the dust cup. Press the door shut again until it clicks.

- Replace the dust cup on top of the motor base. Hook the two latches onto the tabs on the sides of the dust cup and push down to lock.

CLEANING THE PRE-MOTOR FILTERS

- Remove the dust cup.
 - Pull the 2 filters out from the top of the motor base.
 - Rinse the filters thoroughly in lukewarm water until the water runs clear.
 - Squeeze out excess water and let air-dry for at least 24 hours before replacing.
 - Place the felt filter in first, then the foam filter.
 - Replace the dust cup.
- NOTE: DO NOT** put the filter in the washing machine or dishwasher.

NOTE: The material in the filter will discolor over time. This is normal, and will not affect the performance of the filter.

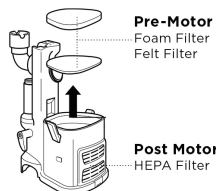

MAINTENANCE - cont'd

WARNING: To reduce the risk of shock and unintended operation, turn off power and unplug unit before servicing.

NOTE: DO NOT use soap when cleaning the filters. Hand wash filters only with water to prevent damage from cleaning chemicals. Allow ALL filters to air-dry completely before replacing them in the vacuum to prevent liquid from being drawn into electric parts. **DO NOT** use a hair dryer or other heating methods to dry.

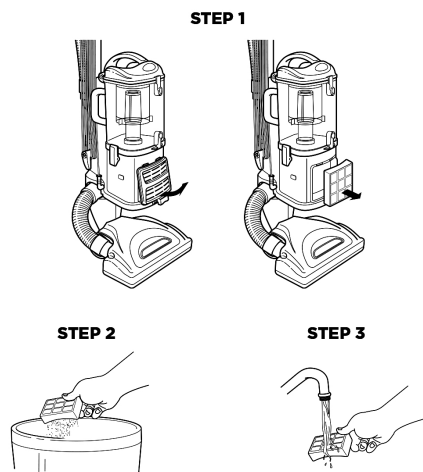

CLEANING THE POST-MOTOR HEPA FILTER

- Remove the filter cover from the front of the vacuum by pulling up on the tab and pulling the cover away from the vacuum. Take out the HEPA filter by pulling it straight out.
- Turn the filter over so that the dirty side is on the bottom and vigorously tap it clean against a garbage can to remove any dust.
- Hold the filter under the tap with the dirty side facing down. Rinse with lukewarm water until the water runs clear. Allow filter to air-dry for 24 hours.
- Once the HEPA filter is dry, replace it back into the vacuum.
- Replace the cover by inserting the two tabs into the holes at the top and then swinging the cover down until it clicks into place.

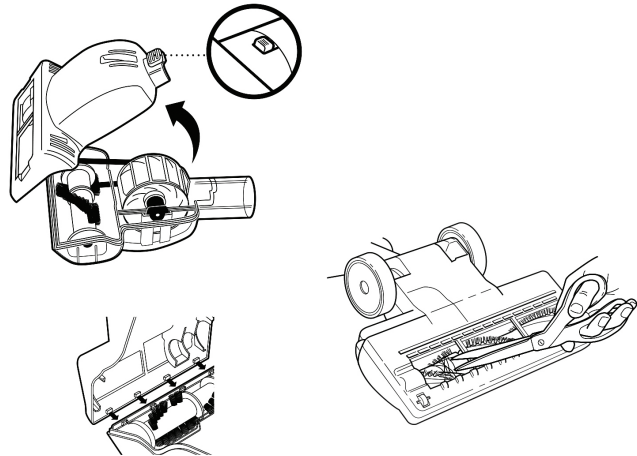

CLEANING THE AIR-DRIVEN PET BRUSH

- Slide the locking latch forward and gently tilt brush housing upward to remove.
- Carefully remove any blockage or debris and use scissors to cut away any buildup of hair or string around the rotating bristle brush.
- To reassemble, insert the tabs on the front edge of the bottom cover into the matching holes in the top half and tilt it back down until it clicks into place.

CLEANING THE MOTORIZED FLOOR NOZZLE

When your motorized floor nozzle needs cleaning or locks onto an object, it automatically shuts down to prevent damage to your lifetime belt. The indicator light will illuminate red, warning you to turn off the vacuum and clear blockage immediately. The light will reset itself once blockage has been cleared and power has been cycled on/off, or vacuum has been locked in the upright position.

- Detach the motorized floor nozzle from the portable Lift-Away® pod.
- Inspect the opening underneath and the brushroll. If a buildup of debris is present, remove it. Use scissors to carefully cut away anything wound around the brushroll.

WARNING: To reduce the risk of shock and unintended operation, turn off power and unplug unit before servicing.

TIP: Make sure you are working in a well-lit area and use a flashlight to help search for blockages.

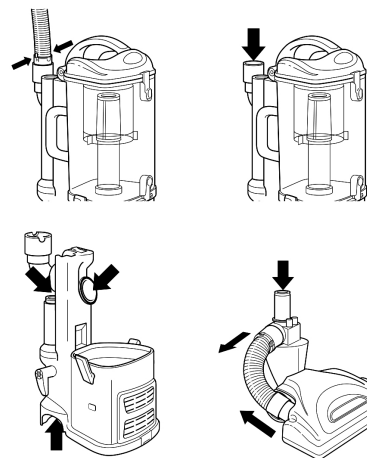

CHECKING FOR BLOCKAGES

Blockages may cause your vacuum to overheat and shut down. To prevent this from happening, check potential blockage areas after heavy use, or if you detect a loss of suction or poor cleaning performance.

- Detach the stretch hose from the back of the portable Lift-Away® pod by squeezing the tabs together and pulling up. Check the hose and pod openings for blockages.
- Remove the dust cup and extension wand and separate the portable Lift-Away pod from the motorized floor nozzle. Check all openings for any blockages.
- Detach the hose on the motorized floor nozzle at the top by squeezing the tabs together and pulling out, and at the bottom by pulling out the connector. Check all openings for any blockages.

TROUBLESHOOTING GUIDE

WARNING: To reduce the risk of shock and unintended operation, turn off power and unplug unit before servicing.

Vacuum is not picking up debris. No suction or light suction. (Refer to Maintenance section for more information.)

- Check filters to see if they need cleaning. Follow instructions for rinsing and drying the filters before reinserting in the vacuum.
- Dust cup may be full; empty dust cup.
- Check hose, hose connections, wand, nozzles, and accessories for blockages; clear blockages if required.
- Remove any string, carpet fibers, or hair that may be wrapped around the brushroll.
- Rotate the suction release collar on the handle clockwise to increase suction power.

Vacuum lifts area rugs.

- Turn off unit to disengage the brushroll. Move switch to position "I" (bare floors) for suction-only cleaning, and turn unit back on.
- Suction is powerful. Take care when vacuuming area rugs or rugs with delicately sewn edges.
- Rotate the suction release collar on the handle counterclockwise to decrease suction power.

Brushroll does not spin.

- If Brushroll Indicator Light on the motorized floor nozzle turns red, the brushroll has stopped spinning. Immediately turn off and unplug vacuum, disconnect the nozzle, and remove blockage before reconnecting and turning vacuum back on.
- With the power on, recline the handle, which will automatically turn on the brushroll.
- Make sure the On/Off switch is set to position "II", Brushroll ON.

Vacuum turns off on its own or indicator light flashes red.

- This vacuum is equipped with a motor-protective thermostat. If your vacuum overheats, the thermostat will automatically turn the suction motor off. Perform the following steps to restart the thermostat:
 - Turn vacuum off and unplug it.
 - Empty dust cup and clean filters (see Maintenance section).
 - Check for blockages in hose, accessories, and inlet openings.
 - Allow unit to cool for a minimum of 45 minutes.
 - Plug in vacuum and turn it on.
- If hose is not fully connected to the pod, it can cause a poor electrical connection and the hose can come loose, turning the vacuum off.
 - Turn vacuum off and unplug it.
 - Empty dust cup and clean filters.
 - Check for blockages in hose, accessories, and inlet openings.
 - Remove cord from cord hook so hose latch can be seen and engaged.
 - Ensure that hose, wand, and handle are all clicked securely into place at all connection points:
 - Where hose meets back of pod (may require additional force; pull on hose to ensure latch is fully engaged)
 - Where wand plugs into floor nozzle
 - Where handle plugs into wand
 - Plug in vacuum and turn it on.

Note: If vacuum still does not start, contact a Service Center.

REFURBISHED PRODUCT LIMITED NINETY DAYS WARRANTY

The **Refurbished Product Service Center** offers the following WARRANTY to the ORIGINAL purchaser of a product which we have refurbished.

This product that has been refurbished is warranted against any electronic or mechanical defects for a period of NINETY DAYS from the date of the original purchase by the consumer. Since this unit was sold as a refurbished item, the warranty does not apply to any cosmetic appearance items such as scratches. Should a defect occur, the **Refurbished Product Service Center** will repair or, at its option, replace defective unit/parts with new or rebuilt materials without charge for either parts or labor. Replacement unit/parts will be warranted for the remaining portion of the original warranty period.

This warranty does not cover installation or damage from accident, misuse, abuse, improper wiring, incorrect voltage, operating the unit against the instructions in the owner's manual or any product which has been opened, altered, or tampered with.

This warranty does not cover costs for removal and or installation of the unit for repair. Under no circumstances shall the service center be liable for any special, incidental or consequential damages or for any other expenses incurred by reason of use or sale of this product. This warranty is in lieu of any other warranties expressed or implied warranty of merchantability of fitness for particular use or otherwise.

This warranty gives the consumer specific legal rights and they may also have other rights which vary from State to State. Some States do not follow the exclusion or limitation of incidental or consequential damages, hence the above exclusion and limitations may not apply.

Refurbished Product Service Center
13225 Marquardt Avenue Santa Fe Springs, CA 90670.

WARRANTY REPAIR INFORMATION

If you need service on your unit and this product requires repair during the 90 days warranty period; please go to www.ConsumerServiceRefurbish.com or call the **Refurbished Product Service Center** at 562-946-3531 to obtain the required return authorization (RA) number. Pack the unit properly (the original carton is ideal for this purpose) along with a copy of your purchase receipt and a letter describing the problem. Send the unit freight prepaid and insured to:

Refurbished Product Service Center,
Att: Customer Service Department 13225 Marquardt Avenue Santa Fe Springs, CA 90670

Your unit will be promptly repaired and returned to you.

We will refuse to accept delivery of the returned unit unless the assigned RA number appears on the outside of the shipping carton.

Owner's Information
(Keep for your permanent records)

NAME: _____

ADDRESS: _____

CITY: _____ STATE: _____ ZIP CODE: _____

PHONE: _____ E-MAIL: _____

MODEL: _____ SERIAL NO.: _____



804108814

PRINTED IN MEXICO
OBPN: NV360_series_IB_E_170831
SC: 05-12-2021_TAB

Elbrd: Y.T_ReDesign
MODEL: NV360_26_BP



Please be sure to read the enclosed Owner's Guide prior to using your unit.

Shark Navigator™ LIFT-AWAY® PRO

804009604A

QUICK START GUIDE

WHAT'S INSIDE

- (A) Handle with Stretch Hose
- (B) Floor Nozzle
- (C) Extension Wand
- (D) Portable Lift-Away® Pod
- (E) Crevice Tool
- (F) Upholstery Tool

ASSEMBLY

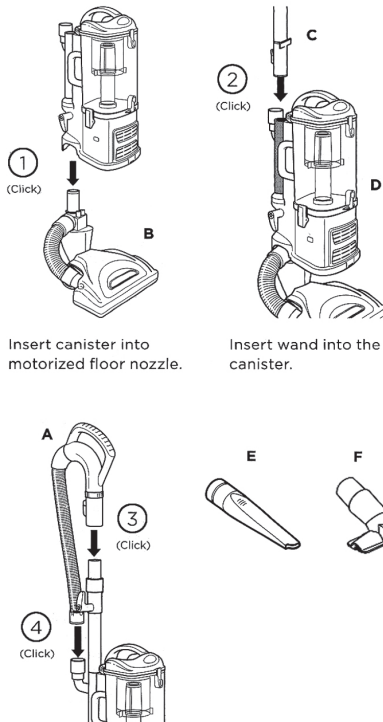

Connect handle to the wand, pressing until it clicks into place. Connect hose to the back of the canister pressing until it clicks into place.

MAINTENANCE

Empty dust cup after each use

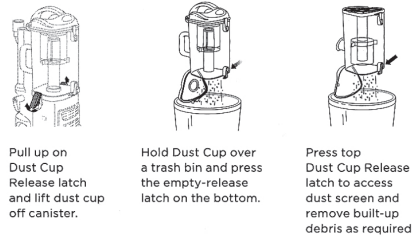

Cleaning Filters

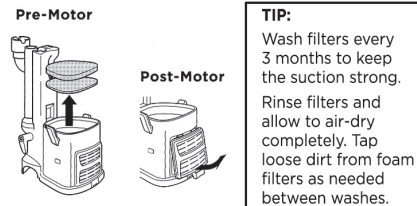

TIP:

Wash filters every 3 months to keep the suction strong. Rinse filters and allow to air-dry completely. Tap loose dirt from foam filters as needed between washes.

Pre-Motor (foam and felt):

With the dust cup removed, take out and rinse the foam and felt filters with water only.

Post-Motor (HEPA):

To access the HEPA filter, reach under the grill and pull the Filter Access latch to remove the grill. Remove and rinse the HEPA filter with water only. Let all filters air-dry completely before reinstalling.

Easy brushroll maintenance

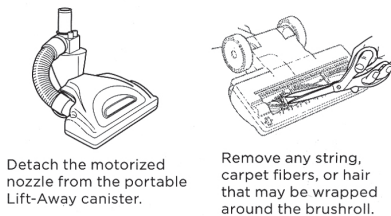

Detach the motorized nozzle from the portable Lift-Away canister.

Remove any string, carpet fibers, or hair that may be wrapped around the brushroll.

VERSATILE FLOOR-TO-CEILING CLEANING

FLOOR CLEANING

- 1 **Plug In Vacuum**
Then place your foot gently on the floor nozzle and tilt the handle back.



- 2 **Choose Setting**
Slide the power switch to the appropriate floor setting and start cleaning.

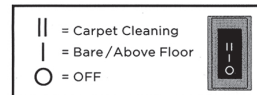

BRUSHROLL ON/OFF:

- 1 Press the ON/OFF switch at the top of the canister to the I position to vacuum bare floors (straight suction only) or use Lift-Away® mode. To vacuum carpets and rugs, set the switch to the II position to engage the motorized brushroll.
- 2 Press the floor nozzle down with your foot and tilt the handle back towards you to engage the brushroll.

PORTABLE LIFT-AWAY® MODE

- 1 **Plug In Vacuum**
Press Lift-Away button to lift canister off floor nozzle. You are now ready to clean those hard-to-reach places.

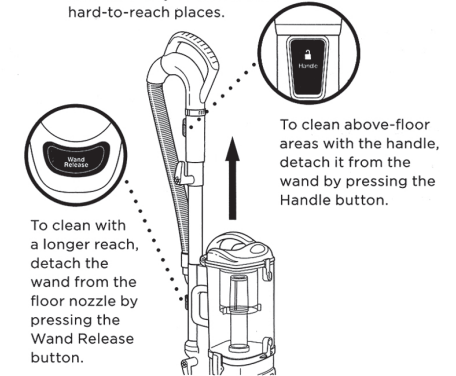

To clean with a longer reach, detach the wand from the floor nozzle by pressing the Wand Release button.

To clean above-floor areas with the handle, detach it from the wand by pressing the Handle button.

- 2 **Attach desired cleaning accessory.**

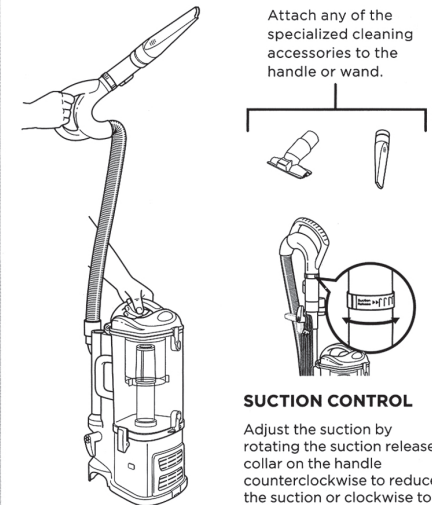

SUCTION CONTROL

Adjust the suction by rotating the suction release collar on the handle counterclockwise to reduce the suction or clockwise to increase suction.

Note: Accessories may vary depending on the model



8 0 4 0 0 9 6 0 4 A

PRINTED IN MEXICO Elbrd: Y.T.
OBPN: NV361PRK_QSG_REV_180813
SC: 09-29-2019_1P MODEL: NV361PRK_BP

Note: The images shown here are for illustrative purpose only and may vary.