

# Shark ROTATOR

804109913

## IMPORTANT SAFETY INSTRUCTIONS FOR HOUSEHOLD USE ONLY

### ⚠ WARNING

To reduce the risk of injury, fire, electric shock, and property damage resulting from improper use of the appliance, carefully observe the following instructions. This unit contains electrical connections and moving parts that potentially present risk to the user.

#### THE POWER NOZZLE, WAND, AND HANDLE CONTAIN ELECTRICAL CONNECTIONS:

- These are not serviceable parts.
- Do not use to vacuum any liquids.
- Do not immerse in water.
- If handle/wand is damaged, discontinue use.

- 1 Inspect power cord and plug for any damage before use. DO NOT use vacuum cleaner with a damaged cord or plug. Turn off all controls before plugging-in or unplugging the vacuum cleaner. Store your vacuum cleaner with the power cord secured around the two cord hooks.
- 2 DO NOT use outdoors or on wet surfaces. Use only on dry surfaces.
- 3 Unplug from electrical outlet when not in use and before servicing.
- 4 If vacuum cleaner is not working as it should, has been dropped, damaged, left outdoors, or dropped into water, return it to SharkNinja Operating LLC for examination, repair, or adjustment.
- 5 DO NOT use if hose is damaged, cut, or punctured.
- 6 DO NOT pull or carry vacuum cleaner by the cord or use the cord as a handle.
- 7 DO NOT unplug by pulling on cord. Grasp the plug, not the cord.
- 8 DO NOT handle plug or vacuum cleaner with wet hands.
- 9 DO NOT run the vacuum cleaner over the power cord, close a door on the cord, or pull cord around sharp corners.
- 10 The use of an extension cord is NOT recommended.
- 11 DO NOT leave vacuum cleaner unattended when plugged in.
- 12 Keep cord away from heated surfaces.
- 13 Always turn off the vacuum cleaner before connecting or disconnecting motorized nozzle.

#### GENERAL USE

- 14 Use only as described in this manual.
- 15 Keep your work area well lit.
- 16 Keep the vacuum cleaner moving over the carpet surface at all times to avoid damaging the carpet fibers.
- 17 DO NOT place vacuum cleaner on unstable surfaces such as chairs or tables.
- 18 DO NOT put any objects into openings. DO NOT use with any opening blocked; keep free of dust, lint, hair, and anything that may reduce airflow.
- 19 DO NOT allow the appliance to be used by children. Close attention is necessary when used near children. This is not a toy.
- 20 DO NOT use without dust cup and/or filters in place.

#### DUST CUP/FILTERS/ACCESSORIES

Before turning on the vacuum:

- 21 Make sure that all filters are thoroughly dry after routine cleaning.
- 22 Make sure that dust cup and all filters are in place after routine maintenance.
- 23 Make sure accessories are free of blockages.

#### HOSE ATTACHMENTS

- 24 Only use Shark-brand filters and accessories (failure to do so will void the warranty).
- 25 DO NOT use if airflow is restricted. If the air paths or the motorized floor nozzle become blocked, turn the vacuum cleaner off and unplug from electrical outlet. Remove all obstructions before you turn on the unit again.
- 26 Keep the end of the hose and accessory openings away from face and body.
- 27 Keep cleaning tools and hose suction openings away from hair, face, fingers, uncovered feet, or loose clothing.

- 28 Only use manufacturer's recommended attachments.

#### GENERAL CLEANING

- 29 DO NOT vacuum up large objects.
- 30 DO NOT vacuum up hard or sharp objects such as glass, nails, screws, or coins that could damage the vacuum cleaner.
- 31 DO NOT use to vacuum up drywall dust, fireplace ash, or embers. DO NOT use as an attachment to power tools for dust collection.
- 32 DO NOT vacuum up smoking or burning objects such as hot coals, cigarette butts, or matches.
- 33 DO NOT vacuum up flammable or combustible materials (e.g., lighter fluid, gasoline, or kerosene) or use vacuum in areas where they may be present.
- 34 DO NOT vacuum up toxic solutions (e.g., chlorine bleach, ammonia, or drain cleaner).
- 35 DO NOT use in an enclosed space where vapors are present from paint, paint thinner, moth-proofing substances, flammable dust, or other explosive or toxic materials.
- 36 DO NOT vacuum up any liquids.
- 37 DO NOT immerse vacuum cleaner in water or other liquids.
- 38 Use extra care when cleaning on stairs.

#### POLARIZED PLUG

To reduce the risk of electric shock, this vacuum cleaner has a polarized plug (one blade is wider than the other). As a safety feature, this plug will fit into a polarized outlet only one way. If the plug does not fit fully into the outlet, reverse the plug. If it still does not fit, contact a qualified electrician. DO NOT force into outlet or try to modify to fit.

## GETTING TO KNOW YOUR SHARK® ROTATOR® LIFT-AWAY® SPEED

### WELCOME!

Congratulations on your purchase. Use this instruction manual to learn about your new vacuum's great features. From assembly to use to maintenance, you will find it all in here.

#### MAIN UNIT

- A Handle Release Button
- B Hose
- C Upper Cord Hook
- D Hose Clip
- E Wand
- F Wand Release Button
- G Brushroll Button
- H Power Button
- I Lift-Away Pod
- J Lift-Away Button
- K Motorized Floor Nozzle
- L Lower Cord Hook
- M Brushroll Indicator Light
- N Headlights

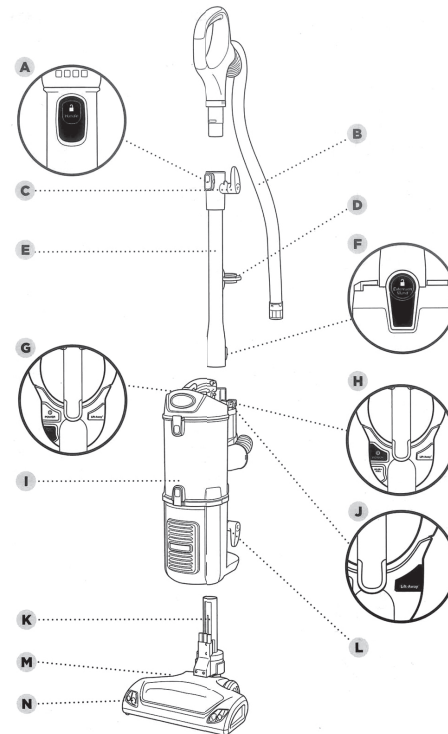

Accessory type and quantity may vary depending on the model.

## ASSEMBLING YOUR VACUUM

**TIP:** For quick cord access, rotate upper hook down and remove cord.

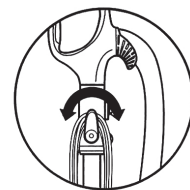

**TIP:** To store your vacuum, wrap cord around cord hooks.

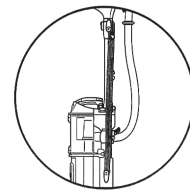

**TIP:** Use cord clip located on the side of wand to hold cord in place while vacuuming.

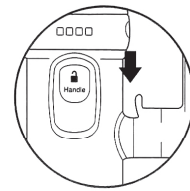

- STEP 1 Place the pod onto floor nozzle.
- STEP 2 Slide wand into base of pod.

### STEP 3

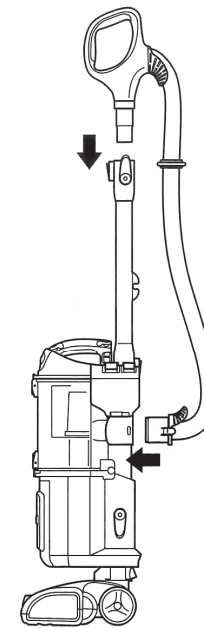

- 3 Insert handle into top of wand. Then insert the hose into the hose connector.

### STEP 4

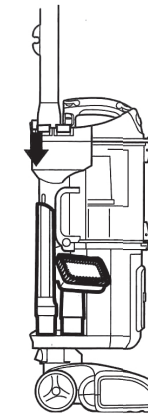

- 4 Insert accessory tools into the accessory holder.

## USING YOUR VACUUM IN UPRIGHT MODE

**⚠ WARNING: DO NOT use to pick up drywall dust, fireplace ash, or embers. DO NOT use as an attachment to power tools for dust collection.**

#### WHAT DOES THE BRUSHROLL INDICATOR LIGHT MEAN?

##### Solid Green

The brushroll is on and working as it should.

##### Solid Red

There is a jam in the brushroll area. Turn your vacuum off and remove the blockage.

##### No Light

The brushroll is off. To turn it on, press the BRUSHROLL button. The light should turn green, and the brushroll should spin.

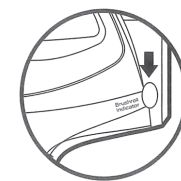

- 1 Plug power cord into outlet. Place foot on floor nozzle and tilt handle back.

#### TECHNICAL SPECIFICATIONS

Voltage: 120V, 60Hz  
Amps: 6A

### STEP 2

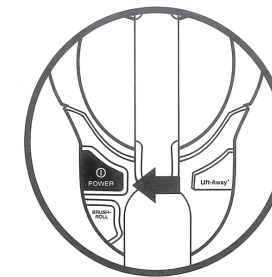

- 2 Press POWER to clean hard floor surfaces, area rugs or above-floor. The brushroll will not spin in this mode.

### STEP 3

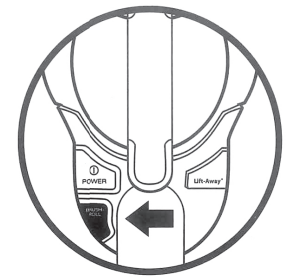

- 3 Press POWER and BRUSHROLL to clean carpets. The BRUSHROLL button will illuminate green. The brushroll will spin only when the vacuum is reclined and the Brushroll Indicator Light is green.

**NOTE:** For deep cleaning per ASTM F 608 (embedded dirt in carpets), please ensure brushroll is on with the suction control closed.

## USING YOUR VACUUM IN ABOVE-FLOOR MODE

#### THE BENEFITS OF SUCTION CONTROL

Suction Control is a way for you to adjust suction power when you are using different tools or vacuuming different surfaces. For example, if you are feeling resistance while vacuuming thick carpet or upholstery, opening the suction control to MIN will help reduce your push/pull effort.

### STEP 1

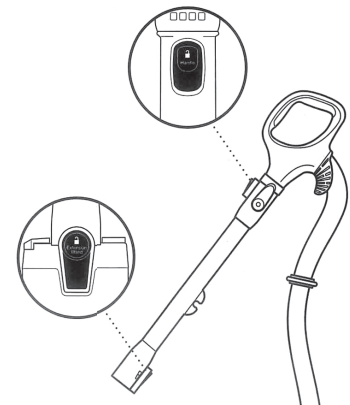

- 1 Press Handle Release button when you need to clean within short reach. OR Press Extension Wand button on pod when you need to clean with a longer reach.

### STEP 2

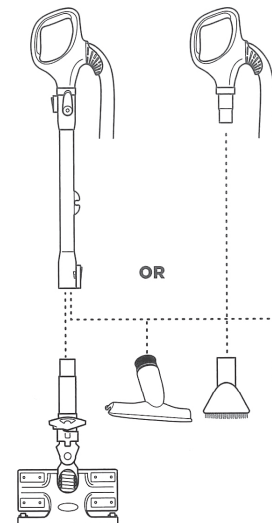

- 2 Attach the desired tool to the wand or handle end.

### STEP 3

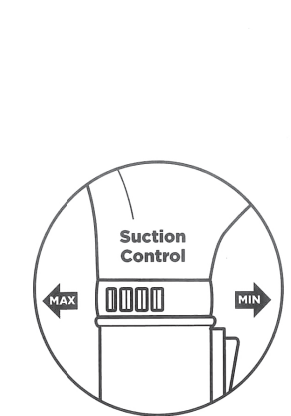

- 3 The collar is located at the base of the top handle. Rotate the collar counterclockwise to minimize suction. Close by rotating clockwise to maximize suction.



## USING YOUR VACUUM IN LIFT-AWAY® MODE

**WARNING:** Ensure solid footing when using in Lift-Away mode. Using using Lift-Away mode when you lack stability may result in personal injury.

**TIP:** Hold pod in hand when cleaning in Lift-Away mode.

### WHAT IS LIFT-AWAY?

Our Lift-Away feature allows you to remove the pod from the floor nozzle to easily clean stairs, above-floor areas with accessories, or hard floors with the hard-floor attachments.

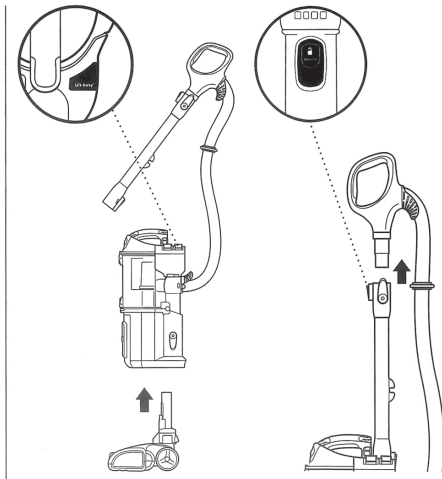

#### LIFT-AWAY CLEANING

- 1 Press LIFT-AWAY to lift pod off floor nozzle.
- 2 Press Handle Release button when you need to clean within short reach.

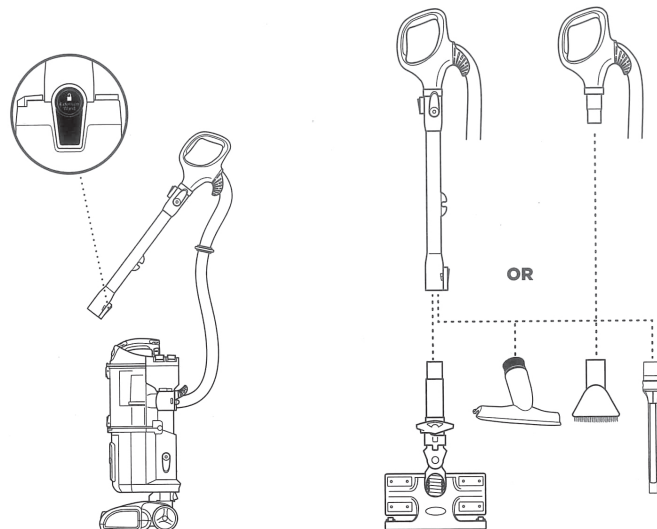

- 3 Or you can press Extension Wand on pod when you need to clean with a longer reach.
- 4 Attach desired cleaning tool to the end of handle or wand.

## MAINTENANCE

To keep your vacuum's suction power optimal, follow these instructions. Make sure unit is off and cord is unplugged.

**WARNING:** To reduce the risk of shock and unintended operation, turn power off and unplug unit before servicing.

Hand wash with water only to prevent damage from cleaning chemicals. Allow ALL filters to dry completely before replacing in the vacuum to prevent liquid from being drawn into electric parts.

**IMPORTANT:** Do not use soap when cleaning the HEPA filter.

#### STEP 1 STEP 2

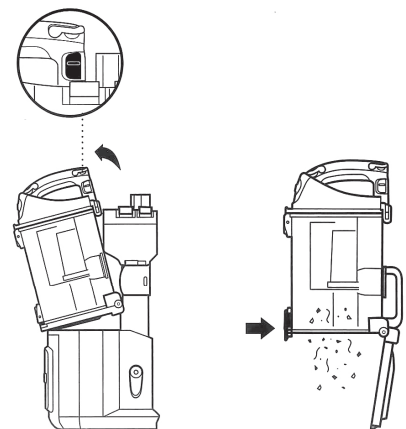

### RECOMMENDED FILTER CLEANING SCHEDULE:

**Pre-Motor Filter Kit**  
(Foam & Felt)  
1229FC340  
Clean every 3 months.

**Post-Motor Filter**  
(HEPA)  
XHF340  
Clean once a year.

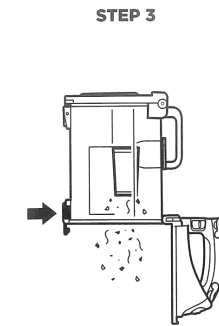

- 3 Press the top dust cup release latch to access the dust screen and remove built-up debris as required.

### EMPTYING THE DUST CUP

- 1 Pull up on dust cup release latches and lift dust cup off pod.
- 2 Hold dust cup over a trash bin and press the bottom dust-cup release latch.

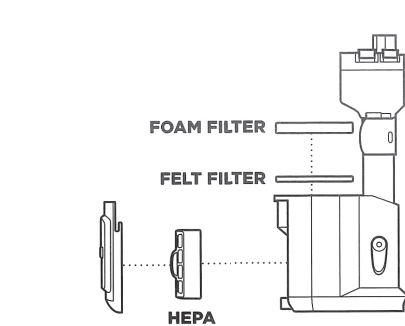

### CLEANING THE FILTERS

- 1 **Pre-Motor (foam and felt):** With the dust cup removed, take out and rinse the foam and felt filters with water. Tap loose dirt off filters between washes as needed.
- 2 **Post-Motor (HEPA):** To access the HEPA filter, reach under the grill, and press the button and pull the grill away from the vacuum. Remove and rinse the HEPA filter.

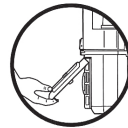

## CHECKING FOR BLOCKAGES

**WARNING:** To reduce the risk of shock and unintended operation, turn power off and unplug unit before servicing.

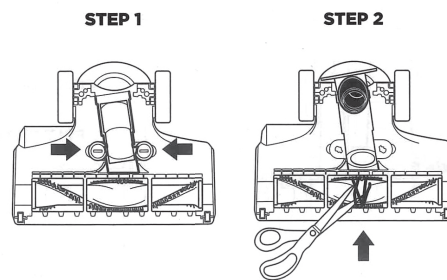

#### BOTTOM OF FLOOR NOZZLE

- 1 Using a coin, turn the locking screws to the unlock position and pull up to expose the airway. Remove the blockage.
- 2 Remove any string, hair or debris that may be wrapped around the brushroll.

#### STEP 1

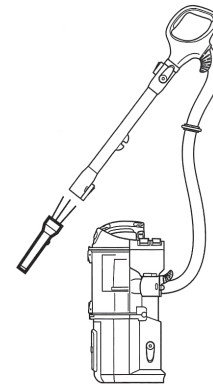

#### STEP 2

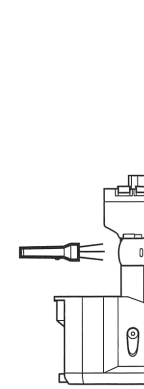

### MAIN UNIT

- 1 Remove floor nozzle and extension wand and shine a flash light up wand and in main body tube to check for possible blockages
- 2 Remove dust cup and hose to check intake opening.

The image shown here is for illustrative purposes only and may be subject to change.

## TROUBLESHOOTING GUIDE

**WARNING:** To reduce the risk of shock and unintended operation, turn power off and unplug unit before servicing.

**Vacuum is not picking up debris. No suction or light suction.** (Refer to Maintenance section for more information.)

- Check filters to see if they need cleaning. Follow instructions for rinsing and drying the filters before re-inserting in the vacuum.
- Dust cup may be full; empty dust cup.
- Check hose, hose connections, nozzle, and accessories for blockages; clear blockages if required.
- Remove any string, carpet fibers, or hair that may be wrapped around the brushroll.

#### Vacuum lifts area rugs.

- Turn off unit to disengage the brushroll. Ensure brushroll is turned off and restart with the POWER button for suction only cleaning.
- Suction is powerful. Take care when vacuuming area rugs or rugs with delicately sewn edges.
- To minimize suction, refer to Suction Control section for more information on how to use.

#### Brushroll does not spin.

- If Brushroll Indicator Light on the floor nozzle turns red, the brushroll has stopped spinning. Immediately turn off and unplug vacuum, disconnect the nozzle, and remove blockage before reconnecting and turning vacuum back on.
- With the power on, recline the handle, which will automatically turn on the brushroll.
- Ensure that the BRUSHROLL button is on for brushroll to spin

#### Vacuum turns off on its own or indicator light flashes red.

This vacuum is equipped with a motor-protective thermostat. If your vacuum overheats, the thermostat will automatically turn the suction motor off. Perform the following steps to restart the thermostat:

1. Turn vacuum off and unplug it.
2. Empty dust cup and clean filters (see Maintenance section).
3. Check for blockages in hose, accessories, and inlet openings.
4. Allow unit to cool for a minimum of 45 minutes.
5. Plug in vacuum and turn it on.
6. Restart the unit using either the POWER or BRUSHROLL buttons.

## REFURBISHED PRODUCT LIMITED NINETY DAYS WARRANTY

The **Refurbished Product Service Center** offers the following WARRANTY to the ORIGINAL purchaser of a product which we have refurbished.

This product that has been refurbished is warranted against any electronic or mechanical defects for a period of NINETY DAYS from the date of the original purchase by the consumer. Since this unit was sold as a refurbished item, the warranty does not apply to any cosmetic appearance items such as scratches. Should a defect occur, the **Refurbished Product Service Center** will repair or, at its option, replace defective unit/parts with new or rebuilt materials without charge for either parts or labor. Replacement unit/parts will be warranted for the remaining portion of the original warranty period.

This warranty does not cover installation or damage from accident, misuse, abuse, improper wiring, incorrect voltage, operating the unit against the instructions in the owner's manual or any product which has been opened, altered, or tampered with.

This warranty does not cover costs for removal and or installation of the unit for repair. Under no circumstances shall the service center be liable for any special, incidental or consequential damages or for any other expenses incurred by reason of use or sale of this product. This warranty is in lieu of any other warranties expressed or implied warranty of merchantability of fitness for particular use or otherwise.

This warranty gives the consumer specific legal rights and they may also have other rights which vary from State to State. Some States do not follow the exclusion or limitation of incidental or consequential damages, hence the above exclusion and limitations may not apply.

**Refurbished Product Service Center**  
13225 Marquardt Avenue Santa Fe Springs, CA 90670.

## WARRANTY REPAIR INFORMATION

If you need service on your unit and this product requires repair during the 90 days warranty period; please go to [www.ConsumerService-Refurbish.com](http://www.ConsumerService-Refurbish.com) or call the **Refurbished Product Service Center** at 562-946-3531 to obtain the required return authorization (RA) number. Pack the unit properly (the original carton is ideal for this purpose) along with a copy of your purchase receipt and a letter describing the problem. Send the unit freight prepaid and insured to:

**Refurbished Product Service Center,**  
Att: Customer Service Department 13225 Marquardt Avenue Santa Fe Springs, CA 90670

Your unit will be promptly repaired and returned to you. We will refuse to accept delivery of the returned unit unless the assigned RA number appears on the outside of the shipping carton.

**Owner's Information**  
(Keep for your permanent records)

NAME: \_\_\_\_\_  
ADDRESS: \_\_\_\_\_  
CITY: \_\_\_\_\_  
STATE: \_\_\_\_\_  
ZIP CODE: \_\_\_\_\_  
PHONE: \_\_\_\_\_  
E-MAIL: \_\_\_\_\_  
MODEL: \_\_\_\_\_  
SERIAL NO.: \_\_\_\_\_



PRINTED IN MEXICO SHNMDL: NV342Q\_B  
TAB Elbrd:J.E. SC: 11-29-2023 OBP: NV342Q\_IB\_160504  
Add: NV341QBL\_NV342QGN\_NV341QPR\_NV341QR\_NV342QBL\_NV342QGN

8 0 4 1 0 9 9 1 3