

# PHILIPS 5 series

# Roku TV

## QUICK GUIDE [805001355]

Please read this manual carefully before operating your unit and retain for future reference.

To download your copy of the complete Owner's Manual:

<http://consumerservicerefurbish.com>

Click on: **Download Owners Manual**  
**On Manufacturer or Brand, select: TV**  
**On Product Type, select: PHILIPS**  
**On Model Number, select: 43PFL5756F7A**

## 1 Using the remote

### How to install the batteries in the remote (Batteries not included)

Open the battery cover by firmly sliding down. Insert 2 AAA (1.5 V) batteries matching the polarity indicated inside battery compartment of the remote.

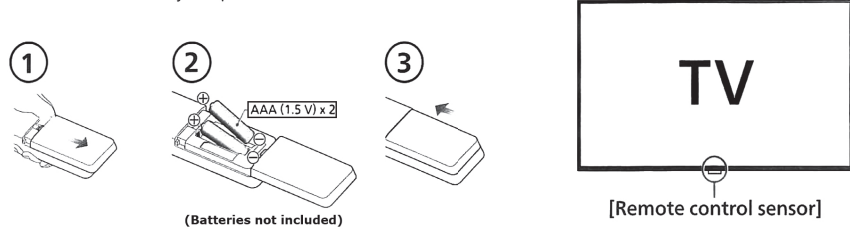

- 1 **Power**  
Turn TV on and off
- 2 **Back**  
Return to previous screen
- 3 **OK**  
Select an option from a menu
- 4 **Instant replay**  
Replay the last few seconds of streaming video
- 5 **RWD scan**  
Rewind streaming video, scroll left one page at a time
- 6 **Home**  
Return to Roku Home screen
- 7 **Directional keypad**  
Move up or down; The left arrow will bring up the antenna TV channel list or Smart Guide. The left and right arrow are used for Live TV Pause to select scenes.
- 8 **Sleep**  
Set the sleep timer
- 9 **Options**  
Access to picture settings, move streaming channel icons and more
- 10 **FWD scan**  
Fast forward streaming video, scroll right one page at a time. This button is also used to fast forward paused live TV using Live TV Pause.
- 11 **Play / Pause**  
Start or pause playback. This button is also used to activate and use the Live TV Pause feature when a 16 GB USB drive is attached to the TV.
- 12 **Featured channel shortcut**  
Lets you directly access featured channels
- 13 **Volume / Mute**  
Increase / Decrease volume and mutes the TV sound

\* The \* gives you easy access to picture settings, display options and more. Try it on every screen.

## 2 Prepare to activate your smart TV

What you need (not included)

- **Wireless router** (needed to connect your TV to the Internet)
- **Computer, tablet, or smartphone** (needed for setup)
- **Internet connection** (needed for streaming)
- **Roku account** (needed to access entertainment across thousands of streaming channels)

Key things to know: A paid subscription or other payments may be required for some streaming channel content. Channel availability is subject to change and varies by country.

### Your Roku account

During guided setup, you will be prompted to create your Roku account online. See more information below.

- Roku accounts are free, and while a valid credit card number is not required to create your account, providing your credit card information makes renting and purchasing entertainment from the Roku Channel Store fast and convenient.
- If you choose to save a payment method, you will be able to seamlessly rent content, download channels and subscribe to services without having to enter your credit card information each time.
- A unique PIN can be added to the account to prevent unauthorized purchases.

**Tip:** Roku does not charge for activation support – **beware of scams.**

## 3 Plug in and turn on TV

Connect the AC power cord to the AC outlet. Press the power button on the TV's remote.

## 4 Follow the on-screen instructions

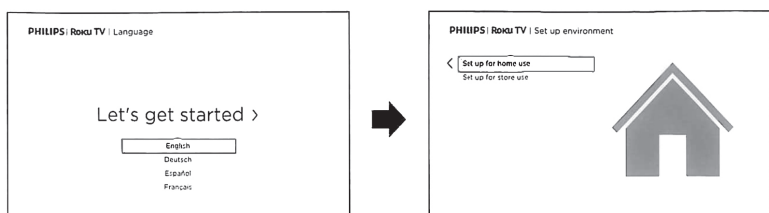

1. Once your Roku TV powers on, follow the on-screen instructions. Your Roku TV will walk you through initial setup and help connect to your preferred wireless network.
2. Your TV will automatically detect wireless networks in your area. Have your network name and password handy and follow the easy on-screen instructions.
  - If you are not ready to connect your TV to a wireless network, you can still use it as a regular TV by selecting "Connect to the Internet later".

3. Once connected your TV will automatically update with the latest software. This can take a few minutes to update. Once you complete guided setup, your TV will automatically update with the latest software. Your new Philips Roku TV automatically receives regular software updates in the background when it's connected to the Internet. This allows it to give you a better experience over time.

## 5 Download the Roku mobile app (optional)

The free Roku mobile app allows you to use your mobile device as a fully functioning remote with voice search and keyboard.

- Download the Roku mobile app on your smartphone or tablet through Google Play or Apple App Store.
- Simply search for "Roku app" and choose the "Roku" app provided by Roku Inc.
- Follow the on-screen prompts and you are on your way.

## 6 Connect antenna or cable (optional)

With the tuner built-in you can connect your TV to antenna or cable (free cable only, does not work with cable TV using a set-top box) and enjoy over-the-air entertainment.

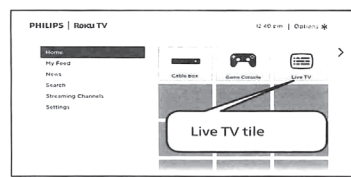

1. When the setup wizard is complete, select the Live TV tile from the home screen.
2. Follow the on-screen instructions.
3. Whenever you want to watch local broadcast TV, select this tile.

• User interface may vary.

### Tip:

While in the antenna TV input, you can use your remote to access additional features.

- D-Pad left: Pressing this key brings up the smart guide, a list of antenna TV channels.
- Play/Pause: Pause live TV for up to 90 minutes when a 16 GB USB drive is connected.
- RWD scan and FWD scan: Allows you to fast forward and rewind while using the Live TV Pause feature.
- D-Pad left and right: Allows you to scroll through the paused Live TV and select scenes.

## 7 Connection overview

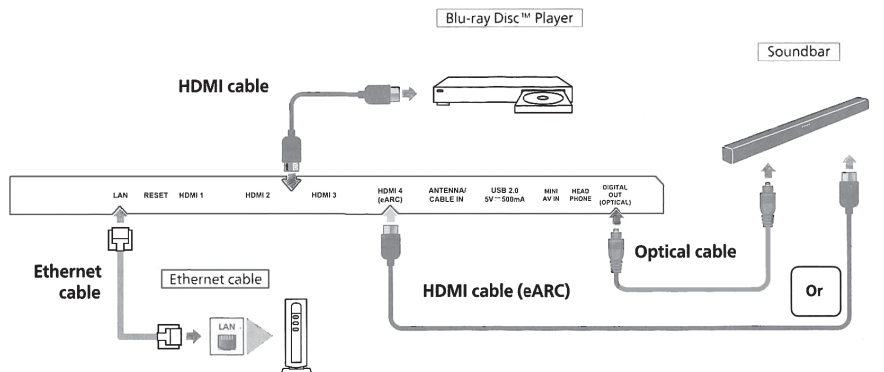

• The cables mentioned in this guide is not supplied with your unit.

## Wall Mount

### Wall mount bracket kit

43PFL5756/F7	Brand: SANUS	Model #: AST16	Screw dimension: M4 x 1.378" (35 mm)
--------------	--------------	----------------	--------------------------------------

- Compatible wall bracket kits are available from third party vendors and will allow mounting of the TV on the wall.
- The recommended wall mount bracket kit (sold separately) allows the mounting of the TV on the wall.
- For detailed information on installing the wall mount, refer to the wall mount instruction book.
- Funai Corporation is not responsible for any damage to the product or injury to yourself or others if you elect to install the TV wall mount bracket or mount the TV onto the bracket on your own.
- The wall mount bracket must be installed by experts.

### Funai Corporation is not liable for these types of accidents or injuries noted below.

- Install the wall mount bracket on a sturdy vertical wall.
- If installed onto a ceiling or slanted wall, the TV and wall mount bracket may fall which could result in a severe injury.
- Do not use screws that are longer or shorter than their specified length. If screws too long are used this may cause mechanical or electrical damage inside the TV set.
- If screws too short are used this may cause the TV set to fall.
- Do not fasten the screws by excessive force. This may damage the product or cause the product to fall, leading to injury.
- For safety reasons use 2 people to mount the TV onto a wall mounting bracket.
- Do not mount the TV onto the wall mounting bracket while your TV is plugged in or Turned On. It may result in an electrical shock injury.

### When installing the unit on the wall, allow this much space.

Top:	11.8" (30 cm)
Left and right side:	5.9" (15 cm)
Bottom:	3.9" (10 cm)

## 8 Troubleshooting

Category	Problem	Tip
Power	No power	<ul style="list-style-type: none"> <li>• Ensure that the AC outlet supplies the proper voltage. Plug another electrical appliance into the AC outlet to ensure that the AC outlet operates normally.</li> <li>• If a power failure occurs, unplug the AC power cord for 1 minute to allow the unit to reset itself.</li> </ul>
Remote	Remote buttons are not functional.	<ul style="list-style-type: none"> <li>• Re-insert or replace the AAA batteries with their polarities (+/-) as indicated on the remote battery area.</li> </ul>
Network	Cannot connect the network.	<ul style="list-style-type: none"> <li>• Check if your router and/or modem is properly connected.</li> <li>• Check if the Ethernet cable connection between the TV and your router or modem is properly secured.</li> <li>• Power cycle the router and/or modem.</li> <li>• Check your network settings.</li> </ul>
	Slow Data Connection or buffering.	<ul style="list-style-type: none"> <li>• Check the settings between your router and ISP modem or gateway (if applicable).</li> <li>• Connect to a stable wireless connection from home wireless or wired network.</li> <li>• The use of mobile hot spots or public wireless connections is not recommended.</li> </ul>
Picture on HDMI Input	Television has sound with no picture or abnormal picture.	<ul style="list-style-type: none"> <li>• HDMI EDID Version setting is set to a different mode than your source device.</li> <li>• Change the resolution output of your source device.</li> </ul>
Sound on HDMI with external devices	Television has no sound.	<ul style="list-style-type: none"> <li>• Please check to be sure the device is connected to the HDMI 2 (ARC) input on the TV.</li> </ul>

### License

Funai Corporation, Inc. hereby offers to deliver, upon request, a copy of the complete corresponding source code for the copyrighted open source code packages, on an "AS IS" basis, used in this product for which such offer is requested by the respective licenses. This offer is valid up to three years after the product purchase to anyone in receipt of this information. To obtain source code, please contact Funai Corporation, Inc. You should write to Funai Service Corporation OSS Request, 2425 Spiegel Drive, Groveport, OH 43125, USA. Funai Corporation, Inc. disclaims any and all warranties and representations with respect to such software and related source code including quality, reliability, usability, and accuracy, and further disclaim all express, implied, statutory or otherwise, including without limitation, any implied warranties of title, non-infringement, merchantability, or fitness for a particular purpose. Funai Corporation, Inc. shall not be liable to make any corrections to the open source software or source code or to provide any support or assistance with respect to it. Funai Corporation, Inc. disclaims any and all liability arising out of or in connection with the use of this software and/or source code.



# READ THIS FIRST



**PLEASE KEEP PACKING MATERIALS FOR FUTURE TRANSPORTATION!**

**DO NOT RETURN TO STORE**

**We are ready to help! Contact us first with any questions**

For installing the stands, see the back of this sheet. The information is intended for regular installation of this TV (not for wall mount installation).

## 1 Getting started

**!** Please read the entire instructions once before following them step by step.

A wide open space is recommended for assembly.

Be careful not to injure your fingers and keep children away during assembly.

A Phillips-head screwdriver is required to fasten the stands to the TV set.

It is recommended that two or more people remove the TV set from the box.

(TOOL NOT INCLUDED)



## 2 What's in the box



ST4 x 0.787" (20 mm)

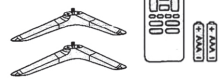

**!** Thin TVs can easily bend. To avoid damage to this TV and its screen, it **MUST NOT** be carried in a horizontal position when being moved.



• Accessory type and quantity may vary depending on the model.

• The remote control vary depend of model: The buttons on the remote control may have a different name or location than the remote control shows in this manual.

## 3 Unpacking

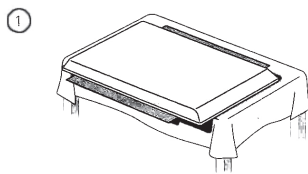

**!** Carefully lay the TV set, with the screen side down, on the front cardboard as shown in the figure.

43" TV  
Téléviseur 43"

Cover a table top with a cloth or blanket to avoid damage to the TV screen, Hold both sides of the TV set to place on the table.

## 4 Installing the stands

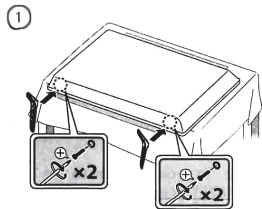

**!** Fasten the stands to the TV with 4 screws (included). While fastening the screws, hold the stand to prevent it from falling.

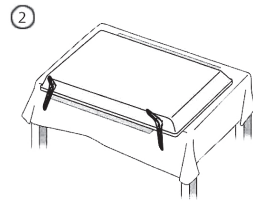

Both stands now be securely fastened.

## 5 Lifting the TV set

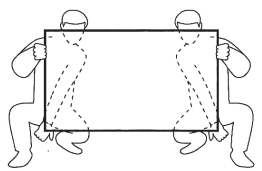

## 6 Connecting the power and antenna, cable or satellite

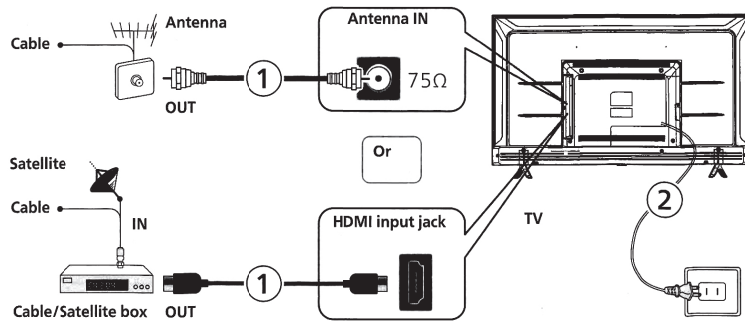

## 7 Connection overview

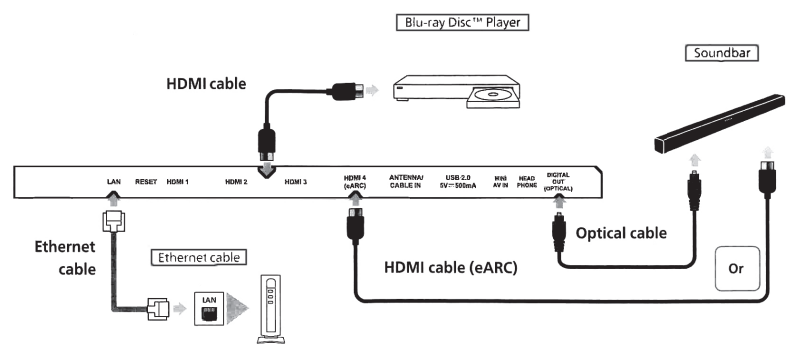

### Wall Mount

#### Wall mount bracket kit

43PFL5756/F7	Brand: SANUS	Model #: AST16	Screw dimension: M4 x 1.378" (35 mm)
<p>Compatible wall bracket kits are available from third party vendors and will allow mounting of the TV on the wall.</p> <p>The recommended wall mount bracket kit (sold separately) allows the mounting of the TV on the wall.</p> <p>For detailed information on installing the wall mount, refer to the wall mount instruction book.</p> <p>Funai Corporation is not responsible for any damage to the product or injury to yourself or others if you elect to install the TV wall mount bracket or mount the TV onto the bracket on your own.</p> <p>The wall mount bracket must be installed by experts.</p> <p><b>When installing the unit on the wall, allow this much space.</b></p> <p>Top: 11.8" (30 cm) Left and right side: 5.9" (15 cm) Bottom: 3.9" (10 cm)</p> <p><b>Funai Corporation is not liable for these types of accidents or injuries noted below.</b></p> <ul style="list-style-type: none"> <li>Install the wall mount bracket on a sturdy vertical wall.</li> <li>If installed onto a ceiling or slanted wall, the TV and wall mount bracket may fall which could result in a severe injury.</li> <li>Do not use screws that are longer or shorter than their specified length. If screws too long are used this may cause mechanical or electrical damage inside the TV set.</li> <li>If screws too short are used this may cause the TV set to fall.</li> <li>Do not fasten the screws by excessive force. This may damage the product or cause the product to fall, leading to injury.</li> <li>For safety reasons use 2 people to mount the TV onto a wall mounting bracket.</li> <li>Do not mount the TV onto the wall mounting bracket while your TV is plugged in or Turned On. It may result in an electrical shock injury.</li> </ul>			

- The image shown here is for illustrative purposes only and may be subject to change.
- The cables mentioned in this guide is not supplied with your unit.

### REFURBISHED PRODUCT LIMITED NINETY DAYS WARRANTY

The **Refurbished Product Service Center** offers the following WARRANTY to the ORIGINAL purchaser of a product which we have refurbished.

This product that has been refurbished is warranted against any electronic or mechanical defects for a period of NINETY DAYS from the date of the original purchase by the consumer. Since this unit was sold as a refurbished item, the warranty does not apply to any cosmetic appearance items such as scratches. Should a defect occur, the **Refurbished Product Service Center** will repair or, at its option, replace defective unit/parts with new or rebuilt materials without charge for either parts or labor. Replacement unit/parts will be warranted for the remaining portion of the original warranty period.

This warranty does not cover installation or damage from accident, misuse, abuse, improper wiring, incorrect voltage, operating the unit against the instructions in the owner's manual or any product which has been opened, altered, or tampered with.

This warranty does not cover costs for removal and or installation of the unit for repair. Under no circumstances shall the service center be liable for any special, incidental or consequential damages or for any other expenses incurred by reason of use or sale of this product. This warranty is in lieu of any other warranties expressed or implied warranty of merchantability of fitness for particular use or otherwise.

This warranty gives the consumer specific legal rights and they may also have other rights which vary from State to State. Some States do not follow the exclusion or limitation of incidental or consequential damages, hence the above exclusion and limitations may not apply.

**Refurbished Product Service Center**  
13225 Marquardt Avenue Santa Fe Springs, CA 90670.

### WARRANTY REPAIR INFORMATION

If you need service on your unit and this product requires repair during the 90 days warranty period; please go to [www.ConsumerServiceRefurbish.com](http://www.ConsumerServiceRefurbish.com) or call the **Refurbished Product Service Center** at 562-946-3531 to obtain the required return authorization (RA) number. Pack the unit properly (the original carton is ideal for this purpose) along with a copy of your purchase receipt and a letter describing the problem. Send the unit freight prepaid and insured to:

**Refurbished Product Service Center,**  
Att: Customer Service Department 13225 Marquardt Avenue Santa Fe Springs, CA 90670

Your unit will be promptly repaired and returned to you. We will refuse to accept delivery of the returned unit unless the assigned RA number appears on the outside of the shipping carton.

**Owner's Information**  
(Keep for your permanent records)

NAME: \_\_\_\_\_  
ADDRESS: \_\_\_\_\_  
CITY: \_\_\_\_\_  
STATE: \_\_\_\_\_  
ZIP CODE: \_\_\_\_\_  
PHONE: \_\_\_\_\_  
E-MAIL: \_\_\_\_\_  
MODEL: \_\_\_\_\_  
SERIAL NO.: \_\_\_\_\_

