

# SAMSUNG USER MANUAL

Please read this manual carefully before operating your unit and retain for future reference.

814100169

## SAFETY INFORMATION

- The following also applies to the Wireless Subwoofer (PS-WB44T).

## SAFETY WARNINGS

TO REDUCE THE RISK OF ELECTRIC SHOCK, DO NOT REMOVE THE COVER (OR BACK). NO USER-SERVICEABLE PARTS ARE INSIDE. REFER SERVICING TO QUALIFIED SERVICE PERSONNEL. Refer to the table below for an explanation of symbols which may be on your Samsung product.

	<b>CAUTION</b> <b>RISK OF ELECTRIC SHOCK.</b> <b>DO NOT OPEN.</b>	
	This symbol indicates that high voltage is present inside. It is dangerous to make any kind of contact with any internal part of this product.	
	This symbol indicates that this product has included important literature concerning operation and maintenance.	
	Class II product : This symbol indicates that a safety connection to electrical earth (ground) is not required. If this symbol is not present on a product with a power cord, the product MUST have a reliable connection to protective earth (ground).	
	AC voltage : Rated voltage marked with this symbol is AC voltage.	
	DC voltage : Rated voltage marked with this symbol is DC voltage.	
	Caution. Consult Instructions for use : This symbol instructs the user to consult the user manual for further safety related information.	

### WARNING

- To reduce the risk of fire or electric shock, do not expose this appliance to rain or moisture.
- To prevent injury, this apparatus must be securely attached to the floor/wall in accordance with the installation instructions.
- This product contains chemicals known to the State of California to cause cancer and birth defects or other reproductive harm.

### CAUTION

- Do not expose this apparatus to dripping or splashing. Do not put objects filled with liquids, such as vases, on the apparatus.
- To turn this apparatus off completely, you must pull the power plug out of the wall socket. Consequently, the power plug must be easily and readily accessible at all times.

### FCC NOTE (for U.S.A.):

#### FCC Compliance Statement :

This device complies with Part 15 of the FCC Rules.

Operation is subject to the following two conditions:

- (1) This device may not cause harmful interference, and (2) this device must accept any interference received, including interference that may cause undesired operation.

#### FCC Caution :

- Any changes or modifications not expressly approved by the party responsible for compliance could void the user's authority to operate this equipment.
- This product satisfies FCC regulations when shielded cables and connectors are used to connect the unit to other equipment. To prevent electromagnetic interference with electric appliances, such as radios and televisions, use shielded cables and connectors for connections.

#### Class B FCC Statement

This equipment has been tested and found to comply with the limits for a Class B digital device, pursuant to Part 15 of the FCC Rules. These limits are designed to provide reasonable protection against harmful interference in a residential installation. This equipment generates, uses and can radiate radio frequency energy and, if not installed and used in accordance with the instructions, may cause harmful interference to radio communications. However, there is no guarantee that interference will not occur in a particular installation. If this equipment does cause harmful interference to radio or television reception, which can be determined by turning the equipment off and on, the user is encouraged to try to correct the interference by one of the following measures:

- Reorienting or relocating the receiving antenna.
- Increasing the separation between the equipment and receiver.
- Connecting the equipment to an outlet that is on a different circuit than the radio or TV.
- Consulting the dealer or an experienced radio/TV technician for help.

## 01 CHECKING THE COMPONENTS

Soundbar Main Unit / Subwoofer / Remote Control / Power Cord (Subwoofer, Soundbar) / Optical Cable / Wall Mount Guide / Holder-Screw / Bracket-Wall Mount / Screw (M4 x L10)

### NOTES

- For more information about the power supply and power consumption, refer to the label attached to the product. (Label: Bottom of the Soundbar Main Unit)
- To purchase additional components or optional cables, contact a Service Center.
- Design and specifications are subject to change without prior notice.

### FCC Radiation Exposure Statement :

This equipment complies with FCC radiation exposure limits set forth for an uncontrolled environment. This equipment should be installed and operated so there is at least 8 inches (20 cm) between the radiator and your body. This device and its antenna(s) must not be co-located or operated in conjunction with any other antenna or transmitter.

### CALIFORNIA USA ONLY (Applicable for networking models only.)

This Perchlorate warning applies only to primary CR(Manganese Dioxide) Lithium coin cells in the product sold or distributed ONLY in California USA "Perchlorate Material - special handling may apply, See [www.dtsc.ca.gov/hazardouswaste/perchlorate](http://www.dtsc.ca.gov/hazardouswaste/perchlorate)."

Dispose unwanted electronics through an approved recycler. To find the nearest recycling location, go to our website: [www.samsung.com/recycling](http://www.samsung.com/recycling) Or call, 1-800-SAMSUNG

**WARNING: Cancer and Reproductive Harm - www.P65Warnings.ca.gov.**

### Important Safety Instructions

Read these operating instructions carefully before using the unit. Follow all the safety instructions listed below. Keep these operating instructions handy for future reference.

- Read these instructions.
- Keep these Instructions.
- Heed all warnings.
- Follow all instructions.
- Do not use this apparatus near water.
- Clean only with dry cloth.
- Do not block any ventilation openings. Install in accordance with the manufacturer's instructions.
- Do not install near any heat sources such as radiators, heat registers, stoves, or other apparatus (including amplifiers) that produce heat.
- Do not defeat the safety purpose of the polarized or grounding-type plug. A polarized plug has two blades with one wider than the other. A grounding type plug has two blades and a third grounding prong. The wide blade or the third prong are provided for your safety. If the provided plug does not fit into your outlet, consult an electrician for replacement of the obsolete outlet.
- Protect the power cord from being walked on or pinched particularly at plugs, convenience receptacles, and the point where they exit from the apparatus.
- Only use attachments/accessories specified by the manufacturer.
- Use only with the cart, stand, tripod, bracket, or table specified by the manufacturer, or sold with the apparatus. When a cart is used, use caution when moving the cart/apparatus combination to avoid injury from tip-over.
- Unplug this apparatus during lightning storms or when unused for long periods of time.
- Refer all servicing to qualified service personnel. Servicing is required when the apparatus has been damaged in any way, such as power-supply cord or plug is damaged, liquid has been spilled or objects have fallen into the apparatus, the apparatus has been exposed to rain or moisture, does not operate normally, or has been dropped.

## PRECAUTIONS

- Ensure that the AC power supply in your house complies with the power requirements listed on the identification sticker located on the bottom of your product. Install your product horizontally, on a suitable base (furniture), with enough space around it for ventilation (3~4 inches). Make sure the ventilation slots are not covered. Do not place the unit on amplifiers or other equipment which may become hot. This unit is designed for continuous use. To fully turn off the unit, disconnect the AC plug from the wall outlet. Unplug the unit if you intend to leave it unused for a long period of time.
- During thunderstorms, disconnect the AC plug from the wall outlet. Voltage peaks due to lightning could damage the unit.
- Do not expose the unit to direct sunlight or other heat sources. This could lead to overheating and cause the unit to malfunction.
- Protect the product from moisture (i.e. vases), and excess heat (e.g. a fireplace) or equipment creating strong magnetic or electric fields. Unplug the power cable from the AC wall socket if the unit malfunctions. Your product is not intended for industrial use. It is for personal use only. Condensation may occur if your product has been stored in cold temperatures. If transporting the unit during the winter, wait approximately 2 hours until the unit has reached room temperature before using.
- The battery used with this product contains chemicals that are harmful to the environment. Do not dispose of the battery in the general household trash. Do not expose the battery to excess heat, direct sunlight, or fire. Do not short circuit, disassemble, or overheat the battery. **CAUTION:** Danger of explosion if the battery is replaced incorrectly. Replace only with the same or equivalent type.

## 02 PRODUCT OVERVIEW

### Front Panel / Top Panel of the Soundbar

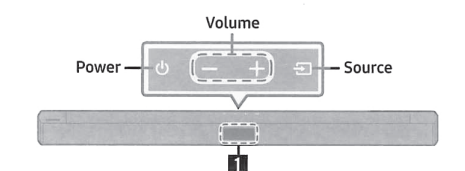

- Display**  
Press the **(Source)** button and the mode to be changed appears on the display. **(D.IN / BT / USB)**

### Bottom Panel of the Soundbar

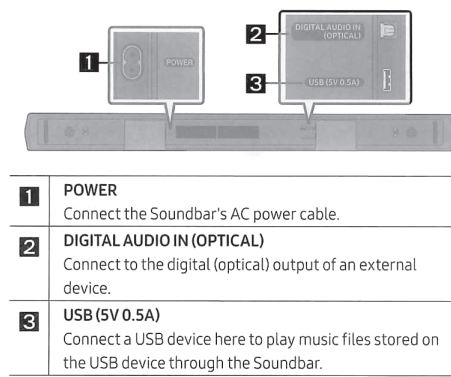

- POWER**  
Connect the Soundbar's AC power cable.
- DIGITAL AUDIO IN (OPTICAL)**  
Connect to the digital (optical) output of an external device.
- USB (5V 0.5A)**  
Connect a USB device here to play music files stored on the USB device through the Soundbar.

## 03 CONNECTING THE SOUNDBAR

### Connecting the power and units

- For more information about the required electrical power and power consumption, refer to the label attached to the product. (Label: Bottom of the Soundbar Main Unit)

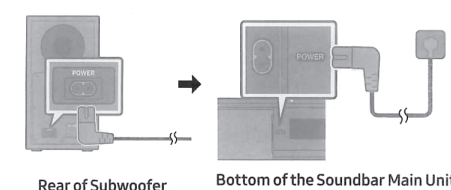

### Manually connecting the Subwoofer

#### 1 - 2 - 3 - 4

- Subwoofer**  
Press the **ID SET** button on the subwoofer. The **LINK** LED indicator on the subwoofer starts blinking blue fast. Wait for 5 seconds. The **LINK** LED indicator on the subwoofer stops blinking and glows a solid blue (connection complete).
- Remote Control**  
Press the **PAUSE** button on the remote control for at least 5 seconds. The **LINK** LED indicator on the subwoofer starts blinking blue fast.
- Soundbar**  
Press the **ID SET** button on the soundbar.
- Connection complete**  
The **LINK** LED indicator stops blinking and glows a solid blue (connection complete).

### NOTES

- If you use a device that uses the same frequency (5.8GHz) as the Soundbar near the Soundbar, interference may cause some sound interruption.
- The maximum transmission distance of the main unit's wireless signal is about 32.8 ft (10 m), but may vary depending on your operating environment.

## 04 CONNECTING WITH A CABLE

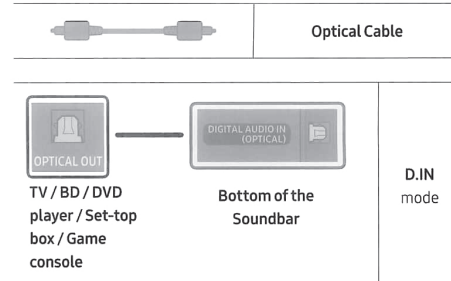

### NOTE

- When you use an optical cable and the terminals have covers, be sure to remove the covers.

Accessory type and quantity may vary depending on the model.

The image shown here is for illustrative purposes only and may be subject to change.

The cables mentioned in this guide is not supplied with your unit.

## 05 CONNECTING WIRELESSLY

### Connecting a TV or Bluetooth Device via Bluetooth

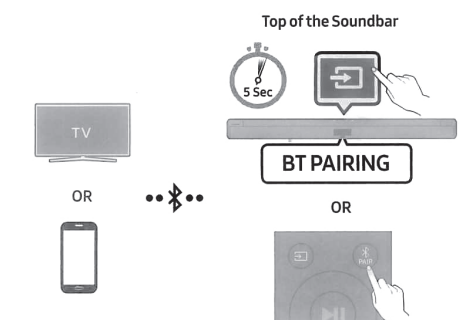

### What is the difference between BT READY and BT PAIRING?

- BT READY** : In this mode, you can search for previously connected TVs or connect a previously connected mobile device to the Soundbar.
- BT PAIRING** : In this mode, you can connect a new device to the Soundbar. (Press the **PAIR** button on the remote control or press and hold the **(Source)** button on the top of the Soundbar for more than 5 seconds while the Soundbar is in "BT" mode.)

### NOTES

- If asked for a PIN code when connecting a Bluetooth device, enter <0000>.
- If the Soundbar is not found on your TV's Bluetooth device list due to influences from the surrounding environment, refer to "Soundbar does not appear on the Bluetooth device list of the TV." in "06 TROUBLESHOOTING".

## 06 TROUBLESHOOTING

Refer to the instructions below if this product does not function properly. If the problem you are experiencing is not listed below or if the instructions below do not help, turn off the product, disconnect the power cord, and contact a Service Center.

### Soundbar does not turn on.

- Check whether the power cord of the Soundbar is correctly inserted into the outlet.

### Soundbar works erratically.

- After removing the power cord, insert it again.
- Try again after resetting the product.
- If there is no signal, the Soundbar automatically turns off after a certain period of time. Turn on the power.

### If the remote control does not work.

- Point the remote directly at the Soundbar.
- Replace the batteries with new ones.

### Soundbar does not output any sound.

- The volume of the Soundbar is too low or muted. Adjust the volume.
- When any external device (STB, Bluetooth device, mobile device, etc.) is connected, adjust the volume of the external device.
- For sound output of the TV, select Soundbar. (Samsung TV: Home ( ) → Menu → Settings ( ) → All Settings ( ) → Sound → Sound Output → Select Soundbar)
- Remove the cable from the Soundbar and then reconnect it.

### Subwoofer does not output any sound.

- Check whether the LED on the rear of the Subwoofer lights in blue. Reconnect it when the blue LED blinks or the red LED lights.

### Soundbar does not connect via Bluetooth.

- When connecting a new device, switch to "BT PAIRING" for connection. (Press the **PAIR** button on the remote control or press the **(Source)** button on the body for at least 5 seconds.)
- Reconnect it after removing the Bluetooth speaker list on the device to connect. (Samsung TV: Home ( ) → Menu → Settings ( ) → All Settings ( ) → Sound → Sound Output → Bluetooth Speaker List)

### Soundbar does not appear on the Bluetooth device list of the TV.

- Disconnect the power cord of the Soundbar completely and reconnect, and then try searching again.
- Connect the TV and Soundbar with an optical cable, and select the "D.IN" mode by pressing the **(Source)** button on the top of the Soundbar. See if the audio output works normally, and try searching again.

### Sound drops out when connected via Bluetooth.

- Some devices can cause radio interference if they are located too close to the Soundbar. e.g. microwaves, wireless routers, etc.
- If your device that is connected via Bluetooth moves too far away from the Soundbar, it may cause the sound to drop out. Move the device closer to the Soundbar.
- If a part of your body is in contact with the Bluetooth transceiver or the product is installed on metal furniture, sound may drop out. Check the installation environment and conditions for use.

### Soundbar does not turn on automatically with the TV.

- When you turn off the Soundbar while watching TV, power synchronization with the TV is disabled. First turn off the TV.

- The ENERGY STAR Program has been to reduced greenhouse gas emissions and save energy through voluntary labeling.
- Power management setting of this product have been enabled by default, and have various timing setting from 1 minutes to 5 hours.
- The product can wake with a button press on the chassis from sleep mode.

### ENERGY STAR qualified model only (The other models)

- As an ENERGY STAR Partner, Samsung has determined that this product or product models meets the ENERGY STAR guideline for energy efficiency.

To send inquiries and requests for questions regarding open sources, contact Samsung Open Source (<http://opensource.samsung.com>)

## 07 LICENSE



Dolby, Dolby Audio, and the double-D symbol are trademarks of Dolby Laboratories Licensing Corporation. Manufactured under license from Dolby Laboratories. Confidential unpublished works. Copyright 1992-2019 Dolby Laboratories. All rights reserved.



For DTS patents, see <http://patents.dts.com>. Manufactured under license from DTS Licensing Limited. DTS, the Symbol, DTS in combination with the Symbol, and DTS 2.0 Channel are registered trademarks or trademarks of DTS, Inc. in the United States and/or other countries. © DTS, Inc. All Rights Reserved.



The Bluetooth® word mark and logos are registered trademarks owned by Bluetooth SIG, Inc. and any use of such marks by Samsung Electronics Co., Ltd. is under license. Other trademarks and trade names are those of their respective owners.



### [ENERGY STAR]

#### ENERGY STAR qualified model only

- Your Samsung product is ENERGY STAR qualified in its factory default setting. Change to certain features, settings and functionality in this product can change the power consumption, possibly beyond the limits required for ENERGY STAR qualification.
- Environmental Protection Agency and Department of Energy. ENERGY STAR is a joint program of the Government agencies, designed to promote energy efficient products and practices.

Refer to [www.energystar.gov](http://www.energystar.gov) for more information of the ENERGY STAR Program.

#### ENERGY STAR qualified model only

##### (Applicable to Thin Client models only)

As an ENERGY STAR® Partner, SAMSUNG has determined that this product meets the ENERGY STAR® guidelines for energy efficiency.

## 08 IMPORTANT NOTES ABOUT SERVICE

- Figures and illustrations in this User Manual are provided for reference only and may differ from actual product appearance.
- An administration fee may be charged if either:
  - a. An engineer is called out to your home at your request and there is no defect in the product.
  - b. You bring the unit to a repair center and there is no defect in the product.
- You will be advised of the amount of the administration fee before any work is done or a home visit is made.
- If you have a problem with this product, we strongly recommend you read the appropriate section of this manual, contact a service center for a repair.

## 09 SPECIFICATIONS AND GUIDE

### Specifications

<b>Model Name</b>	USB
	HW-B43C
	5V/0.5A
<b>Weight</b>	<b>Dimensions (W x H x D)</b>
3.1 lbs (1.4 kg)	33.8 x 2.3 x 3.0 inches (858.8 x 59.0 x 75.0 mm)
<b>Operating Temperature Range</b>	<b>Operating Humidity Range</b>
+41°F to +95°F (+5°C to +35°C)	10% ~ 75%
<b>AMPLIFIER</b>	
<b>Rated Output power</b>	
40W x 2, 6 ohm	
<b>Supported play formats</b>	
(DTS 2.0 sound is played in DTS format.)	
LPCM 2ch, Dolby Audio™ (supporting Dolby® Digital), DTS	
<b>Subwoofer Name</b>	
PS-WB44T	
<b>Weight</b>	<b>Dimensions (W x H x D)</b>
9.7 lbs (4.4 kg)	7.1 x 13.5 x 10.7 inches (181.5 x 343.0 x 272.0 mm)
<b>AMPLIFIER</b>	
<b>Rated Output power</b>	
190W	

### NOTES

- Samsung Electronics Co., Ltd reserves the right to change the specifications without notice.
- Weight and dimensions are approximate.

## 02 INSTALLING THE WALL MOUNT

### Installation Precautions

- Install on a vertical wall only.
- Do not install in a place with high temperature or humidity.
- Verify whether the wall is strong enough to support the product's weight. If not, reinforce the wall or choose another installation point.
- Purchase and use the fixing screws or anchors appropriate for the kind of wall you have (plaster board, iron board, wood, etc.). If possible, fix the support screws into wall studs.
- Purchase wall mounting screws according to the type and thickness of the wall you want to mount the Soundbar on.
  - Diameter: M5
  - Length: 1 3/8 inches (35 mm) or longer recommended.
- Connect cables from the unit to external devices before you install the Soundbar on the wall.
- Make sure the unit is turned off and unplugged from the power source before you install it. Otherwise, it may cause an electric shock.

### Components

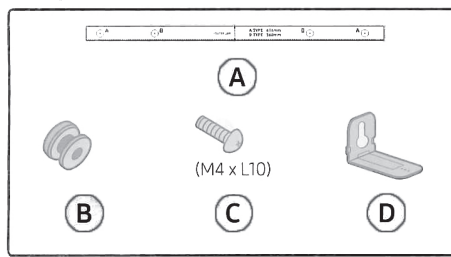

1.

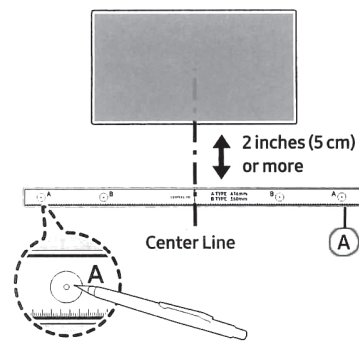

2.

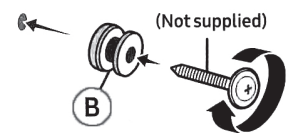

3.

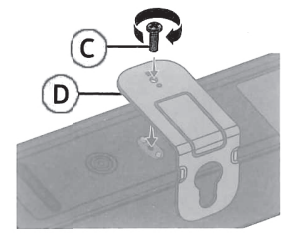

Rear of Soundbar

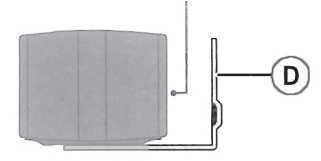

Right end of Soundbar

4.

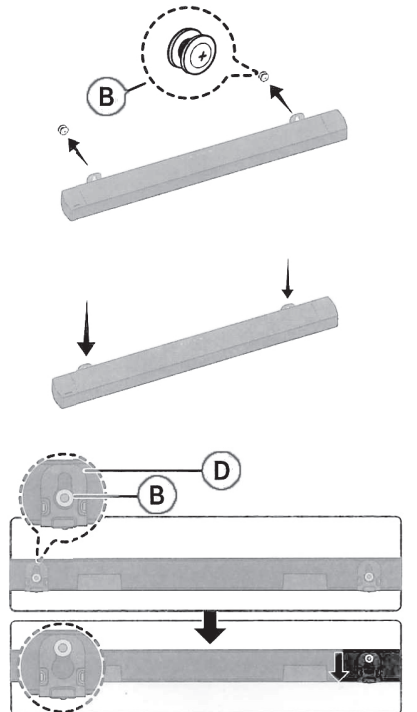

### REFURBISHED PRODUCT LIMITED THIRTY DAY WARRANTY

The **Refurbished Product Service Center** offers the following WARRANTY to the ORIGINAL purchaser of a product which we have refurbished.

This product that has been refurbished is warranted against any electronic or mechanical defects for a period of THIRTY DAYS from the date of the original purchase by the consumer. Since this unit was sold as a refurbished item, the warranty does not apply to any cosmetic appearance items such as scratches. Should a defect occur, the **Refurbished Product Service Center** will repair or, at its option, replace defective unit/parts with new or rebuilt materials without charge for either parts or labor. Replacement unit/parts will be warranted for the remaining portion of the original warranty period.

This warranty does not cover installation or damage from accident, misuse, abuse, improper wiring, incorrect voltage, operating the unit against the instructions in the owner's manual or any product which has been opened, altered, or tampered with.

This warranty does not cover costs for removal and or installation of the unit for repair. Under no circumstances shall the service center be liable for any special, incidental or consequential damages or for any other expenses incurred by reason of use or sale of this product. This warranty is in lieu of any other warranties expressed or implied warranty of merchantability of fitness for particular use or otherwise.

This warranty gives the consumer specific legal rights and they may also have other rights which vary from State to State. Some States do not follow the exclusion or limitation of incidental or consequential damages, hence the above exclusion and limitations may not apply.

**Refurbished Product Service Center**  
13225 Marquardt Avenue Santa Fe Springs, CA 90670

### WARRANTY REPAIR INFORMATION

If you need service on your unit during the 30 day warranty period; please go to [www.ConsumerServiceRefurbish.com](http://www.ConsumerServiceRefurbish.com) or call the Refurbished Product Service Center at 562-946-3531 to obtain the required claim number. Once you obtain your claim number, pack the unit properly (the original carton is ideal for this purpose) along with a copy of your purchase receipt.

Send the unit freight prepaid and insured to:

**Refurbished Product Service Center,**  
**Att: Customer Service Department 13225 Marquardt Avenue Santa Fe Springs, CA 90670**

Your unit will be promptly exchanged and returned to you.

We will refuse to accept delivery of the returned unit unless the assigned claim number appears on the outside of the shipping carton.

**Owner's Information**  
(Keep for your permanent records)

NAME: \_\_\_\_\_  
ADDRESS: \_\_\_\_\_  
CITY: \_\_\_\_\_  
STATE: \_\_\_\_\_  
ZIP CODE: \_\_\_\_\_  
PHONE: \_\_\_\_\_  
E-MAIL: \_\_\_\_\_  
MODEL: \_\_\_\_\_  
SERIAL NO.: \_\_\_\_\_

## 01 USING THE REMOTE CONTROL

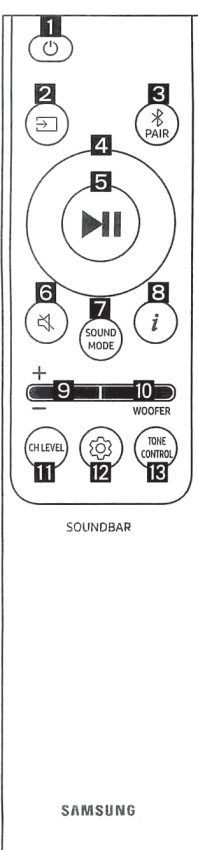

### 1 Power button

### 2 (Source) button

Press to select a source connected to the Soundbar.

### 3 Bluetooth PAIR button

Switch the Soundbar to Bluetooth pairing mode.

### 4 Up/Down/Left/Right buttons

### 5 Play / Pause button

### 6 (Mute) button

### 7 SOUND MODE button

You can select the desired sound effect.

### 8 (Info) button

Press the button to display information about the current function.

### 9 Volume button

### 10 WOOFER (BASS) LEVEL button

Push the button up or down to adjust the level of the woofer (bass).

### 11 CH LEVEL button

When pressed, the settings **CENTER LEVEL** is displayed in sequence. The desired settings can be adjusted using the **Up/Down** buttons.

- When the Rear Speakers (sold separately) are connected, the setting **REAR LEVEL** is supported.

### 12 (Sound Control) button

When pressed, the settings **AUDIO SYNC**, **VOICE ENHANCE ON/OFF**, and **NIGHT MODE ON/OFF** are displayed in sequence. The desired settings can be adjusted using the **Up/Down** buttons.

### 13 TONE CONTROL button

When pressed, the settings **TREBLE**, and **BASS** are displayed in sequence. The desired settings can be adjusted using the **Up/Down** buttons.

(Batteries not included)

The remote control vary depend of model: The buttons on the remote control may have a different name or location than the remote control shows in this manual.

