

Shark WANDVAC POWER PET

Cordless Vacuum

OWNER'S GUIDE

814100218

It's important to read this manual prior to using your new product for the first time.

IMPORTANT SAFETY INSTRUCTIONS

FOR HOUSEHOLD USE ONLY • PLEASE READ ALL INSTRUCTIONS BEFORE USING THIS VACUUM.

If the charging cord plug does not fit fully into the outlet, reverse the plug. If it still does not fit, contact a qualified electrician. DO NOT force into outlet or try to modify to fit.

To reduce the risk of shock and unintended operation, turn off power and remove the battery before servicing.

WARNING

To reduce the risk of injury, fire, electric shock, and property damage resulting from improper use of the appliance, carefully observe the following instructions. This unit contains electrical connections and moving parts that potentially present risk to the user.

WHEN USING AN ELECTRICAL APPLIANCE, BASIC PRECAUTIONS SHOULD ALWAYS BE FOLLOWED, INCLUDING THE FOLLOWING:

Power supply, charging dock, and vacuum contain electrical connections.

- There are **NO** serviceable parts.
- DO NOT** use to vacuum any liquids.
- DO NOT** immerse in water or other liquids.
- If vacuum is damaged, discontinue use.
- To avoid fire, explosion, or injury, inspect vacuum and charging dock for any damage before use. **DO NOT** use damaged vacuum or charging dock.
- DO NOT** use outdoors or on wet surfaces. Use only on dry surfaces.
- If vacuum cleaner is not working as it should, or has been dropped, damaged, left outdoors, or immersed in water, return it to SharkNinja Operating LLC for examination, repair, or adjustment.
- DO NOT** handle charger or vacuum cleaner with wet hands.
- DO NOT** leave vacuum cleaner unattended while powered on.
- Keep vacuum away from heated surfaces.
- Always turn off vacuum before connecting charging dock.
- Use only Shark® chargers and batteries. Other types of batteries may burst, causing injury and damage.
- Use charging dock on flat and stable surfaces only.
- DO NOT** incinerate appliance, even if it is severely damaged, as lithium-ion battery may explode in a fire.
- Servicing can only be performed by a qualified repair person using only identical replacement parts. This will ensure that the safety of the products is maintained.

GENERAL USE

- DO NOT** carry the charger by the cord or yank to disconnect from an outlet; instead, grasp the plug and pull to disconnect.
- Keep charger cord away from heated surfaces.
- Use only as described in this manual.
- Keep your work area well lit.
- To avoid unintentional starting, always turn off the vacuum cleaner and remove the battery pack before picking it up or carrying it, and before attaching or detaching the charger, dust cup, filter, or any accessories.
- DO NOT** put any objects into openings.

- DO NOT** use if any opening is blocked; keep free of dust, lint, hair, or anything that may reduce airflow.
- This vacuum is not a toy, and must not be played with. Children over 8 years old and persons with reduced physical, sensory, or mental capabilities may only use the vacuum with supervision or prior safety instruction and an understanding of the hazards involved. Children may not clean or maintain the vacuum without supervision.
- DO NOT** use without dust cup and filter in place.
- DO NOT** use if airflow is restricted; if the air paths become blocked, turn off the vacuum cleaner. Clear all obstructions and power on again.
- Keep nozzle away from hair, face, fingers, uncovered feet, or loose clothing.
- Only use manufacturer's recommended attachments.
- DO NOT** charge at temperatures below 50°F (10°C) or above 104°F (40°C). Charging improperly or at temperatures outside of the specified range may damage the battery and increase the risk of fire.
- Store the appliance indoors. **DO NOT** use or store it below 37.4°F (3°C). Ensure the appliance is at room temperature before operating.
- Always turn off the vacuum before connecting or disconnecting motorized nozzles, chargers, batteries, or other electrical or mechanical parts.

DUST CUP/FILTERS/ACCESSORIES

Before turning on the vacuum:

- Make sure filter is thoroughly dry after routine cleaning.
- Make sure dust cup and filter are in place after routine maintenance.
- Make sure accessories are free of blockages and keep openings away from face and body.
- Use only Shark® brand filters and accessories. Using other brands will void warranty.

GENERAL CLEANING

- DO NOT** vacuum up hard or sharp objects such as glass, nails, screws, or coins that could damage the vacuum cleaner.
- DO NOT** vacuum up drywall dust, fireplace ash, or embers.
- DO NOT** use as an attachment to power tools for dust collection.
- DO NOT** vacuum up smoking or burning objects such as hot coals, cigarette butts, or matches.

- DO NOT** vacuum up flammable or combustible materials (e.g., lighter fluid, gasoline, or kerosene) or use vacuum in areas where they may be present.
- DO NOT** vacuum up toxic solutions (e.g., chlorine bleach, ammonia, or drain cleaner).
- DO NOT** use in an enclosed space where vapors are present from paint, paint thinner, moth-proofing substances, flammable dust, or other explosive or toxic materials.
- DO NOT** immerse vacuum cleaner in water or other liquids.
- Use extra care when cleaning on stairs.

LITHIUM-ION BATTERY

- The battery is the power source for the appliance. **DO NOT** carry the appliance with your finger on the power button. **DO NOT** charge appliance with the power on.
- Use only the included charging dock XDOCKCWV to charge. Use of incorrect charger may create a risk of fire.
- Use appliance only with included lithium-ion battery XSBT420. Use of any other battery may create a risk of injury and fire.
- Under abusive conditions, liquid may be ejected from the battery. Avoid contact with liquid, as it may cause irritation or burns. If contact occurs, flush with water. If liquid contacts eyes, seek medical help.
- Store the appliance indoors. To maintain battery life, **DO NOT** use or store battery at temperatures below 37.4°F (3°C) or above 104°F (40°C).
- DO NOT** expose battery pack to fire or temperature above 266°F (130°C) as it may cause explosion.
- There are **NO** serviceable parts. To ensure safety, **DO NOT** modify or attempt to repair the battery pack
- DO NOT** use a battery pack of appliance that is damaged or modified. Damaged or modified batteries may exhibit unpredictable behavior resulting in fire, explosion or risk of injury.
- When the battery pack is not in use, keep it away from other metal objects, like paper clips, coins, keys, nails, screws, or other small metal objects. Shorting the battery terminals increases the risk of fire or burns.
- Remove the battery pack from the vacuum before making any adjustments, changing accessories, or storing the appliance. This preventative safety measure reduces the risk of starting the appliance accidentally.

SAVE THESE INSTRUCTIONS

TECHNICAL SPECIFICATIONS

Voltage: 14.4V

CHARGING DOCK ASSEMBLY

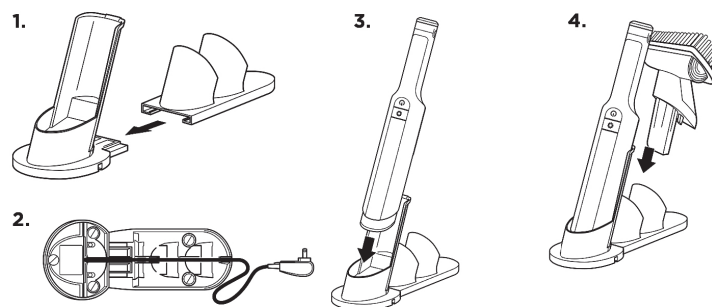

- Slide the **Onboard Accessory Storage Attachment** onto the back of the **Charging Dock** until it clicks into place.
- Route the cord through the grooves in the bottom of the charging dock and onboard accessory storage attachment, then through the slot in the back.
- Slide the vacuum cleaner into the first opening on the charging dock and stand it up.
- Slide the accessories into the openings on the onboard accessory storage attachment.

NOTE: To ensure the stability of the charging dock, be sure to attach the accessory storage attachment to the charging dock.
NOTE: Be sure to put accessories in the designated slots so the vacuum sits properly in the charging dock. Please see the sticker on the onboard accessory storage attachment for the correct placement of accessories.

NOTE: The images shown here are for illustrative purposes only and may be subject to change.

WHAT'S INCLUDED

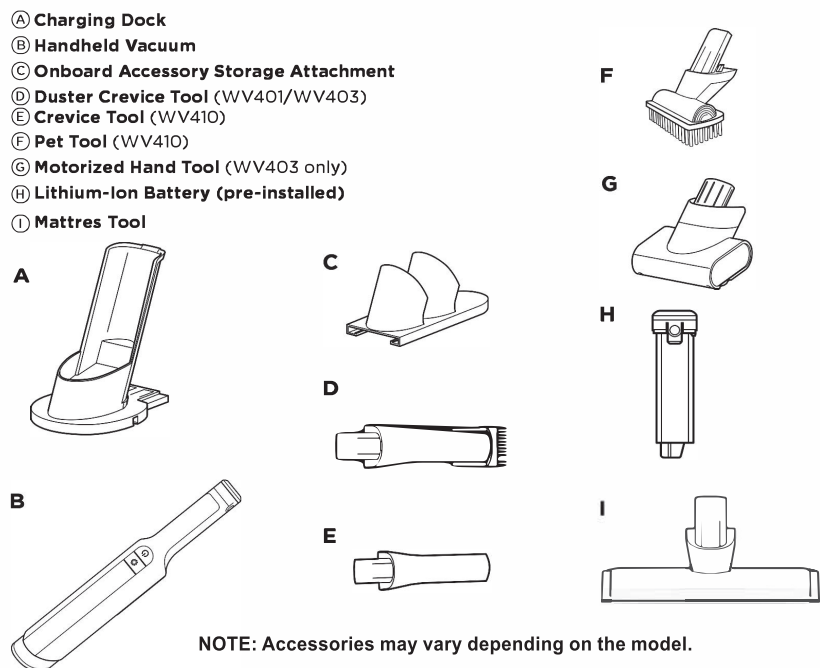

NOTE: Accessories may vary depending on the model.

LI-ION BATTERY

Prior to first use, charge the battery completely.

RUNTIMES PER FULLY CHARGED BATTERY

The maximum operating time in ECO mode with one fully charged battery is 35 minutes.

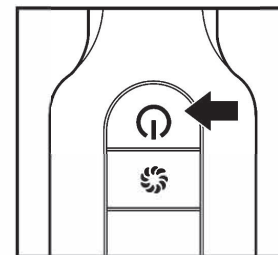
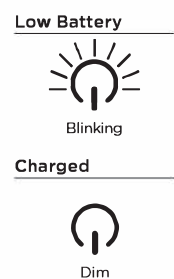
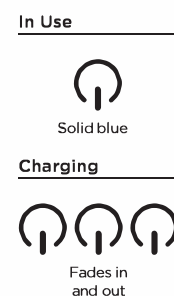

OR

BATTERY LED INDICATOR LIGHTS (WV403)

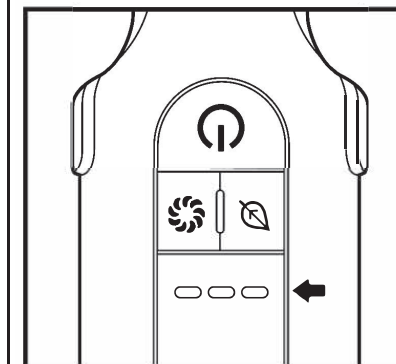

In Use

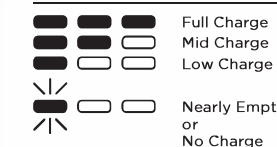

Charging

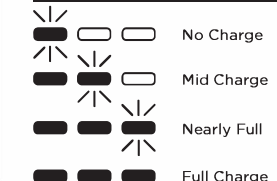

RECYCLING THE LI-ION BATTERY

When the Shark® Li-ion battery needs to be replaced, dispose of it or recycle it in accordance with local ordinances or regulations. In some areas, it is illegal to place spent lithium-ion batteries in the trash or in a municipal solid waste stream. Return spent batteries to an authorized recycling center or to the retailer for recycling. Contact your local recycling center for information on where to drop off the spent battery.

NOTE: The Shark battery, like all lithium-ion batteries, will naturally decrease in capacity over time from the 100% capacity of a new battery.

CHARGING

CHARGING WHILE IN STORAGE

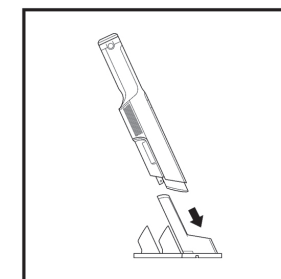

Plug the charging dock into a wall outlet. Charge the vacuum by sliding it into the charging dock nozzle-first.

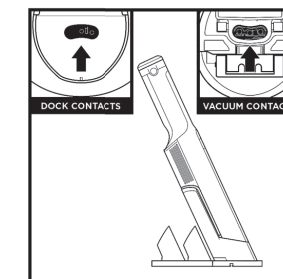

Make sure the contacts on the vacuum are aligned with the contacts on the charging dock. When charging is complete and you need to use the unit again, lift it off the charging dock.

REMOVING THE BATTERY

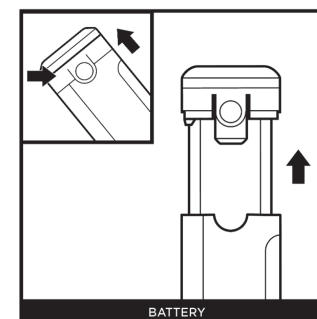

To remove the battery from the hand vacuum, press the release tabs on the battery cap and slide out the battery. To reinstall, slide the battery into the compartment in the handle until it clicks into place.

NOTE: When docked properly, the charging lights on the hand vacuum will blink, indicating that charging has begun. When charging is complete, all three indicator lights will remain on for 5 minutes, then shut off.
NOTE: The main unit comes with a partial charge. For maximum runtime, charge fully before first use (approximately 3.5 hours). Leaving the unit plugged in will not damage battery life.

USING YOUR VACUUM

MODES

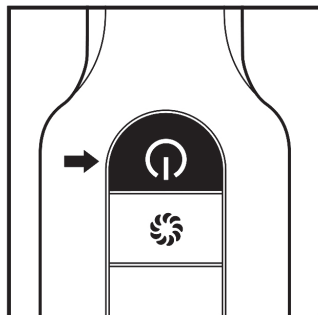

Press the **On/Off** button on the handle to go into Deep Clean mode. Press the power button again to turn off the vacuum.



For an added boost of power, press the **Boost** button. Press again to return to Deep Clean mode.

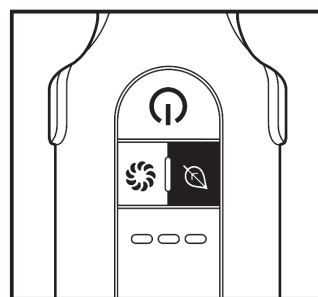

Press the **ECO** button for noise reduction. Press again to return to Deep Clean mode. (WV403 Only)

USING ACCESSORIES

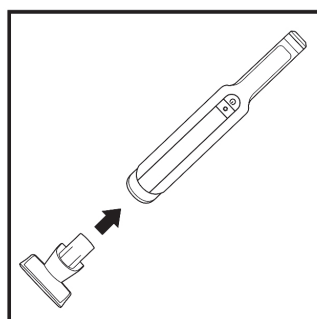

To attach an accessory to the hand vacuum, slide it into the opening in the nozzle. To remove the accessory, slide it off the nozzle.

OR

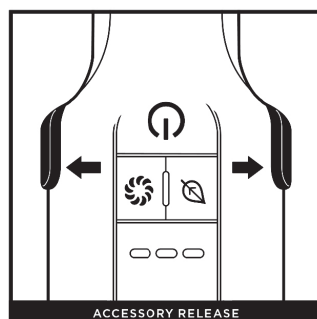

If your vacuum has One-Touch Accessory Release buttons, press the **One-Touch Accessory Release** buttons on either side of the handle to release an accessory from the hand vacuum.

MAINTAINING YOUR VACUUM

EMPTYING THE DUST CUP

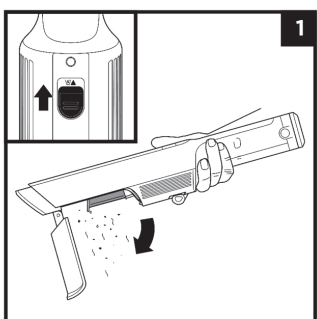

1. With the power off and the hand vacuum positioned over a trash receptacle, slide the Dust Cup release button near the handle, and the dust cup will drop open. Tap the filter screen lightly to knock off dust and debris.

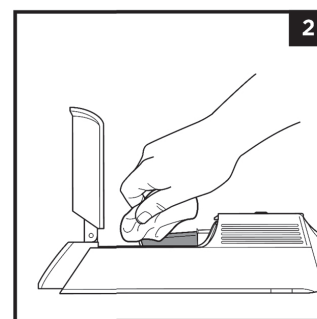

2. Wipe the screen inside the dust cup lightly with a dry cloth to remove dust and dirt.

CLEANING THE FILTER

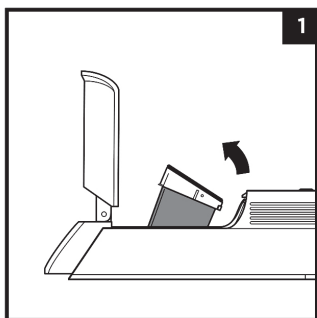

1. With the dust cup removed and the power off, pinch both sides of the filter housing and pivot it upward to access the filter.

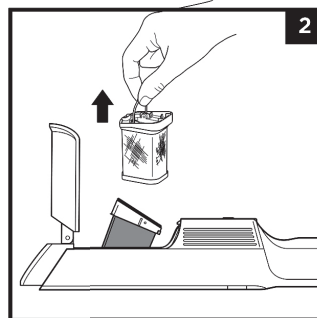

2. Hold the filter housing over a trash receptacle. Lift the fabric filter by the metal ring to remove it from the housing. Tap lightly to remove any dust and debris, then rinse with water only. Let the filter air-dry for at least 24 hours or until completely dry before reinstalling.

CHECKING FOR BLOCKAGES

If you vacuum up a hard or sharp object or notice a noise change while vacuuming, check for blockages or objects caught in the vacuum.

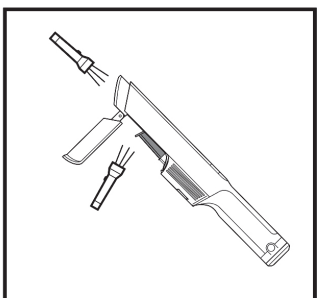

- Turn off the vacuum.
- Check all intake openings to the dust cup and remove any debris or blockages.

MAINTAINING YOUR VACUUM

TROUBLESHOOTING

WARNING: To reduce the risk of shock and unintended operation, turn off power and remove the battery before servicing.

Vacuum is not picking up debris. No suction or light suction. Power button blinks white six times, in 2-second intervals.

(Refer to Checking for Blockages section for more information.)

- Check filters to see if they need cleaning. Follow instructions for rinsing and completely air-drying the filters before reinstalling them.

Vacuum turns off on its own.

There are several possible reasons for the vacuum turning off on its own, including blockages, battery issues, and overheating. If vacuum turns off on its own, perform the following steps:

- Turn on the power and check the battery indicator lights on the vacuum. If recharging is needed, make sure vacuum power is off before charging.
- Empty dust cup and clean filters (See the Cleaning the Dust Cup and Filter section).
- Check accessories and inlet openings and remove any blockages.
- Allow unit and battery to cool for at least 45 minutes, until they return to room temperature.
- Press the On/Off button to restart the vacuum.

• Accessory type and quantity may vary depending on the model.

• The image shown here is for illustrative purposes only and may be subject to change.

POWER BUTTON

WHAT IT MEANS

WHAT TO DO

ECO mode button blinks 5 times in 2-second intervals, then stops.	Charger over voltage or overcurrent.	Make sure that you are using the Shark® charging dock. Do not use any other brands of chargers or batteries. If you are using the correct Shark charging dock and the problem persists, contact a service center.
The Power, Boost mode, and ECO mode buttons are all blinking.	The battery is not properly inserted in the vacuum cleaner.	If available, try another battery. Make sure the battery is installed correctly. To install, slide the battery into the compartment until it clicks into place. If the problem persists, contact a service center.
ECO mode button blinks 10 times in 2-second intervals, then stops.	Overcurrent or short.	With the power off, check the nozzle opening for jams or clogs. Remove any obstructions. If the problem persists, contact a service center.
Boost mode and ECO mode buttons blink 5 times in 2-second intervals, then stop.	Communication.	Contact a service center.
WV410		
Vacuum shuts off. Power button blinks 5 times in 2-second intervals, then stops.	Low voltage start.	With the power off, check the nozzle opening for blockages. Remove any obstructions. Allow unit and battery to cool for at least 45 minutes, returning to room temperature. The battery may need to be charged. If problem persists, contact a service center.
Boost mode button is blinking.	Motor is overheating.	Allow the vacuum cleaner and battery to cool to room temperature for about 45 minutes. While waiting, refer to the cleaning section and remove any blockages. These can impede airflow. The unit can be placed on the charger and will start charging when it has reached normal temperature.
Boost mode button blinks 5 times in 2-second intervals, then stops.	Overspeed.	With the power off, check the nozzle opening for jams or clogs. Remove any obstructions. If the problem persists, contact a service center.

IF YOUR VACUUM HAS THREE BATTERY LED INDICATOR LIGHTS, FOLLOW THE TROUBLESHOOTING BELOW.

BATTERY LED INDICATOR	WHAT IT MEANS	WHAT TO DO
All 3 battery indicator LEDs are blinking. ■ ■ ■	The battery is not properly inserted in the vacuum cleaner.	If available, try another battery. Make sure the battery is installed correctly. To install, slide the battery into the compartment in the handle until it clicks into place. If problem persists, contact a service center.
1st and 3rd LEDs are blinking. ■ □ ■	Motor is overheating.	Allow the vacuum cleaner and battery to cool to room temperature for about 45 minutes. While waiting, refer to the cleaning section and remove any blockages. These can impede airflow. The unit can be placed on the charger and will start charging when it has reached normal temperature.
1st and 2nd LEDs are blinking. ■ ■ □	Overcurrent or short.	With the power off, check the nozzle opening for jams or clogs. Remove any obstructions. If problem persists, contact a service center.
1st LED is blinking. ■ □ □	Battery needs to be charged.	Charge the battery by sliding the vacuum into the charging dock nozzle-first. Make sure the contacts on the vacuum are aligned with the contacts on the charging dock.
2nd LED is blinking. □ ■ □	Overspeed.	With the power off, check the nozzle opening for jams or clogs. Remove any obstructions. If problem persists, contact a service center.
3rd LED is blinking. □ □ ■	Communication.	Contact a service center.
2nd and 3rd LEDs are blinking. □ ■ ■	The charging dock may be defective.	Make sure that you are using the Shark® charging dock. Do not use any other brands of chargers or batteries. If you are using the correct Shark charging dock and the problem persists, contact a service center.

REFURBISHED PRODUCT LIMITED NINETY DAY WARRANTY

The **Refurbished Product Service Center** offers the following WARRANTY to the ORIGINAL purchaser of a product which we have refurbished.

This product that has been refurbished is warranted against any electronic or mechanical defects for a period of NINETY DAYS from the date of the original purchase by the consumer. Since this unit was sold as a refurbished item, the warranty does not apply to any cosmetic appearance items such as scratches. Should a defect occur, the **Refurbished Product Service Center** will repair or, at its option, replace defective unit/parts with new or rebuilt materials without charge for either parts or labor. Replacement unit/parts will be warranted for the remaining portion of the original warranty period.

This warranty does not cover installation or damage from accident, misuse, abuse, improper wiring, incorrect voltage, operating the unit against the instructions in the owner's manual or any product which has been opened, altered, or tampered with.

This warranty does not cover costs for removal and or installation of the unit for repair. Under no circumstances shall the service center be liable for any special, incidental or consequential damages or for any other expenses incurred by reason of use or sale of this product. This warranty is in lieu of any other warranties expressed or implied warranty of merchantability of fitness for particular use or otherwise.

This warranty gives the consumer specific legal rights and they may also have other rights which vary from State to State. Some States do not follow the exclusion or limitation of incidental or consequential damages, hence the above exclusion and limitations may not apply.

Refurbished Product Service Center
13225 Marquardt Avenue Santa Fe Springs, CA 90670

WARRANTY REPAIR INFORMATION

If you need service on your unit during the 90 day warranty period; please go to www.ConsumerServiceRefurbish.com or call the Refurbished Product Service Center at 562-946-3531 to obtain the required claim number. Once you obtain your claim number, pack the unit properly (the original carton is ideal for this purpose) along with a copy of your purchase receipt. Send the unit freight prepaid and insured to:

Refurbished Product Service Center,
Att: Customer Service Department 13225 Marquardt Avenue Santa Fe Springs, CA 90670

Your unit will be promptly exchanged and returned to you.

We will refuse to accept delivery of the returned unit unless the assigned claim number appears on the outside of the shipping carton.

Owner's Information
(Keep for your permanent records)

NAME: _____

ADDRESS: _____

CITY: _____ STATE: _____

ZIP CODE: _____

PHONE: _____

E-MAIL: _____

MODEL: _____

SERIAL NO.: _____

PRINTED IN MEXICO Elbrd: J.E.
OBPN: WV410Series_IB_E_MP_220817
SC: 03-22-2024_TAB SHNMDL: QV410Q_B

814100218

