



NINJA WOODFIRE™ OUTDOOR OVEN

OO100 Series | Owner's Guide

814100208

"Recipe book is not included"



IMPORTANT SAFETY INSTRUCTIONS

FOR OUTDOOR USE ONLY • READ ALL INSTRUCTIONS BEFORE USE



Read and review instructions to understand operation and use of product.



Indicates the presence of a hazard that can cause personal injury, death or substantial property damage if the warning included with this symbol is ignored.



Avoid contact with hot surface. Always use hand protection to avoid burns.



For outdoor use only.

⚠ WARNING

Failure to follow these instructions could result in electric shock, fire or burn hazard which could cause property damage, personal injury, or death. When using electrical appliances, basic safety precautions should always be followed, including the following:

- 1** To eliminate a choking hazard for young children, discard all packaging materials immediately upon unpacking.
- 2** This appliance is for outdoor household use only.
- 3** **DO NOT** use this appliance for anything other than its intended use. Misuse may cause injury.
- 4** **DO NOT** use in moving vehicles or boats.
- 5** This appliance can be used by persons with reduced physical, sensory, or mental capabilities or lack of experience and knowledge if they have been given supervision or instruction concerning use of the appliance in a safe way and understand the hazards involved.
- 6** To avoid property damage from flame or heat, maintain a minimum distance of 3 feet from rear, sides, and top to walls, rails, or other combustible constructions.
- 7** **DO NOT** touch hot surfaces. Appliance surfaces are hot during and after operation. To prevent burns or personal injury, **ALWAYS** use protective hot pads or insulated oven mitts and use available handles and knobs.
- 8** Use care when opening the oven to avoid burns. **ALWAYS** open door to detent before fully opening to check for any flareup as some foods may cause fats, oils, or grease to splash and create flareup or flame.
- 9** **DO NOT** use oils/fats, such as butter, olive oil, and margarine, when cooking over 500°F to avoid the risk of smoke and property damage due to smoke.
- 10** To prevent burns or personal injury **ALWAYS** use care when interfacing with product. Recommend use of long-handled utensil and protective hot pads or insulated oven mitts.
- 11** Ensure the surface is level, stable, clean, and dry. **DO NOT** place the appliance near the edge of the surface the oven is placed on during operation. **DO NOT** clean this product with a water spray or any spray like items.
- 12** Keep the appliance and its cord out of reach of children. **DO NOT** allow the appliance to be used near, cleaned, or maintained by children. Close supervision is necessary when used near children.
- 13** A short power-supply cord is provided to reduce the risk of children less than 8 years grabbing the cord or becoming entangled and to reduce the risk of people tripping over a longer cord. When using an extension cord it must be specific for use outdoors and must have a "W" marking and tag stating: SUITABLE FOR USE WITH OUTDOOR APPLIANCES.
- 14** **ALWAYS** maintain a minimum safe distance of at least 1 foot (30 cm) from the smoke box during smoking. Small flames can come out from the smoke box if the oven lid is lifted in windy conditions.
- 15** Use only on properly grounded outlet. Connect **ONLY** to GFCI grounded electrical outlet if using an extension cord. Longer detachable power-supply cords or extension cords are available and may be used if care is exercised in their use. If longer detachable power-supply cord or extension is used: The cord should be arranged so that it will not drape over the tabletop where it can be pulled on by children or tripped over unintentionally.

IMPORTANT SAFETY INSTRUCTIONS

FOR OUTDOOR USE ONLY • READ ALL INSTRUCTIONS BEFORE USE

- 16 To avoid burn injury, **ALWAYS** use pellet scoop when adding pellets to smoker box. **DO NOT** add pellets by hand.
- 17 To avoid burn injury and property damage, make sure the lid of the smoke box is fully closed to prevent flames from escaping out of the smoke box.
- 18 Pellets may continue to burn after cook time is complete. **DO NOT** touch or remove the smoke box until the oven has stopped smoking, pellets have completely burned out, and the smoke box has cooled.
- 19 **DO NOT** allow pellets to overflow the smoke box. Doing so will introduce additional oxygen leading to combustion, flame, and damage to the oven which may result in burn injury.
- 20 **ALWAYS** ensure the oven is completely cool before removing the cooking plates or moving the oven to avoid burns or personal injury.
- 21 **DO NOT** use the appliance without the Accessory Frame installed.
- 22 To protect against electrical shock, keep the cord connection dry and off the ground. **DO NOT** immerse cord, plugs, or main unit housing in water or other liquid.
- 23 Regularly inspect the appliance and power cord. **DO NOT** use the appliance if there is damage to the power cord or plug. If the appliance malfunctions or has been damaged in any way, immediately stop use and Contact Service Center.
- 24 **NEVER** use outlet below countertop surface.
- 25 **ALWAYS** ensure the appliance is properly assembled before use.
- 26 **NEVER** connect this appliance to an external timer switch or separate remote-control system.
- 27 **DO NOT** place appliance where the cord may hang over edges of tables or counters or touch hot surfaces.
- 28 Only use recommended accessories included with this appliance or authorized by SharkNinja. The use of accessories or attachments not recommended by SharkNinja may cause a risk of fire or injury.
- 29 Before placing any accessory into the cooker, ensure they are clean and dry.
- 30 **DO NOT** move the appliance when in use.
- 31 **DONOT** cover the air intake vent or air outlet vent while unit is operating. Doing so will prevent even cooking and may damage the oven or cause it to overheat.
- 32 Ensure all accessories are correctly inserted and securely locked into position.
- 33 **DO NOT** use this appliance for deep frying.
- 34 Should a grease fire occur, or the oven emits black smoke, unplug immediately. Wait for smoking to stop before removing any cooking accessories.
- 35 Socket voltages can vary, affecting the performance of the product. To prevent possible illness, **ALWAYS** use an external food thermometer to check that the food is cooked to the recommended temperatures.
- 36 **DO NOT** use heating or any other non-food grade pellets in the grill, due to potential hazardous contaminants and additives that may be present.
- 37 **NEVER** use heating fuel pellets, hardwood, charcoal, liquid fuels, or any other combustible material in the smoke box.
- 38 Keep hands and face away from smoke box when unit is in use and hot.
- 39 **ALWAYS** keep a fire extinguisher accessible while operating the oven.
- 40 **ALWAYS** store wood pellets in a dry location, away from heat-producing appliances and other fuel containers.
- 41 To disconnect, press the power button to turn the oven off, then unplug from socket when not in use and before cleaning.
- 42 Please refer to the Cleaning & Maintenance section for regular maintenance of the appliance.
- 43 Keep the oven clean and **DO NOT** allow excess grease or ash to collect inside or on the smoke box and cartridge. Doing so significantly increases the chances of a grease fire and additional smoke which can taint the flavor of the food.
- 44 To avoid personal injury and burns, allow oven to cool before cleaning, disassembly, putting in or taking off parts, and storage.
- 45 **DO NOT** clean with metal scouring pads. Pieces can break off the pad and touch electrical parts, creating a risk of electric shock.
- 46 **DO NOT** place appliance on hot surfaces, near hot gas or electric burner, in a heated oven, or on a stovetop.

SAVE THESE INSTRUCTIONS.

PARTS & ACCESSORIES

- A Assembled Main Unit (power cord not shown)
- B Accessory Frame
- C Pizza Stone
- D Pro-Heat Pan
- E Roast Rack
- F Smoke box
- G Pellet Scoop

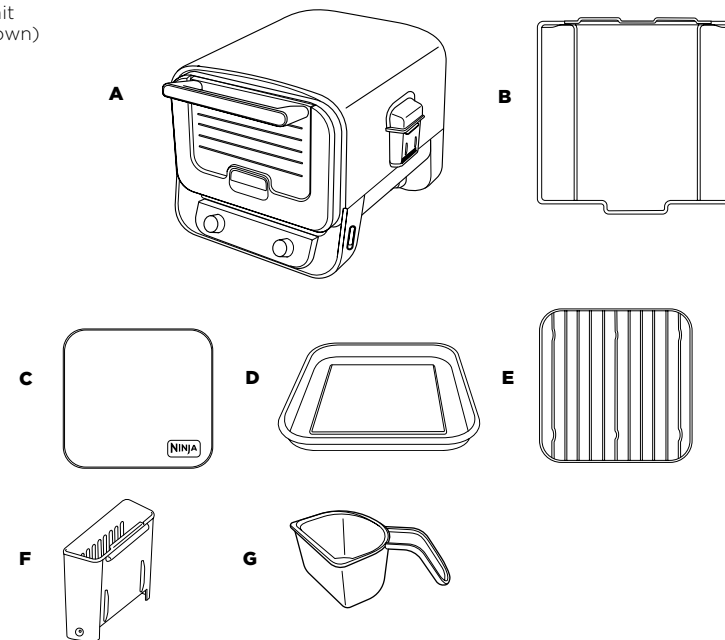

Note: The image shown here is for illustrative purposes only and may be subject to change. The actual number of accessories may vary depending on the model.

BEFORE FIRST USE

- 1 Remove all packaging material and tape from the oven.
- 2 Remove all accessories from the package and read this manual carefully. Please pay particular attention to operational instructions, warnings, and important safeguards to avoid any injury or property damage.
- 3 Rinse the Accessory Frame, Pro-Heat Pan, and Roast Rack in warm, soapy water. Rinse and dry thoroughly.
- 4 **DO NOT** use abrasive brushes or sponges on the cooking surface. Damage to the coating can occur.

NOTE: **DO NOT** get the Pizza Stone wet or put it in the dishwasher. Place it in the oven after removing all packaging.

NOTE: We recommend placing all accessories inside the oven and running it on the Bake function for 20 minutes at 700°F without adding food. This removes any residue and is not detrimental to the performance of the oven.

EXTENSION CORD

- 1 Connect to proper 3-prong grounded GFCI outlets only.
- 2 Use only outdoor extension cords marked as "SJOW" and "suitable for use with outdoor appliances." For cords up to 25 feet, use 14 gauge. For 25- to 50-foot cords, use 12 gauge. Cords longer than 50 feet are not recommended. Using the incorrect cord could lead to the cord overheating/melting and/or a drop in voltage that can increase preheat times and impact cooking performance/cook times.

BEFORE FIRST USE - CONT'D

SMOKE BOX

Installing the smoke box: To install, open by putting your finger on the side insert to hold the box open and insert the removable smoke box so it sits firmly in place.

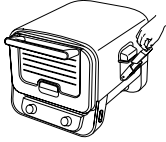

Adding Ninja Woodfire™ Pellets: Fill the pellet scoop to the top and level off to avoid spilling. While holding the smoke box lid open, pour pellets into the smoke box until filled to the top. Then, close the smoke box lid.

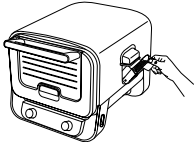

For best results, performance, and flavor, use only Ninja Woodfire Pellets.

Removing and cleaning the smoke box: To avoid burns, allow pellets to cool completely before removing from the oven and cleaning.



HOW TO INSTALL THE ACCESSORY FRAME:

- 1 Install Accessory Frame in the bottom level of the oven (top level if using the Broil function).

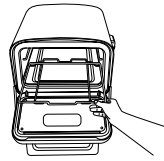

- 2 If cooking pizza, place the Pizza Stone on the Accessory Frame.

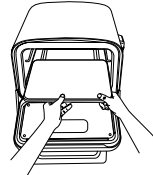

- 3 For all other functions, remove the Pizza Stone and place the Pro-Heat Pan in the Accessory Frame.

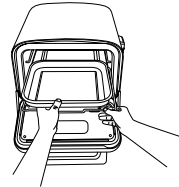

- 4 If using the Roast Rack, nest it in the Pro-Heat Pan.



GETTING TO KNOW THE NINJA WOODFIRE™ OUTDOOR OVEN

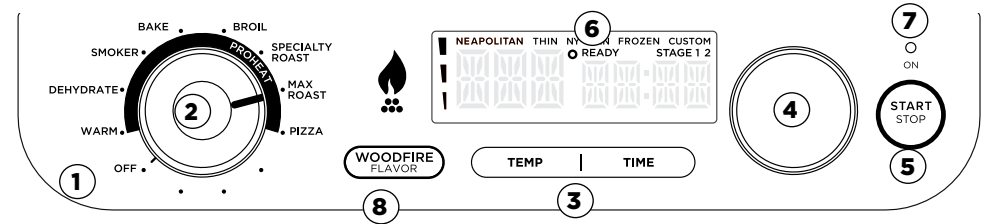

The image shown here is for illustrative purposes only and may be subject to change. The actual descriptions of control panel and their locations may vary, depending on the model.

NOTE: Functions may vary by model.

FUNCTIONS

Turn the left-hand dial to select the desired function or to turn off the oven.

WARM: Keep meals warm and ready to eat after cooking.

DEHYDRATE: Gently remove moisture for snacks like jerky and dried fruit.

SMOKER: Low and slow cooking to tenderize large cuts of meat.

BAKE: Create baked goods with crispy crusts and fluffy centers.

BROIL: Quickly melt toppings or create beautifully browned exteriors

SPECIALTY ROAST: Start high and finish low for a crisp outside and juicy inside.

MAX ROAST: Get charred, crispy, caramelized results a traditional oven can't create.

PIZZA: Make your favorite pizza styles at home from fresh to frozen

Neapolitan - Neapolitan-style pizzas have char on the outside of the thin, crispy crust and are piled high with fresh mozzarella cheese.

Thin - A thinner crust supports a smattering of thinly sliced ingredients that cook quickly.

Pan - A thicker crust and use of a deep-style pan means you can pile on your ingredients since it bakes longer than a thin crust.

New York Style - Thinner crust with lots of low-moisture mozzarella cheese piled on top. The cheese extends close to the edge of the dough, leaving about an inch exposed to handle the slice while eating.

Frozen - For best results, follow the instructions on the box.

Custom - Use your favorite style crust and add your favorite ingredients to create your own custom pizza.

OPERATING BUTTONS/DIALS/INDICATOR LIGHTS

1. OFF: When unit is not in use, ensure dial is in the OFF position.

2. LEFT-HAND DIAL: Use this dial to select desired cook function.

3. TEMP/TIME BUTTONS: Press the TEMP button, then use the right-hand dial to select desired temperature. Press the TIME button, then use the right-hand dial to select desired time.

4. RIGHT-HAND DIAL: Use this dial along with the TEMP and TIME buttons to adjust the temperature and time and to choose pizza type.

5. START/STOP BUTTON: Press START/STOP button to start or stop the current cook function.

NOTE: While not recommended, preheating can be skipped by pressing and holding the right-hand dial for 4 seconds.

6. READY: When cooking multiple pizzas, the READY indicator will illuminate, indicating the Pizza Stone is at temperature to cook the next Pizza.

7. ON: If the oven is on and not set to the OFF position, this light will illuminate, indicating the oven is still on and hot. When the oven is not in use, turn the left-hand dial to OFF.

8. WOODFIRE FLAVOR: Press to add Woodfire Flavor to food. (Cannot be used for Warm or Broil.)

The images shown here are for illustrative purposes only and may be subject to change.

USING THE NINJA WOODFIRE™ OUTDOOR OVEN

COOKING FUNCTIONS

Bake, Dehydrate, Warm (not included on all models)

- 1 Install the Accessory Frame in the bottom of the oven.

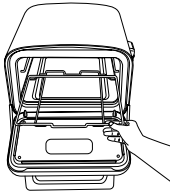

- 2 Turn the left-hand dial to select BAKE, DEHYDRATE, or WARM.
- 3  If you plan to use the **WOODFIRE FLAVOR TECHNOLOGY**, pull the smoke box open and use the pellet scoop to fill the smoke box to the top with Ninja Woodfire Pellets. **DO NOT** overflow the smoke box. Then press the **WOODFIRE FLAVOR TECHNOLOGY** button.
- 4 Press the TEMP button, then use the right-hand dial to set the temp. Press the TIME button, then use the right-hand dial to set the time.
- 5 Press START/STOP to begin preheating. Estimated preheat time is 5 to 25 minutes depending on set temperature. If using Woodfire Flavor Technology, the pellets will go through an ignition cycle (IGN), then the oven will begin preheating (PRE).

NOTE: There is no preheat time for the Warm and Dehydrate functions.

- 6 While oven is preheating, start prepping ingredients.
- 7 When the oven is preheated, ADD FOOD, PRS START will appear on the display.
- 8 Use oven mitts to pull out the frame and place pan with ingredients onto frame.
- 9 Press START/STOP to begin cooking. The timer will begin counting down.
- 10 When cook time is complete, the oven will beep and DONE will display.
- 11 Use oven mitts to remove food from the oven. Let it rest, then serve.



Smoker

- 1 Install the Accessory Frame in the bottom of the oven, then place the Pro-Heat Pan on top of it. Place the Roast Rack in the pan (optional).

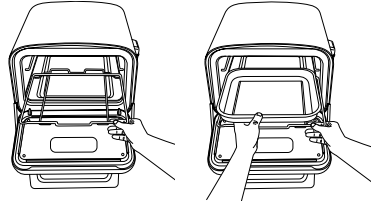

- 2 Turn the left-hand dial to select SMOKER.
- 3 Place ingredients on the Roast Rack or Pro-Heat Pan.



- 4 Pull the smoke box open and use the pellet scoop to fill the smoke box to the top with Ninja Woodfire Pellets. **DO NOT** overflow the smoke box.
- 5 Press the TEMP button, then use the right-hand dial to set the temp. Press the TIME button, then use the right-hand dial to set the time.
- 6 Press START/STOP to begin cooking. There is no preheat time for the Smoker function. The pellets will go through an ignition cycle (IGN) for 3-4 minutes, then the oven will begin cooking and the timer will begin counting down.
- 7 When cook time is complete, the oven will beep and DONE will appear on the display.
- 8 Use oven mitts to remove food from the oven. Let it rest, then serve.

Specialty Roast

- 1 Install the Accessory Frame in the bottom of the oven.

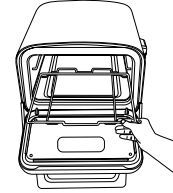

- 2 Turn the left-hand dial to select SPECIALTY ROAST.
- 3  If you plan to use the **WOODFIRE FLAVOR TECHNOLOGY**, pull the smoke box open and use the pellet scoop to fill the smoke box to the top with Ninja Woodfire Pellets. **DO NOT** overflow the smoke box. Press the **WOODFIRE FLAVOR TECHNOLOGY** button.
- 4 Stage 1 LED will illuminate; this is the high temperature setting.
- 5 Press the TEMP button, then use the right-hand dial to set the temp. Press the TIME button, then use the right-hand dial to set the time.
- 6 Push the right-hand dial and Stage 2 LED will turn on. Repeat the previous step to program Stage 2.
- 7 Press START/STOP to begin preheating. Estimated preheat time is 25 minutes depending on set temperature. If using Woodfire Flavor Technology, the pellets will go through an ignition cycle (IGN), then the oven will begin preheating (PRE).
- 8 When the oven is preheated, ADD FOOD PRS START will appear on the display.
- 9 Pull the Accessory Frame forward and place pan with ingredients onto frame. Close the door.
- 10 Press START/STOP to start timer. Stage 1 temp and time will display and timer will begin counting down. The oven will automatically switch to Stage 2 settings when Stage 1 is complete.
- 11 When cook time is complete, the oven will beep and DONE will display on the oven.
- 12 Use oven mitts to remove food from the oven. Let it rest, then serve.

Max Roast

- 1 Install the Accessory Frame in the bottom of the oven, then place the Pro-Heat Pan on top of it.

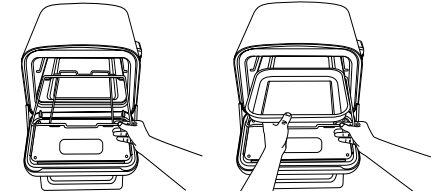

IMPORTANT: Pro-Heat Pan should be installed as it needs to preheat with the oven.

- 2 Turn the left-hand dial to select MAX ROAST.
- 3  If you plan to use the **WOODFIRE FLAVOR TECHNOLOGY**, pull the smoke box open and use the pellet scoop to fill the smoke box to the top with Ninja Woodfire Pellets. **DO NOT** overflow the smoke box. Then press the **WOODFIRE FLAVOR TECHNOLOGY** button.
- 4 Press the TEMP button, then use the right-hand dial to set the temp. Press the TIME button, then use the right-hand dial to set the time.
- 5 Press START/STOP to begin preheating.
- 6 While oven is preheating. Start prepping ingredients. Estimated preheat time is 25 minutes depending on set temperature.
- 7 When the oven is preheated, ADD FOOD PRS START will appear on the display.
- 8 Use oven mitts to pull out the frame and place ingredients on the pan.
- 9 Press START/STOP to begin cooking. The timer will begin counting down.
- 10 When cook time is complete, the oven will beep and DONE will display.

NOTE: The unit will beep and display FLIP for 30 seconds. Flipping is optional, but recommended.

- 11 Use oven mitts to remove food from the oven. Let it rest, then serve.

The images shown here are for illustrative purposes only and may be subject to change.

The images shown here are for illustrative purposes only and may be subject to change.

USING THE NINJA WOODFIRE™ OUTDOOR OVEN – CONT'D

Pizza

- 1 Install the Accessory Frame in the bottom of the oven, then place the Pizza Stone on top.

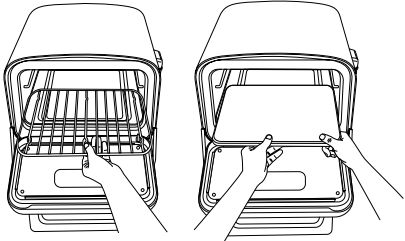

NOTE: If cooking Pan Pizza, you will need to prepare in a deep-dish pan (not included).

- 2 Turn the left-hand dial to select PIZZA.

- 3  If you plan to use the **WOODFIRE FLAVOR TECHNOLOGY**, pull the smoke box open and use the pellet scoop to fill the smoke box to the top with Ninja Woodfire Pellets. **DO NOT** overflow the smoke box. Press the **WOODFIRE FLAVOR TECHNOLOGY** button.

- 4 Use the right-hand dial to select the desired preset pizza type (Neapolitan, Thin, Pan, New York Style, Frozen, or Custom).

NOTE: Temp can only be set using MANUAL.

- 5 Press START/STOP to begin preheating. Estimated preheat time is 10–25 minutes depending on set temperature. If using Woodfire Flavor Technology, the pellets will go through an ignition cycle (IGN), then the oven will begin preheating (PRE).
- 6 Use the right-hand dial to set TIME. Setting TIME is different for PIZZA. This sets the pizza cook timer (similar to an oven timer). When time has ended, the oven will stay on for up to one hour for cooking back-to-back pizzas.
- 7 Once the oven has reached temperature, ADD FOOD PRS STRT will display. Place pizza directly on the stone.

NOTE: We recommend using the Ninja Pizza Peel, sold separately. If you do not have a pizza peel, use the cutting board or underside of a bake pan with flour to place pizza on stone.

- 8 Press START/STOP again and the timer will begin counting down.
- 9 When cook time is complete, the oven will beep and GET FOOD will appear on the display. Use pizza peel to remove pizza from oven.

NOTE: COOKING BACK-TO-BACK PIZZAS – For best results, wait until READY appears on the display. This indicates the stone is back up to temperature. Then add the next pizza.

Broil (not included on all models)

- 1 Install the Accessory Frame in top level of the oven, then place the Pro-Heat Pan on top of it. Place the Roast Rack in the pan (optional).

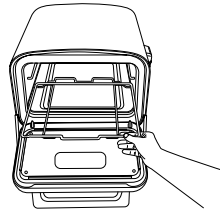

- 2 Turn the left-hand dial to select BROIL.
- 3 Press the TEMP button, then use the right-hand dial to set the temp. Press the TIME button, then use the right-hand dial to set the time.
- 4 Place ingredients on the Roast Rack or Pro-Heat Pan.
- 5 Press START/STOP to begin cooking. There is no preheat time. The oven will begin cooking and the timer will begin counting down.
- 6 When cook time is complete, the oven will beep and DONE will display.
- 7 Use oven mitts to remove food from the oven. Let it rest, then serve.

The images shown here are for illustrative purposes only and may be subject to change.

CLEANING & MAINTENANCE

CLEANING THE OVEN

- 1 The oven should be cleaned thoroughly after each use. **ALWAYS** let the appliance and accessories cool before cleaning.
- 2 Unplug the grill from power source before cleaning. Keep the door open after removing food to allow the oven to cool quicker.
- 3 Use soap and water to clean the inside of oven with a nylon brush.

CLEANING THE ACCESSORIES

Smoke box

Remove smoke box and safely discard all contents after every use.

Cleaning the smoke box after every use is not required. Use a wire brush to remove extra creosote after every 10 uses.

NOTE: DO NOT use liquid cleaning solution on the smoke box.

Pizza Stone

Allow the pizza stone to cool completely before cleaning. The pizza stone can crack or break if it comes in contact with cold water while it's hot.

- 1 Scrape lightly. **DO NOT** use a metal spatula or knife, as these can scratch the pizza stone.
- 2 Wipe any remaining debris off the stone using a soft cloth.

NOTE: DO NOT get the Pizza Stone wet.

Roast Rack/Accessory Frame

- 1 Allow the oven to cool before removing the racks. The racks are dishwasher safe.
- 2 If washing by hand, use dish soap, warm water, and the rough side of a sponge to remove any baked-on food.
- 3 Rinse the racks and towel-dry.

Pro-Heat Pan

- 1 Allow the Pro-Heat Pan to cool. **DO NOT** put the Pro-Heat Pan in the dishwasher.
- 2 Use dish soap, warm water, and the rough side of a sponge to remove any remaining discoloration. **DO NOT** use steel wool or other abrasive scrubbers as this may scratch the cookware.
- 3 Rinse the pot or pan and dry it with a dish towel.

TROUBLESHOOTING & FAQ

WARNING: To reduce the risk of shock and unintended operation, turn power off and unplug unit before troubleshooting.

- **Why does “ADD FOOD PRS STRT” appear on the control panel display?**
The oven has completed preheating, and it is now time to add the ingredients.
- **Why does “E” appear on the control panel display?**
The oven is not functioning properly. Contact a service center.
- **Should I add my ingredients before or after preheating?**
For best results, let the oven preheat before adding ingredients.
- **Why did a circuit breaker trip while using the oven?**
The oven uses 1800 watts of power, so it must be plugged into an outlet on a 15-amp circuit breaker. Using an outlet on a 10-amp breaker will cause the breaker to trip. It is also important that the oven be the only appliance plugged into an outlet when in use. To avoid tripping a breaker, make sure the oven is the only appliance plugged into an outlet on a 15-amp breaker.
- **Why is my unit not powering on?**
To turn on the oven, rotate the left-hand dial clockwise out of the OFF position. If the oven is still not powering on, make sure it is plugged in, or try a different outlet. If the oven is still not powering on, please Contact a Service Center.
- **When do I press the Woodfire Flavor button?**
Press the Woodfire Flavor button before pressing START to add smoke when using the Dehydrate, Broil, Specialty/Max Roast, Sear, and Pizza functions. Woodfire Flavor Technology is automatically enabled when using the Smoker function.
- **Can I turn off Woodfire Flavor?**
If you pressed Woodfire Flavor and already started the cooking function by pressing START, you can press the Woodfire Flavor button again to turn it off if the ignition cycle is less than 75% complete. If pellets have fully ignited and the grill has transitioned to the preheat cycle (indicated on the display screen), you cannot turn Woodfire Flavor off.
- **Can I plug the oven into an RV outlet?**
Only if the RV outlet can provide up to 15 amps of 120-volt power.
- **Can I plug the oven into a car, SUV, or truck outlet?**
Only if the car, SUV, or truck outlet can provide up to 15 amps of 120-volt power.
- **Can I use an extension cord?**
Yes, connect to a proper 3-prong grounded GFI outlet only and ensure you are using the correct recommended cord. Use only outdoor extension cords marked as “SJOW” and “suitable for use with outdoor appliances.” For cords up to 25 feet, use 14 gauge. For 25- to 50-foot cords, use 12 gauge. Cords longer than 50 feet are not recommended. Using the incorrect cord could lead to the cord overheating/melting and/or a drop in voltage that can increase preheat times and impact cooking performance/cook times.
- **Can I use the oven when it’s raining or snowing?**
Yes, but make sure you read through all safety instructions in the owner’s guide before use. Preheat times could be impacted depending on severity of weather.
- **Can I use the oven inside?**
No, this unit is for outdoor use only.
- **Can I use oils to cook in my oven at high temperatures?**
Use the recommended fats/oils sparingly and only use the “not recommended fat/oils” when called for in a Ninja recipe (refer to “Best Practices when Cooking Above 500°F for approved fats/oils included in packaging).
- **How do I avoid a fire in my oven while batch cooking at high temperatures?**
Remember to empty the fat/oil from the Pro-Heat Pan to help prevent spillover. Ensure Pro-Heat Pan is washed thoroughly before each use. This will prevent grease from burning and causing smoke.
- **How do I avoid flare-ups when I open the oven?**
When cooking at high temperatures, specifically when roasting foods, open the door slowly and at an arm’s length. Remember to empty the fat/oil from the Pro-Heat Pan to help prevent spillover. This will help prevent smoke and flare-ups.
- **What does the READY light mean?**
READY indicates the Pizza Stone is at temperature and ready to cook.
- **What does the ON light mean?**
If the unit is on and not in the OFF position this light will illuminate, indicating the unit is still on and hot. When the unit is not in use, turn the left-hand dial to OFF.
- **Can I use my own bake pan?**
Yes. Place your bake pan (or deep-dish pizza pan if you’re using the preset Pizza “Pan” setting) on the Pro-Heat Pan. **DO NOT** place any accessories not intended for the Ninja Outdoor Oven directly on the Accessory frame.

THANK YOU for purchasing the Ninja Woodfire™ Outdoor Oven

TECHNICAL SPECIFICATIONS

Voltage: 120V-, 60Hz

SharkNinja Operating LLC

Illustrations may differ from actual product. We are constantly striving to improve our products, therefore the specifications contained herein are subject to change without notice.

NINJA is a registered trademark of SharkNinja Operating LLC.

NINJA WOODFIRE is a trademark of SharkNinja Operating LLC.

This product may be covered by one or more U.S. patents. See sharkninja.com/patents for more information.

PRINTED IN MEXICO
S.C. 03-27-2024 Elbrd: A.M.
OBPN: OO100Series_IB_MP_Mv13_230418
SHNMDL: OO101_OO101RAW

814100208

