

Shark STEAM & SCRUB

Scrubbing & Sanitizing Steam Blaster Mop

OWNER'S GUIDE

814100117

IMPORTANT SAFETY INSTRUCTIONS

PLEASE READ CAREFULLY BEFORE USE • HOUSEHOLD USE ONLY

This steam mop has a polarized plug (one blade is wider than the other). As a safety feature, this plug will fit into a polarized outlet only one way. If the plug does not fit fully into the outlet, reverse the plug. If it still does not fit, contact a qualified electrician. DO NOT attempt to defeat this safety feature. It is not recommended to use an extension cord with this product.

⚠ WARNING

TO REDUCE THE RISK OF FIRE, ELECTRIC SHOCK OR INJURY:

GENERAL WARNINGS

WHEN USING YOUR SHARK® STEAM & SCRUB, BASIC SAFETY PRECAUTIONS SHOULD ALWAYS BE FOLLOWED, INCLUDING THE FOLLOWING:

- DO NOT** leave the steam mop unattended when plugged in. **ALWAYS** unplug the power cord from the electrical outlet when not in use and before servicing.
 - DO NOT** use with damaged cord or plug. If steam mop is not working as it should or has been dropped, damaged, left outdoors, or dropped into water. Incorrect reassembly or repair can cause a risk of electrical shock or injury when the steam mop is used.
 - To protect against a risk of electric shock, **DO NOT** immerse the steam mop in water or any other liquids.
 - DO NOT** handle the plug or steam mop with wet hands or operate it without wearing shoes.
 - DO NOT** pull or carry by cord, use cord as a handle, close a door on cord, or pull cord around sharp edges or corners. **DO NOT** run steam mop over cord. Keep cord away from heated surfaces.
 - DO NOT** unplug by pulling on power cord. To unplug, grasp the plug, not the power cord. **DO NOT** use extension cords or outlets with inadequate current-carrying capacity.
 - Unplug before servicing.
 - ALWAYS** make sure the steam mop is UNPLUGGED when not in use.
 - NEVER** fill the steam mop or attach the mop head when the steam mop is plugged into an electrical outlet. Unplug from the electrical outlet and allow to cool before you fill the mop, or attach or remove the head.
 - When cleaning the exterior of the steam mop, unplug the power cord from the electrical outlet and clean the steam mop with a dry or damp cloth. **DO NOT** pour water or use alcohol, benzene, or paint thinner on the steam mop.
 - To avoid circuit overload, **DO NOT** operate another appliance on the same socket (circuit) as the steam mop.
 - To avoid scalding injuries, **ALWAYS** unplug and allow the steam mop to cool before removing or changing mop heads, accessories, or Dirt Grip® pads.
- DO NOT** put hands or feet under the steam mop. It gets very hot.
 - Use **ONLY** on flat, horizontal surfaces. **DO NOT** use on walls, counters, or windows.
 - DO NOT** use on leather, wax-polished furniture, synthetic fabrics, velvet, or other delicate, steam-sensitive materials.
 - DO NOT** add cleaning solutions, scented perfumes, oils, or any other chemicals to the water used in the steam mop as this may damage it or make it unsafe for use. If you live in a hard-water area, we recommend using distilled water in your steam mop.
 - NEVER** leave any Dirt Grip® pads in one spot while using or storing for an extended period, as this may damage your surfaces.
 - You can release the Dirt Grip® pads after you have unplugged the steam mop and allowed it to cool.
 - Extreme caution should be exercised when using the steam mop to clean stairs.
 - NEVER** use steam mop without the Dirt Grip® pads attached.
 - Keep your work area well lit.
 - Store steam mop indoors in a cool, dry place.
 - Keep hair, loose clothing, fingers, and all parts of body away from openings and moving parts.
 - DO NOT** carry the steam mop while in use.
 - The steam emitted from the steam mop is very hot and may cause scalding. Please use caution when using the steam mop.
 - DO NOT** use on unsealed wood or unglazed ceramic floors. On surfaces that have been treated with wax and on some unwaxed floors, the sheen may be removed by the heat and steam action.
 - ALWAYS** test an isolated area of the surface to be cleaned before proceeding. We also recommend that you check the use and care instructions from the floor manufacturer.
 - DO NOT** scrub any one area for an extended period.
 - DO NOT** use the steam mop without attaching the Dirt Grip® pads and adding water to the water tank. When you use the steam mop for the first time, it might take longer than the normal 30 seconds to start steaming.
 - DO NOT** use on unsealed wood or unglazed ceramic floors. On surfaces that have been treated with wax and on some unwaxed floors, the sheen may be removed by the heat and steam action. Test an isolated area of the surface to be cleaned before proceeding. Check the use and care instructions from the floor manufacturer.
 - To prolong the life of your steam mop, we recommend using distilled water. Add **ONLY** water to the tank. Chemicals or cleaning solutions (including vinegar) may damage the steam mop and could be unsafe for you and your family.
 - The liquid or steam must not be directed towards equipment containing electrical components, such as the interior of ovens.

SAVE THESE INSTRUCTIONS

TECHNICAL SPECIFICATIONS:

Voltage: 120V, 60 Hz
Water Capacity: _____ 320 ml (10.8 oz.)

GETTING STARTED

When assembling your steam mop, there may be a little water in or around the water tank. This is because we test all our steam mops before you buy them, so you get a quality Shark® Steam & Scrub steam mop.

• Accessories may vary depending on the model.



The image shown here is for illustrative purposes only and may be subject to change.

ASSEMBLING YOUR STEAM & SCRUB

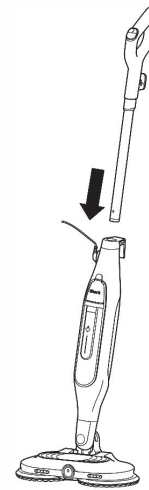

fig. 1

STEAM MOP ASSEMBLY

- Insert the mop handle into the steam mop body until it clicks into place. (fig. 1)
- To attach the Dirt Grip Soft Scrub Pads, place **BOTH** pads flat on the floor with the plastic rings facing up. Align the indent on the rotating discs on the bottom of the mop head with the plastic rings on the pads, then gently lower the mop head onto the pads, pressing until the pads are secured. (fig. 2)
- Unplug the steam mop before refilling the water tank. To open the water tank, pull the lid down. (fig. 3)
- Use a filling flask to pour distilled water into the tank (fig. 4). Make sure not to exceed the Max Fill line. When finished, close the tank lid firmly. Add **ONLY** water to the tank. Chemicals or cleaning solutions (vinegar) may damage the steam mop and could be unsafe for you and your family.

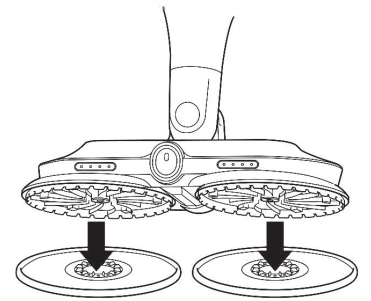

fig. 2



fig. 3

Filling flask not included.



fig. 4

USING YOUR STEAM & SCRUB

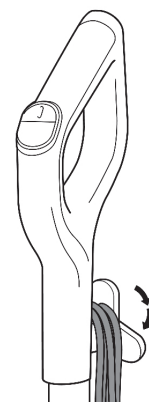

fig. 5



fig. 6

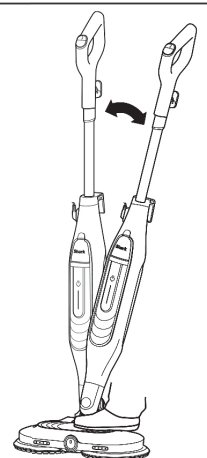





fig. 7

- NOTE:** To prolong the life of your steam mop, we recommend using distilled water.
- NOTE:** Sweep or vacuum your floors prior to cleaning with your steam mop.
- Make sure both pads are properly installed before using.
 - Twist the quick-release cord holder to unwrap the power cord completely (fig. 5). Plug into an electrical outlet.
 - When it's first plugged in, the unit will be in Standby mode. The 3 settings will blink to indicate Standby mode.
 - To select the steam mode (fig. 6), press the mode button. Once the mode is selected, tilt the handle down to activate the spinning pads (fig. 7).
- TIP:** If the handle is not reclined, the mode selection may time out and pads will not spin.
- TIP:** When cleaning near baseboards, edges, or furniture, you may feel a slight pull from the unit making contact with these surfaces. This is normal and not a cause for concern.

- Mop with a forward and backward motion.
 - When finished mopping, press the mode button until you've reached Standby mode. The settings lights will blink, indicating that the unit is in Standby mode. Once in Standby mode, lift the handle to bring the steam mop back to the upright position and unplug the unit.
 - When the pads have cooled completely, remove them by pulling them off the discs.
 - When the water tank is empty, the unit will stop producing steam. Make sure the unit is unplugged before refilling the water tank.
- NOTE:** Please wait 2 to 3 minutes for the steam mop to cool off before removing the Dirt Grip® pads. **NEVER** leave the steam mop with damp or wet Dirt Grip pads on any floor for an extended period.

INTELLIGENT STEAM CONTROL*

The **Shark® Steam & Scrub steam mop** has 3 unique Intelligent Steam Control settings so you can select the ideal amount of steam to use for each cleaning task. In **NORMAL** mode, the pads will spin faster and more steam will be produced than in **LIGHT** mode. In **DEEP** mode, the pads will spin the fastest and the maximum amount of steam will be produced. See below for tips on when to use each setting.

| SETTING | IDEAL FOR THESE SEALED SURFACES | RECOMMENDED USAGE |
|---|---------------------------------|--|
|  LIGHT | Laminate Hardwood Vinyl | Cleaning delicate surfaces Light cleaning and dusting Loosening and lifting light dirt |
|  NORMAL | Marble Tile Stone | Basic, everyday cleaning Cleaning large areas Cleaning moderate and heavy traffic areas |
|  DEEP | Marble Tile Stone | Reaching hard-to-clean surfaces Tough cleaning and removing stuck-on messes and stains Deep cleaning heavy traffic areas Cutting through heavy dirt and grime Sanitizing* floors |

STEAM BLASTER*:

- To target tough messes with an extra burst of cleaning power, move the front of the nozzle 2 to 4 inches from the mess (**fig. 8**), then press and hold the Steam Blaster button as needed. (Hold longer for the toughest messes.)
- Before scrubbing, wait 5 seconds to let the steam blast penetrate the mess.

Tip: For more difficult messes, allow 20 seconds or more.

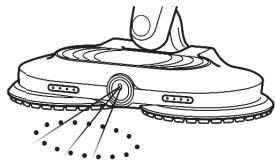

fig. 8

TO SANITIZE*:

- Attach clean Dirt Grip® Soft Scrub Pads to the scrubbing mop head.
- Plug in the unit, tilt the mop handle down, and press the mode button to select the **DEEP** setting. The pads will then start spinning.
- Wait 30 seconds for the unit to begin producing steam.
- Start mopping with a forward and backward motion on an appropriate sealed hard floor surface. After three minutes, your unit will be ready to sanitize.
- Using a forward and backward motion, move the mop head slowly and evenly over the area to be sanitized while applying continuous downward pressure. Slowly repeat at least 15 times.

*Sanitization studies were conducted under controlled test conditions. Household conditions and results may vary. With mop head in DEEP mode.

CARING FOR YOUR STEAM & SCRUB

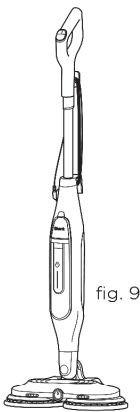

fig. 9

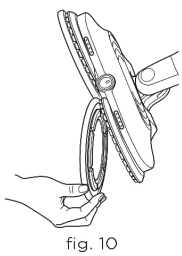

fig. 10

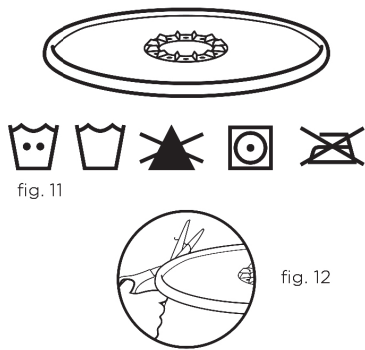

fig. 11

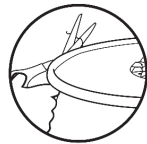

fig. 12

DIRT GRIP® SOFT SCRUB PADS CARE INSTRUCTIONS

Care

Machine-wash the Dirt Grip Soft Scrub Pads separately with warm water using liquid detergent. Do not clean pads in a dishwasher, as some detergents may cause the pads to leave streak marks on the floor.

NEVER USE BLEACH, POWDERED DETERGENT, OR FABRIC SOFTENERS as they may damage the Dirt Grip Soft Scrub Pads or leave a coating that will reduce their cleaning performance and absorbency. Dirt Grip Soft Scrub Pads should be line-dried or tumble-dried on a low setting, as this will extend the life of the microfiber fabric (**fig. 11**).

Loose fibers can indicate wearing of the microfiber fabric. **DO NOT** pull the loose fibers, as this can cause the weave to come undone. Simply trim the loose fibers with scissors (**fig. 12**).

Replacement Dirt Grip Soft Scrub Pads

For best cleaning results, we recommend replacing the Dirt Grip Soft Scrub Pads every 3 to 4 months following normal use. As with any fabric, dirt particles, grease, friction, and repeated washing can cause the fibers to break down, and you may notice an increase in the effort needed to push or pull the mop.

- Accessory type and quantity may vary depending on the model.

- The image shown here is for illustrative purposes only and may be subject to change.

*Sanitization studies were conducted under controlled test conditions. Household conditions and results may vary. With mop head in DEEP mode.

PLEASE READ CAREFULLY AND KEEP FOR FUTURE REFERENCE.

SharkNinja Operating LLC

Illustrations may differ from actual product. We are constantly striving to improve our products, therefore the specifications contained herein are subject to change without notice.

This product may be covered by one or more U.S. patents. See sharkninja.com/patents for more information.



8 1 4 1 0 0 1 1 7



PRINTED IN MEXICO Elbrd: J.E. TAB
OBPN: S7201_Series_IB_MP_Mv5
SC: 07-12-2023 SHNMDL: S7201QNV_B
Add: S7201QGN / S7201QRG

TROUBLESHOOTING

| PROBLEM | POSSIBLE REASONS & SOLUTIONS |
|--|--|
| The steam mop isn't producing any steam. | The steam mop should be securely plugged into an electrical outlet. Check your fuse or circuit breaker or try a different outlet. Make sure the water tank is full, the unit is plugged in, and the mode button is illuminated. If the settings lights are off, try a different electrical outlet. If the settings lights are blinking, press the mode button to select a steam setting. If the settings lights are illuminated steadily, wait 30 seconds for the unit to warm up. If after following the above steps the steam mop still does not produce any steam, contact a service center. |
| The steam mop is producing intermittent steam. | This is normal. For more consistent steam, select the NORMAL setting. Also make sure the water tank is full. |
| I can't select a steam setting. | Make sure the steam mop is plugged in and the settings lights are flashing. If your steam mop is producing steam but the settings lights are off, contact a service center. |
| Floors are cloudy, streaky, or spotty after steaming. | The Dirt Grip® Soft Scrub Pads might be dirty. Install a clean set of pads. If you washed the Dirt Grip Soft Scrub Pads with powdered detergent, then they could be damaged and require replacement. Due to accumulated soap or grease residue, the floor may require several cleanings with the steam mop. A more stubborn case may require you to rinse the floor with a mix of one part vinegar and two parts water* (but DO NOT put any cleaning solution into the steam mop's water tank). *Please consult your flooring manufacturer's care and maintenance instructions before applying any cleaning products or solutions. |
| It's hard to push or pull the mop. | The mop might be hard to push or pull if the Dirt Grip Soft Scrub Pads aren't wet enough. It should get easier to move the mop across the floor after it's been running for a few minutes. Overly dirty pads could also make it harder to push or pull the mop. We recommend using clean pads. |
| Rotating discs are not turning or are wobbling. | The steam mop may be in the upright position. Tilt the handle down to use the mop. The Dirt Grip Soft Scrub Pads may not be centered. Turn the power OFF, unplug the steam mop, wait for a few moments to allow the pads to cool, then reinstall the Dirt Grip Soft Scrub Pads. |
| The steam mop is vibrating or wobbling. | The Dirt Grip Soft Scrub Pads are not centered on the rotating discs. Turn the power OFF and unplug the unit, and wait for the pads to cool. Follow the instructions in the Assembling Your Steam & Scrub section to reinstall the pads. |
| The steam mop turns off on its own. | If your steam mop shuts off while in use, it likely needs to cool down. Perform the following steps before you restart cleaning: 1. Turn the steam mop off, unplug it, and remove pads. 2. Allow the unit to cool for a minimum of 30 minutes. 3. Reinstall the pads. Plug in the steam mop, select a steam mode, and begin cleaning. |

FAQ

| QUESTION | ANSWER |
|---|--|
| Can I use the steam mop on carpets? | No, the steam mop is not designed for carpet cleaning. |
| What surfaces can I use the steam mop on? | The steam mop is designed for use on all sealed hard floor surfaces. We recommend that you first test an isolated area of the floor surface to be cleaned as well as review the use and care instructions from your floor manufacturer. ▲ WARNING: DO NOT use on leather, wax-polished furniture, synthetic fabrics, velvet, or other delicate, steam-sensitive materials. NOTE: On surfaces treated with wax and on some unwaxed floors, the sheen may be removed by the heat or steam action of the unit. Test an isolated area of flooring first to see if sheen is affected. |
| Can I put something other than water in the water tank of the steam mop? | DO NOT add cleaning solutions, vinegar, scented perfumes, oils, or any other chemicals to the water used in this appliance, as this may damage the unit or make it unsafe for use. We recommend using distilled water in your steam mop. |

REFURBISHED PRODUCT LIMITED NINETY DAYS WARRANTY

The **Refurbished Product Service Center** offers the following WARRANTY to the ORIGINAL purchaser of a product which we have refurbished.

This product that has been refurbished is warranted against any electronic or mechanical defects for a period of NINETY DAYS from the date of the original purchase by the consumer. Since this unit was sold as a refurbished item, the warranty does not apply to any cosmetic appearance items such as scratches. Should a defect occur, the **Refurbished Product Service Center** will repair or, at its option, replace defective unit/parts with new or rebuilt materials without charge for either parts or labor. Replacement unit/parts will be warranted for the remaining portion of the original warranty period.

This warranty does not cover installation or damage from accident, misuse, abuse, improper wiring, incorrect voltage, operating the unit against the instructions in the owner's manual or any product which has been opened, altered, or tampered with.

This warranty does not cover costs for removal and or installation of the unit for repair. Under no circumstances shall the service center be liable for any special, incidental or consequential damages or for any other expenses incurred by reason of use or sale of this product. This warranty is in lieu of any other warranties expressed or implied warranty of merchantability of fitness for particular use or otherwise.

This warranty gives the consumer specific legal rights and they may also have other rights which vary from State to State. Some States do not follow the exclusion or limitation of incidental or consequential damages, hence the above exclusion and limitations may not apply.

Refurbished Product Service Center
13225 Marquardt Avenue Santa Fe Springs, CA 90670.

WARRANTY REPAIR INFORMATION

If you need service on your unit and this product requires repair during the 90 days warranty period; please go to www.ConsumerServiceRefurbish.com or call the **Refurbished Product Service Center** at 562-946-3531 to obtain the required return authorization (RA) number. Pack the unit properly (the original carton is ideal for this purpose) along with a copy of your purchase receipt and a letter describing the problem. Send the unit freight prepaid and insured to:

Refurbished Product Service Center,
Att: Customer Service Department 13225 Marquardt Avenue Santa Fe Springs, CA 90670

Your unit will be promptly repaired and returned to you.

We will refuse to accept delivery of the returned unit unless the assigned RA number appears on the outside of the shipping carton.

Owner's Information
(Keep for your permanent records)

NAME: _____

ADDRESS: _____

CITY: _____ STATE: _____ ZIP CODE: _____

PHONE: _____ E-MAIL: _____

MODEL: _____ SERIAL NO.: _____