

Shark ROTATOR®

NV500 Series INSTRUCTIONS

804109291

PLEASE READ CAREFULLY AND KEEP FOR FUTURE REFERENCE.

This Owner's Guide is desing to help you get a complete unertanding of your new Shark Rotator Professional Lift-Away.

IMPORTANT SAFETY INSTRUCTIONS

For Household Use Only

WHEN USING YOUR SHARK® NAVIGATOR™ VACUUM, BASIC SAFETY PRECAUTIONS SHOULD ALWAYS BE FOLLOWED, INCLUDING THE FOLLOWING:

READ ALL INSTRUCTIONS BEFORE USING YOUR SHARK® NAVIGATOR™ VACUUM.

POLARIZED PLUG:

This appliance has a polarized plug (one blade is wider than the other). As a safety feature, this plug will fit into a polarized outlet only one way. **Do not force into the outlet or try to modify the plug to fit.**

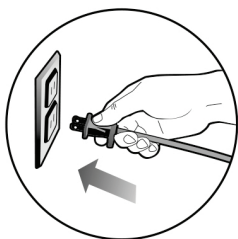

⚠ WARNING:

TO REDUCE THE RISK OF ELECTRIC SHOCK OR INJURY DO NOT USE OUTDOORS OR ON WET SURFACES.

GENERAL ELECTRICAL SAFETY:

1. Unplug from electrical outlet when not in use and before servicing.
2. **DO NOT** use vacuum with a damaged cord or plug.
3. **DO NOT** pull or carry vacuum by the cord.
4. **DO NOT** unplug by pulling on cord; to unplug grasp the plug, not the cord.
5. **DO NOT** handle plug or vacuum cleaner with wet hands.
6. **DO NOT** run the vacuum over the power cord
7. **DO NOT** close a door on the cord.
8. **DO NOT** pull cord around sharp edges or corners.
9. **DO NOT** leave appliance when plugged in.
10. Keep power cord away from heated surfaces.
11. Turn off all controls before plugging or unplugging vacuum cleaner.

GENERAL USE:

12. Use only as described in this manual.
13. **DO NOT** put any objects into openings.
14. Keep your work area well lit.
15. Keep the vacuum moving over the carpet surface at all times to avoid damaging the carpet fibers.
16. **DO NOT** place vacuum on unstable surfaces such as chairs or tables.
17. **DO NOT** allow young children to operate the vacuum or use as a toy.

18. Close attention is necessary when used by or near children.
19. **DO NOT** use vacuum cleaner if the appliance is not working as it should, has a damaged plug or cord, if the unit has been dropped, damaged, left outdoors or submerged in water. Call a Service Center.

- GENERAL CLEANING:**
20. **DO NOT** run the vacuum over large-sized objects.
 21. **DO NOT** pick up hard or sharp objects such as glass, nails, screws or coins that could damage the vacuum cleaner.
 22. **DO NOT** pick up smoking or burning objects such as hot coals, cigarette butts or matches.
 23. **DO NOT** pick up flammable or combustible materials such as lighter fluid, gasoline, kerosene or use in areas where they may be present.
 24. **DO NOT** pick up toxic solutions such as chlorine bleach, ammonia or drain cleaner.
 25. **DO NOT** use in an enclosed space where vapors are present from paint, paint thinner, moth-proofing substances, flammable dust or other explosive or toxic materials.
 26. **DO NOT** vacuum up any liquids.
 27. **DO NOT** immerse vacuum cleaner in water or other liquids.
 28. **DO NOT** use outdoors or on wet surfaces; use only on dry surfaces.
 29. Use extra care when cleaning on stairs.
 30. Before turning on the vacuum:
 - Make sure that dust cup, and all filters are in place after routine maintenance.
 - Make sure that all components and filters are thoroughly dry after routine cleaning.
 - Only use filters and accessories provided [Failure to do so will void the warranty]

HOSE ATTACHMENTS:

31. **DO NOT** put any object into openings. Do not use with any opening blocked. Keep free of lint, hair and anything that may reduce airflow.
32. **DO NOT** use if air flow is restricted; if the air paths, the hose or the extension tube become blocked, turn the vacuum cleaner off. Remove all obstructions before you turn on the unit again.
33. Keep the end of the hose, wands and other openings away from face, body and loose clothing.
34. Keep rotating brush and suction openings away from hair, face, fingers, uncovered feet or loose clothing.
35. Only use manufacturer's recommended attachments.

SAVE THESE INSTRUCTIONS

Assembly

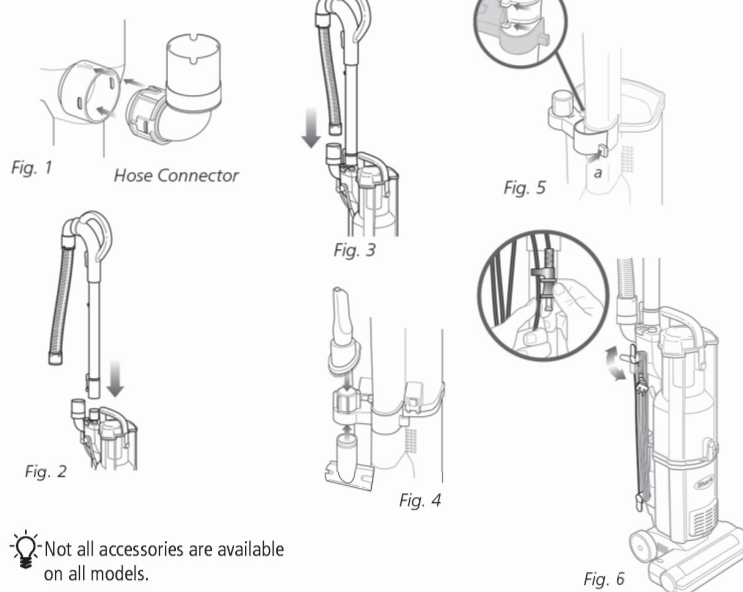

⚠ Not all accessories are available on all models.

YOUR SHARK® NAVIGATOR™ IS EASY TO ASSEMBLE:

- 1 Place your vacuum body upright on a level surface.
- 2 Insert the hose connector into the opening on the back of the vacuum body. (Fig. 1) **NOTE:** Once the hose connector has been inserted, it cannot be removed.
- 3 Insert the handle with the extension wand into the top of the vacuum until secure. (Fig. 2)
- 4 Insert the stretch hose into the hose connector on the back of the unit. Make sure that it snaps in place. (Fig. 3)
- 5 Store your on-board tools onto the accessory holder located on the back of the unit. (Fig. 4) **NOTE:** The accessory holder is removable. In order to remove or attach the accessory holder, you must remove the dust cup first. To remove the accessory holder, just hold the tab (a), rotate left and pull out. To replace, align the pins into the hinges (b) on the vacuum. Rotate it fully to secure. (Fig. 5)
- 6 When storing your vacuum, wind the power cord around the two cord holders and secure with cord clip. (Fig. 6)

- 7 There is a Quick Cord Release on the top cord holder. Simply turn to the left or right to release the power cord. To store the unit, the cord holder should be in the upright position.

⚠ **IMPORTANT:** For suction to reach the power nozzle, the extension wand and stretch hose must be attached securely on the vacuum body.

- 8 **TO CARRY THE VACUUM:** With the unit in the standing position, lift by the Dust Cup Handle (carry handle).

⚠ **CAUTION:** When lifting or carrying, **DO NOT** press Dust Cup release button (a).

Using the Vacuum

⚠ The height of your power nozzle has been optimized for easy pushing and superior cleaning on all floor types. There is no need to make any height adjustments as you transition to different floor & carpet types.

⚠ **Always hold the vacuum when using the hose to clean so that it does not tip over.**

- DO NOT** pull vacuum cleaner around by the hose.
- DO NOT** over-extend the hose.

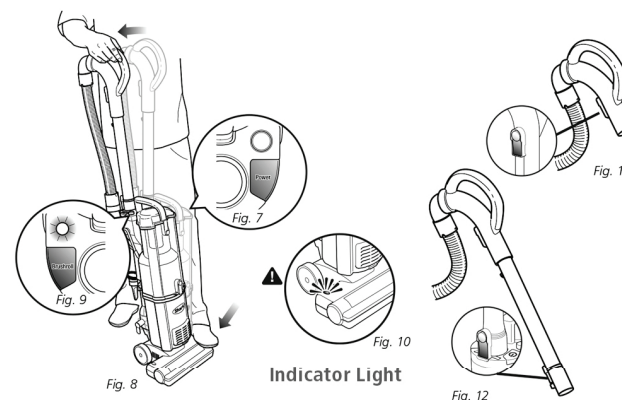

Your *Shark® Navigator™* can be used to clean all surface types.

- 1 Plug in the vacuum.
- 2 Push the "Power" button.
- 3 Place your foot on the power nozzle and pull the handle back towards you. (Fig. 8) **NOTE:** This vacuum has a separate "Brushroll" button on the top of the vacuum. (Fig. 9)
- 4 **CLEAN CARPETS:** Engage the brushroll by pushing the "Brushroll" button to the "ON" position. The brushroll light will turn green. (Fig. 9)

⚠ **IMPORTANT:** To protect your carpets, the brushroll will only turn on when you have pulled the handle back towards you and released the power nozzle.

⚠ **IMPORTANT:** The brushroll indicator light on the power nozzle will illuminate solid red if there is a blockage. (Fig. 10) This feature is designed to protect your Lifetime Belt that powers your brushroll. **See Checking for Blockages**

5 CLEAN BARE FLOORS:

For cleaning bare floors or to clean with the hose, push the "Brushroll" button to the "OFF" position for suction only. The brushroll will not spin in this mode.

6 CLEAN ABOVE-FLOORS WITH HOSE:

You can attach the accessories onto the handle or onto the extension wand for a longer reach.

- a Stand the vacuum into upright position.
- b To remove the handle only, press the handle release button. (Fig. 11)
- c To remove the handle with the extension wand, press the extension wand release button on the back of the vacuum. (Fig. 12)
- d Push the selected tool into the end of the handle or handle with extension wand for longer reach and begin cleaning.

Getting Started

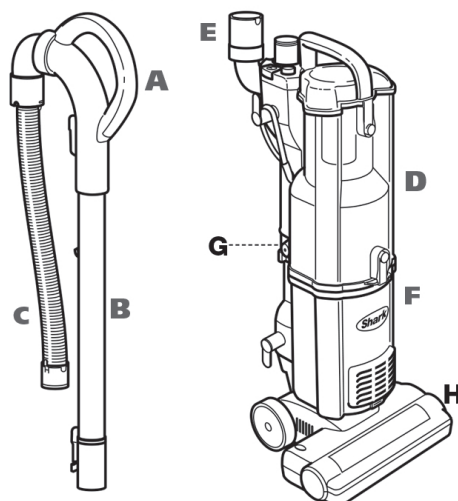

FIRST THING'S FIRST, YOU NEED TO KNOW WHAT'S IN THE BOX YOU JUST OPENED:

- | | |
|-------------------------|---------------------------|
| A Handle | E Hose Connector |
| B Extension Wand | F Vacuum Body |
| C Stretch Hose | G Accessory Holder |
| D Dust Cup | H Power Nozzle |

Emptying the Dust Cup Assembly

⚠ For best results empty the Dust Cup Assembly after each use; or as needed during prolonged usage. or when it reaches the **MAX** fill line.

DO NOT OVERFILL. Turn vacuum off before emptying.

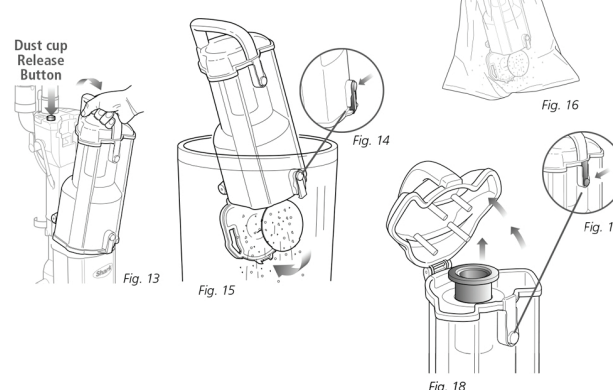

Note: Your Quick Start Guide shows the accessories that are included with your model. *Accessories may vary depending on model. The image shown here is for illustrative purposes only and may be subject to change.

TO EMPTY THE DUST CUP ASSEMBLY:

- 1 Press the Dust Cup release button (🔑) and remove the dust cup from the vacuum. (Fig. 13)
- 2 Grip carry handle and press the bottom Dust Cup Door release button. (Fig. 14)
- 3 **Option A:** for Quick Empty: Insert Dust Cup Assembly deep inside trash receptacle to contain dust and debris. (Fig. 15)
Press the bottom Dust Cup Door release button; tap container gently to dislodge and release dust and debris.
Close the bottom door until it snaps in place.

⚠️ Important: If the Dust Cup Door does not swing open freely after pressing the release button, push the door open using the bottom door tabs.

- 4 **Option B:** For Allergy Sufferers: Wrap a trash bag around the Dust Cup Assembly leaving space at the bottom for the door to swing open. (Fig. 16)

Locate the Dust Cup Door release button within the trash bag and press to release as you shake the dust cup to empty dust and debris.

Close the bottom door until it snaps in place.

⚠️ Note: Option B can also be performed outside of the home to further minimize releasing dust back into the air. Carry just the Dust Cup Assembly and trash bag outside.

⚠️ Note: It may become necessary to occasionally clean the metal screen inside the dust cup. To clean, press the top dust cup release button (Fig. 17), pull out the metal screen and remove any excess dirt. Then replace the metal screen inside the dust cup and close the top lid. (Fig. 18)

Proper Care of Your Shark® Upright Vacuum

COMPONENT	MAINTENANCE SCHEDULE
1 Dust Cup	Empty each time you vacuum.
2 Pre-Motor Foam Filter	Rinse and air dry every month under normal use.
3 Pre-Motor Felt Filter	Rinse and air dry every month under normal use.
4 Post-Motor Filter	Clean once every 12 months under normal use.

⚠️ DO NOT put the filters in the washing machine or dishwasher.

NOTE: The material in the filter will discolor over time. This is NORMAL and will not affect the performance of the filter.

⚠️ IMPORTANT: Loss of Suction may occur if foam filters are not cleaned every month. Rinse and allow to air dry completely. Foam filters may appear dirty after use - this is normal.

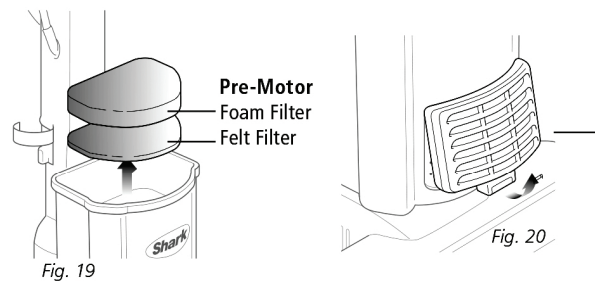

CLEANING THE PRE-MOTOR FILTERS

- 1 Remove the dust cup.
- 2 Pull the 2 filters out from the top of the motor base. (Fig. 19)
- 3 Rinse the filters thoroughly in lukewarm water until the water runs clear.
- 4 Squeeze out excess water and let air-dry for at least 24 hours before replacing. Do not use a hair dryer or other heating methods to dry.
- 5 Place the felt filter in first, then the foam filter.
- 6 Replace the dust cup.

CLEANING THE POST-MOTOR FILTER

- 1 Remove the filter cover from the front of the vacuum by pulling up on the tab and pulling the cover away from the vacuum. (Fig. 20)
- 2 Remove the filter from the frame and wash the filter under the tap using lukewarm water.
- 3 Allow the filter to air dry for 24 hours. Do not use a hair dryer or other heating methods to dry.
- 4 Once the filter is dry, replace it back into the vacuum.
- 5 Replace the cover by inserting the two tabs into the holes at the top and then swinging the cover down until it clicks into place.

NOTE: Filters may appear dirty but frequent cleaning of these is not necessary. See maintenance schedule above.

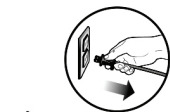

⚠️ CAUTION: Unplug the vacuum while cleaning filters; failure to do so might result in electric shock.

Maintenance

Resetting the Motor Thermostat

Your **Shark® Navigator™** is equipped with a protective Motor Thermostat. If the motor should overheat, the thermostat shuts off the power.

TO RESET THE MOTOR THERMOSTAT:

- 1 Press the Power Button (⏻) to turn the unit "Off".
- 2 Unplug the vacuum.
- 3 Check for clogged hose or filter; unclog hose and replace filter. Refer to **Checking for Blockages**

Wait 45 minutes for vacuum to cool; then plug in the vacuum.

Press the Power Switch (⏻) to start the vacuum.

Checking for Blockages

Blockages may cause your vacuum to overheat and shut down. If this occurs, clear the blockages, then follow the instructions for **Resetting the Motor Thermostat**

⚠️ IMPORTANT: Never insert sharp objects into any opening to clear an obstruction. Damages caused while clearing or attempting to clear blockages are not covered under your product's limited warranty.

Reassemble all parts securely before operating vacuum.

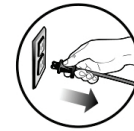

Unplug the vacuum before checking for blockages.

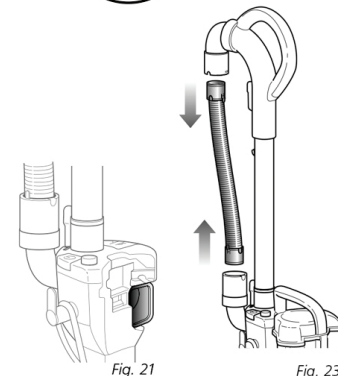

Fig. 21

Fig. 23

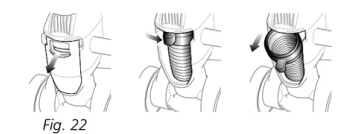
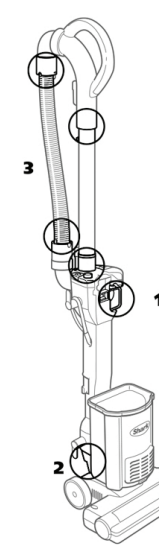

Fig. 22



1 DUST CUP AIR DUCT:

Stand vacuum upright.
Remove Dust Cup Assembly and empty Dust Cup if necessary.
Check Air Duct behind Dust Cup for clogs; clear before replacing Dust Cup Assembly. (Fig. 21)

2 HOSE INTAKE OPENING:

Hold the top of the hose access door and pull firmly to remove. Slide the knob to the center and pull out the hose. (Fig. 22)
Remove any obstructions and push the hose back in.
Slide the knob to the left and snap the hose access door shut.

3 HOSE:

Disconnect the Stretch Hose by gently pressing the tabs together and pulling away from the hose connector.

Remove hose from both the unit and handle ends. (Fig. 23)

Inspect the length of the hose and remove any obstructions.

The image shown here is for illustrative purposes only and may be subject to change.

REFURBISHED PRODUCT LIMITED NINETY DAYS WARRANTY

The **Refurbished Product Service Center** offers the following WARRANTY to the ORIGINAL purchaser of a product which we have refurbished.

This product that has been refurbished is warranted against any electronic or mechanical defects for a period of NINETY DAYS from the date of the original purchase by the consumer. Since this unit was sold as a refurbished item, the warranty does not apply to any cosmetic appearance items such as scratches. Should a defect occur, the **Refurbished Product Service Center** will repair or, at its option, replace defective unit/parts with new or rebuilt materials without charge for either parts or labor. Replacement unit/parts will be warranted for the remaining portion of the original warranty period.

This warranty does not cover installation or damage from accident, misuse, abuse, improper wiring, incorrect voltage, operating the unit against the instructions in the owner's manual or any product which has been opened, altered, or tampered with.

This warranty does not cover costs for removal and or installation of the unit for repair. Under no circumstances shall the service center be liable for any special, incidental or consequential damages or for any other expenses incurred by reason of use or sale of this product. This warranty is in lieu of any other warranties expressed or implied warranty of merchantability of fitness for particular use or otherwise.

This warranty gives the consumer specific legal rights and they may also have other rights which vary from State to State. Some States do not follow the exclusion or limitation of incidental or consequential damages, hence the above exclusion and limitations may not apply.

Refurbished Product Service Center
13225 Marquardt Avenue Santa Fe Springs, CA 90670.

WARRANTY REPAIR INFORMATION

If you need service on your unit and this product requires repair during the 90 days warranty period; please go to www.ConsumerServiceRefurbish.com or call the **Refurbished Product Service Center** at 562-946-3531 to obtain the required return authorization (RA) number. Pack the unit properly (the original carton is ideal for this purpose) along with a copy of your purchase receipt and a letter describing the problem. Send the unit freight prepaid and insured to:

Refurbished Product Service Center,
Att: Customer Service Department 13225 Marquardt Avenue Santa Fe Springs, CA 90670

Your unit will be promptly repaired and returned to you. We will refuse to accept delivery of the returned unit unless the assigned RA number appears on the outside of the shipping carton.

Owner's Information
(Keep for your permanent records)

NAME: _____
ADDRESS: _____
CITY: _____ STATE: _____ ZIP CODE: _____
PHONE: _____ E-MAIL: _____
MODEL: _____ SERIAL NO.: _____

Troubleshooting

⚠️ WARNING: To reduce the risk of electric shock, the power cord must be disconnected before performing maintenance/troubleshooting checks.

PROBLEM	POSSIBLE REASONS & SOLUTIONS
Vacuum will not run.	Check to see if the vacuum is plugged in properly. Check the circuit breaker/fuse. Check the On/Off button.
Vacuum is not picking up dirt.	Check filters to see if they need cleaning. Follow instructions for rinsing and drying the filters before re-inserting back into the vacuum. (See "Maintenance" sections for instructions.) Dust cup may be full; empty dust cup.
Airflow is restricted. No suction or light suction.	Check hose and hose connections for blockages; clear blockages if required. If dust cup is empty, and attachment inlets are clear, check for other blockages. (See "Checking for Blockages" for instructions.)
Brush roll does not turn on.	Press the "Brushroll" button to the "ON" position. The brushroll light near this button will illuminate green when "ON". Place your foot on the floor brush and pull the handle back to engage the brushroll. If the red light on the power nozzle is illuminated, see the section on Checking for Blockages.
Vacuum turns off on its own.	This vacuum cleaner is equipped with a motor protective thermostat. If for some reason your vacuum overheats, the thermostat will automatically turn the unit off. Should this occur, perform the following steps to restart the motor thermostat: 1. Press the "Power" button to the (Off) position. 2. Unplug the vacuum. 3. Empty the dust cup and clean filters. (See "Maintenance" sections for instructions.) 4. Check for blockages in hose, accessories and inlet openings. (See "Checking for Blockages" for instructions.) 5. Allow the unit to cool for a minimum of 45 minutes. 6. Plug in the vacuum. 7. Press the "Power" button to the (On) position to restart the vacuum.



PRINTED IN MEXICO
OBPN: NV105_NV106_151118_2 SC: 01.31.2019
SHNMDL: NV105_BP RE-DESIGN: 01.25.203_M. C.



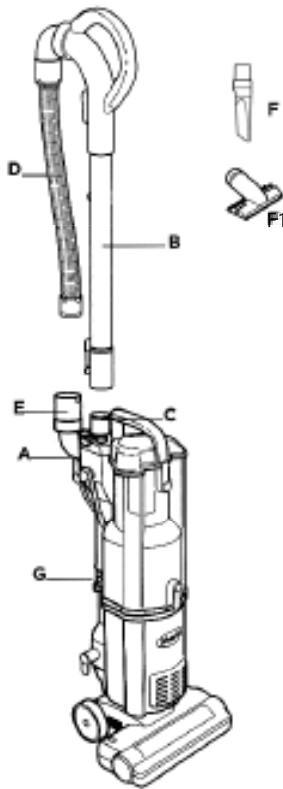

EASY TO ASSEMBLE:

- 1 Insert the hose connector (A) into the opening on the back of the vacuum body.
NOTE: Once the hose connector has been inserted, it cannot be removed.
- 2 Insert the handle with the extension wand (B) into the top of the vacuum (C) until secure.
- 3 Insert the stretch hose (D) into the hose connector (E) on the back of the unit. Make sure that it snaps in place.
- 4 Store your on-board tools (F) onto the accessory holder (G) located on the back of the unit.

USING THE VACUUM:

- 1 Plug in the vacuum.
- 2 Push the "Power" button.
- 3 Place your foot on the power nozzle and pull the handle back towards you.

NOTE: This vacuum has a separate "Brushroll" button on the top of the vacuum.

CLEAN CARPETS:

Engage the brushroll by pushing the "Brushroll" button to the "ON" position. The brushroll light will turn green.

▲ IMPORTANT: To protect all floor surfaces, the brushroll will only turn on when you have pulled the handle back towards you and released the power nozzle. (Fig. 1)

▲ IMPORTANT: The brushroll indicator light on the power nozzle will illuminate solid red if there is a blockage. (Fig. 2)

CLEAN BARE FLOORS:

For cleaning bare floors or to clean with the hose, push the "Brushroll" button to the "OFF" position for suction only. The brushroll light will turn off. (Fig. 1) The brushroll will not spin in this mode.

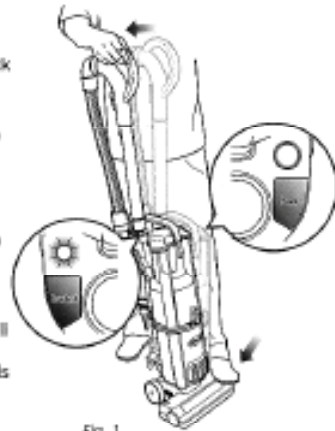

Fig. 1



Fig. 2

Brushroll Indicator Light

804009291A

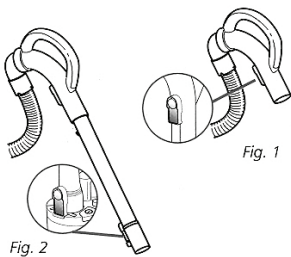

Fig. 1

Fig. 2

CLEAN ABOVE-FLOORS WITH HOSE:

You can attach the accessories onto the handle or onto the extension wand for a longer reach.

- 1 Stand the vacuum into upright position.
- 2 To remove the handle only, press the handle release button. (Fig. 1)
- 3 To remove the handle with the extension wand, press the extension wand release button on the back of the vacuum. (Fig. 2)
- 4 Push the selected tool into the end of the handle or handle with extension wand for longer reach and begin cleaning.

▲ IMPORTANT: Do Not over-extend the hose. Always hold the vacuum so that it does not tip over.

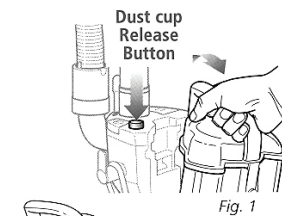

Fig. 1

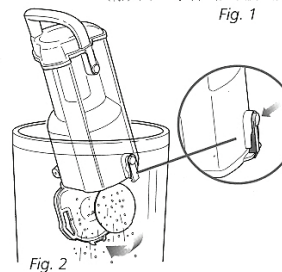

Fig. 2

EMPTY THE DUST CUP

- 1 Press the Dust Cup release button and remove the dust cup from the vacuum. (Fig. 1)
- 2 Grip the carry handle and hold the dust cup over a trash receptacle.
- 3 Press the bottom dust cup release button. Tap the container gently to dislodge and release dust and debris. (Fig. 2)
- 4 Close the bottom door until it snaps in place.

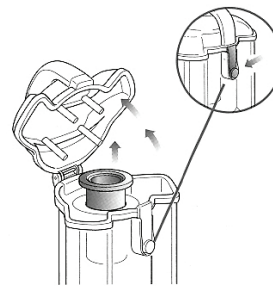
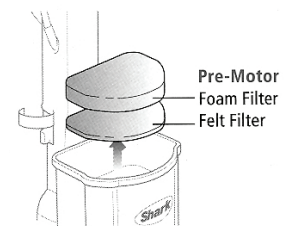

Fig. 3

NOTE: It may become necessary to occasionally clean the metal screen inside the dust cup. To clean, press the top dust cup release button pull out the metal screen and remove any excess dirt. (Fig. 3) Then replace the metal screen inside the dust cup and close the top lid.

Refer to the Owner's Manual for more detailed instructions.



CLEAN THE PRE-MOTOR FILTERS:

▲ IMPORTANT: Loss of Suction may occur if foam filters are not cleaned every month. Rinse and allow to air dry completely. Foam filters may appear dirty after use - this is normal.

Refer to the Owner's Manual for the maintenance schedule.

- 1 With the dust cup removed, pull the 2 filters out from the top of the motor base.
- 2 Rinse the filters thoroughly in lukewarm water until the water runs clear.
- 3 Squeeze out excess water and let air-dry for at least 24 hours before inserting back into the vacuum.



804009291A