

Shark ION ROBOT®

Robot Vacuum for United States only

It's important to read this instruction book prior to using your new product for the first time.

814100040

IMPORTANT SAFETY INSTRUCTIONS

PLEASE READ CAREFULLY BEFORE USE • FOR HOUSEHOLD USE ONLY

If the charging cable plug does not fit fully into the outlet, reverse the plug. If it still does not fit, contact a qualified electrician. DO NOT force into outlet or try to modify to fit.

WARNING

To reduce the risk of fire, electric shock, injury, or property damage:

GENERAL WARNINGS

When using an electrical appliance, basic precautions should always be followed, including the following:

1. Robotic vacuum cleaner consists of a robotic vacuum and charging base with power supply. These components contain electrical connections, electrical wiring, and moving parts that potentially present risk to the user.
2. Before each use, carefully inspect all parts for any damage. If a part is damaged, discontinue use.
3. Use only identical replacement parts.
4. This robotic vacuum cleaner contains no serviceable parts.
5. Use only as described in this manual. DO NOT use the robotic vacuum cleaner for any purpose other than those described in this manual.
6. With the exception of filters, DO NOT expose any parts of the robotic vacuum cleaner to water or other liquids.

USE WARNINGS

7. This appliance can be used by persons with reduced physical, sensory or mental capabilities or lack of experience and knowledge if they have been given supervision or instruction concerning use of the appliance in a safe way and understand the hazards involved.
 - a) Children shall not play with the appliance.
 - b) Cleaning and user maintenance shall not be made by children without supervision.
8. Always turn off the robotic vacuum cleaner before inserting or removing the filter or dust bin.
9. DO NOT handle plug, charging base, charging cable, or robotic vacuum cleaner with wet hands. Cleaning and user maintenance shall not be made by children without supervision.
10. DO NOT use without robot dust bin and filters in place.
11. DO NOT damage the charging cord:
 - a) DO NOT pull or carry charging base by the cord or use the cord as a handle.
 - b) DO NOT unplug by pulling on cord. Grasp the plug, not the cord.
 - c) DO NOT close a door on the cord, pull the cord around sharp corners, or leave the cord near heated surfaces.
12. DO NOT put any objects into nozzle or accessory openings. DO NOT use with any opening blocked; keep free of dust, lint, hair, and anything that may reduce airflow.
13. DO NOT use if robotic vacuum cleaner airflow is restricted. If the air paths become blocked, turn the vacuum cleaner off and remove all obstructions before turning on the unit again.
14. Keep nozzle and all vacuum openings away from hair, face, fingers, uncovered feet, or loose clothing.
15. DO NOT use if robotic vacuum cleaner is not working as it should, or has been dropped, damaged, left outdoors, or dropped into water.
16. DO NOT place vacuum cleaner on unstable surfaces.
17. DO NOT use to pick up:
 - a) Liquids
 - b) Large objects
 - c) Hard or sharp objects (glass, nails, screws, or coins)
 - d) Large quantities of dust (drywall dust, fireplace ash, or embers).
 - e) Smoking or burning objects (hot coals, cigarette butts, or matches)
 - f) Flammable or combustible materials (lighter fluid, gasoline, or kerosene)

- g) Toxic materials (chlorine bleach, ammonia, or drain cleaner)
18. DO NOT use in the following areas:
 - a) Wet or damp surfaces
 - b) Outdoor areas
 - c) Spaces that are enclosed and may contain explosive or toxic fumes or vapors (lighter fluid, gasoline, kerosene, paint, paint thinners, mothproofing substances, or flammable dust)
 - d) Near fireplaces with unobstructed entrances.
 - e) In an area with a space heater.
 19. Turn off the robotic vacuum cleaner before any adjustment, cleaning, maintenance or troubleshooting.
 20. Allow all filters to air-dry completely before replacing in the robotic vacuum cleaner to prevent liquid from being drawn into electric parts.
 21. DO NOT modify or attempt to repair the robotic vacuum cleaner or the battery yourself, except as indicated in this manual. DO NOT use the vacuum if it has been modified or damaged.
 22. To reduce the risk of electric shock, this appliance has a polarized plug (one blade is wider than the other). This plug will fit in a polarized outlet only one way. If the plug does not fit fully in the outlet, reverse the plug. If it still does not fit, contact a qualified electrician to install the proper outlet. Do not change the plug in any way.
 23. In case the self-empty base has a thermal shutoff the unit needs to have a hard power reset to restart.
 24. DO NOT use as an attachment to power tools for dust collection.

BATTERY USE

25. The battery is the power source for the vacuum. Carefully read and follow all charging instructions.
26. To prevent unintentional starting, ensure the vacuum is powered off before picking up or carrying the vacuum. DO NOT carry the appliance with your finger on the power switch.
27. Use ONLY the Shark® charging dock XDCKRV750 and use only battery RVBAT850. Use of batteries or battery chargers other than those indicated may create a risk of fire.
28. Keep the battery away from all metal objects such as paper clips, coins, keys, nails, or screws. Shorting the battery terminals together increases the risk of fire or burns.
29. Under abusive conditions, liquids may be ejected from the battery. Avoid contact with this liquid, as it may cause irritation or burns. If liquid contacts eyes, flush with water. If liquid contacts eyes, seek medical help.
30. Robotic vacuum cleaner should not be stored, charged, or used at temperatures below 50°F (10°C) or above 104°F (40°C). Ensure the battery and vacuum have reached room temperature before charging or use. Exposing the robot or battery to temperatures outside of this range may damage the battery and increase the risk of fire.
31. DO NOT expose the robotic vacuum cleaner or battery to fire or temperatures above 265°F (130°C) as it may cause explosion.
32. Non-rechargeable batteries cannot be recharged.

BOTBOUNDARY® STRIPS (SOLD SEPARATELY)

33. DO NOT put BotBoundary strips underneath carpet or rugs.
34. DO NOT place BotBoundary strips on top of one another.
35. Always use BotBoundary strips around reflective flooring and surfaces.

36. BotBoundary strips should always be used near carpeted stairs.
37. DO NOT place BotBoundary strips within 10 feet of the dock.
38. DO NOT place the charging dock in a room which requires a BotBoundary strip as mentioned in warnings 33 through 37.
39. For your robot's cliff sensors to work properly, all runners, rugs, or carpets must be eight inches from any stairs (or it must be continuous and extend over the edge of the stairs). If a runner, rug or carpet edge that is less than eight inches from the stairs cannot be moved, you must use a BotBoundary strip to block off the stairs.

SAVE THESE INSTRUCTIONS

ABOUT THE SHARK ION ROBOT®

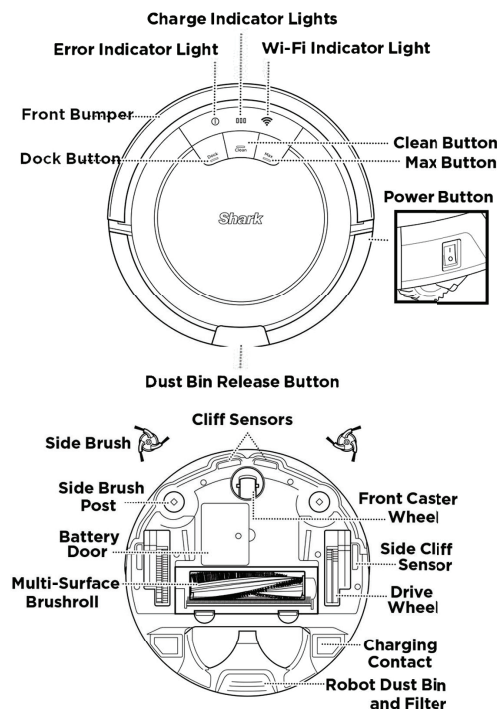

NOTE: Accessories may vary depending on the model. Refer to quick guide, if available. The images shown here are for illustrative purposes only and may be subject to change.

With **Auto-Sense® Navigation**, your robot uses an array of sensors to navigate around walls, furniture legs, and other obstacles while it cleans. The robot may gently bump into obstructions or linger in one spot, and it may not cover every area in a single cleaning. For best results, prepare your home as indicated below, and schedule a daily cleaning to ensure all floor areas are regularly maintained.

Before cleaning, clear away cords and other obstructions, or block off the areas you don't want your robot to travel to.

To prevent your robot from becoming trapped, use furniture risers.

If your robot roams too far, it could have trouble finding the **Charging Dock**. For your robot's cliff sensors to work properly, all runners, rugs, or carpets must be at least

4 inches from any stairs (or extend over the edge of the stairs). If a runner, rug, or carpet edge is less than 4 inches from the stairs and can't be moved, use a BotBoundary® strip to block off the carpet edge. BotBoundary strips are available for purchase at sharkaccessories.com

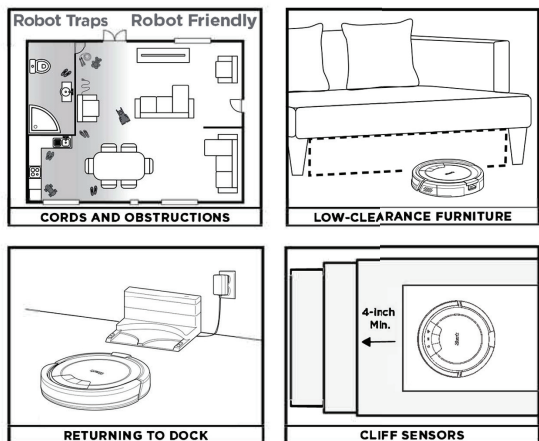

PREPARING FOR USE

INSTALLING THE SIDE BRUSHES

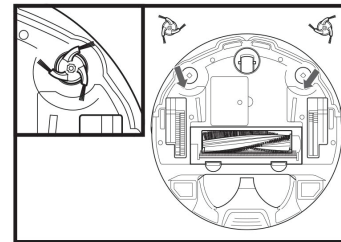

Snap the 2 color-coded **side brushes** onto the matching colored pegs on the bottom of the robot.

CHARGING DOCK SET-UP

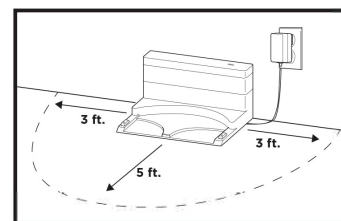

Place the charging dock on a level surface with its back against a wall, in a space without obstructions, that can easily be accessed by your robot. Remove any objects that are closer than 3 feet (1 meter) from either side of the dock, or closer than 5 feet (1.52 meters) from the front of the dock. Plug the **Charging Adapter** into a wall outlet. The dock must be plugged in continually for the robot to find it. The robot will beep when it starts charging on the dock.

NOTE: Placing the dock near reflective objects like mirrors could make docking difficult. To ensure the robot is docked correctly, refer to the **Charge Indicator Lights** section.

CHARGING

IMPORTANT: The Shark ION Robot has a pre-installed rechargeable battery. Battery must be fully charged before using.

1. To charge, the **Power** button on the side of the robot must be in the ON position (I).
2. When the cleaning cycle is complete, or if the battery is running low, the robot will search for the dock.
3. If the robot has no charge and cannot return to the charging dock, place it on the dock manually.
4. Turn the **power switch** on and place your robot on the dock. When all 3 indicator lights illuminate steadily in blue, charging is complete. Allow your robot to charge for 6 hours before sending it to clean.

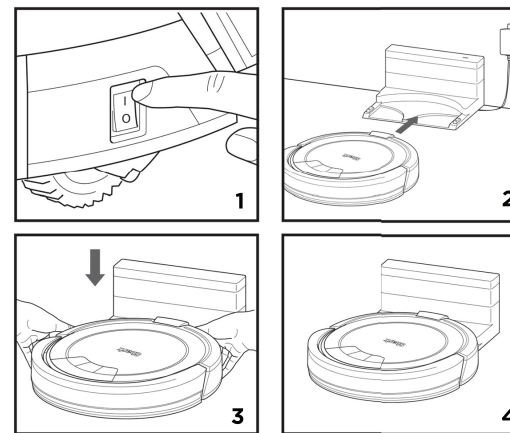

NOTE: When manually placing the robot on the dock, make sure the **Charging Contacts** on the bottom of the robot are aligned with the dock. To ensure the robot is docked correctly, refer to the **Charge Indicator Lights** section.

Note: The BotBoundary strips are not supplied. Sold separately.

CHARGE INDICATOR LIGHTS

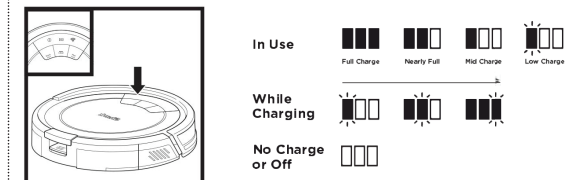

The blue charge indicator lights show how much charge is remaining.

While the robot is charging, all three blue LED lights will cycle. When charging is complete, all three blue lights will illuminate steadily.

If the robot is idle and away from the charging dock for 10 minutes, it will enter **Sleep Mode**, and the lights will turn off.

If all the indicator lights are off, then the robot is in Sleep Mode, the power switch is turned OFF (O) or there is no charge remaining. Turn the power switch ON (I). Press any button to ensure robot is not in Sleep Mode. If all indicator lights remain off, there is no charge. Place the robot on the dock, leaving a half-inch space between the front of the robot and the face of the dock. When the robot is docked correctly and begins to charge, it will beep and the charge indicator lights will cycle.

NOTE: If the low charge light is blinking red, there is not enough charge for the robot to return to the dock. Manually place the robot on the dock, leaving a half-inch space between the front of the robot and the face of the dock.

TIP: To preserve battery life, turn off the power switch if robot will not be used for a long period of time. Unit should be recharged at least once every three months.

USING THE SHARK ION ROBOT®

MANUAL CLEANING MODE

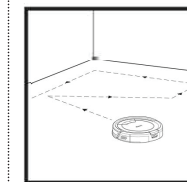

To manually start a cleaning cycle, press the **Clean** button on the robot or on the mobile app. To stop the robot before it finishes cleaning and automatically returns to the dock, press the button again.

IMPORTANT: Before cleaning an entire room for the first time, we recommend that you first test your robot on a small section of the floor to ensure there is no scratching.

BUTTONS AND INDICATOR LIGHTS

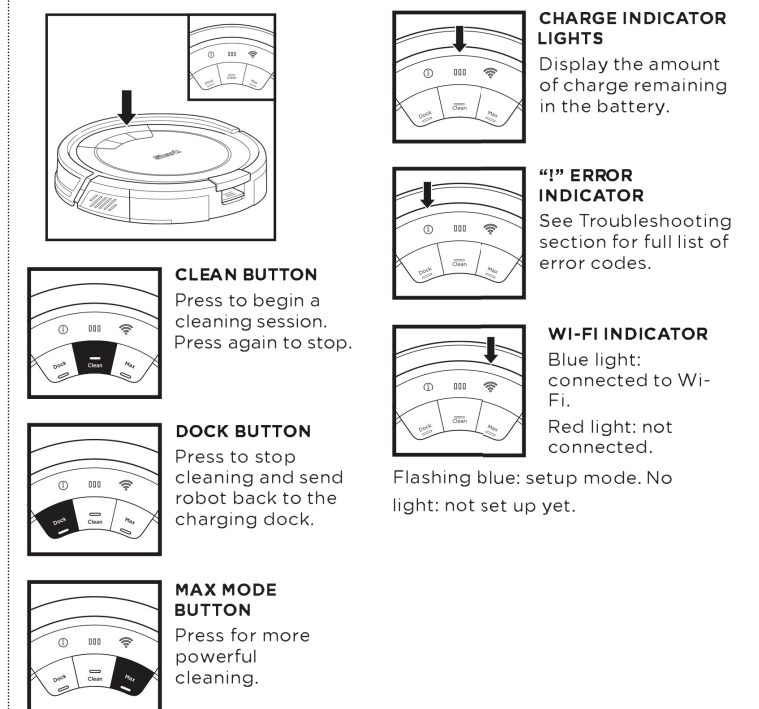

USING THE SHARKCLEAN® APP AND VOICE CONTROLS

The SharkClean app will guide you through easy setup of your robot. Control the unit remotely:

- Schedule cleaning times for up to 7 days a week.
- Start, stop, or dock your robot from your phone anywhere with Wi-Fi connectivity.

The app will also provide you access to:

- Tips, Tricks, and FAQs
- Tech Support
- Troubleshooting

Search for **SharkClean** in the app store and download the app to your iPhone™ or Android™.



SETTING UP THE SHARKCLEAN® APP

Download the latest version of the SharkClean app from the App Store or Google Play store.

Follow instructions on the app to connect to the robot. To ensure the app successfully pairs with the robot:

- Confirm your Wi-Fi router and/or home network supports a 2.4 GHz network.
- Confirm your Wi-Fi network name.
- Confirm your Wi-Fi network password.

CAN'T CONNECT TO WI-FI?

- **Restart your phone**
- **Restart your robot**
 - Press the power button on the side of the robot to the OFF position. Press it again to turn power back on.
- **Reboot your router**
 - Unplug the router power cable for 10 seconds, then plug it back in. Allow several minutes for your router to reboot completely.

MAINTENANCE

CAUTION: Turn off power before performing any maintenance.

EMPTYING THE DUST BIN

EMPTY DUST BIN AFTER EACH USE.

Press the **Dust Bin Release Button** and slide out the dust bin. To open the dust bin lid, press and hold the button while lifting the lid, using the finger slots.

Empty debris and dust into trash.

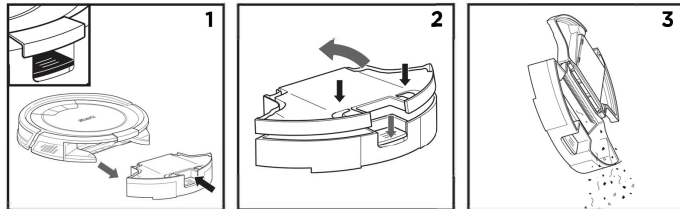

CLEANING THE FILTER

CLEAN FILTER EVERY WEEK. REPLACE FILTERS REGULARLY OR AS NEEDED.

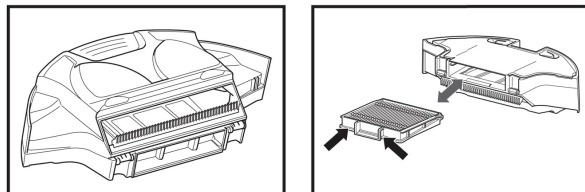

Remove and empty the dust bin. Clean any hair or debris off the **Anti-Tangle Comb** on the back of the dust bin.

Pull filter out of the dust bin by the tabs.

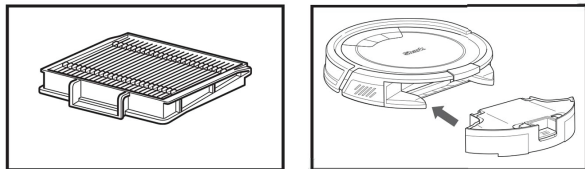

Lightly tap the filter to remove dust and debris.

Reinsert the filter into the dust bin. Slide the dust bin back into the robot.

Note: The BotBoundary strips are not supplied. Sold separately.

CLEANING THE MULTI-SURFACE BRUSHROLL

THE BRUSHROLL NEEDS OCCASIONAL MAINTENANCE. REPLACE BRUSHROLL EVERY 6 TO 12 MONTHS, OR WHEN VISIBLY WORN.

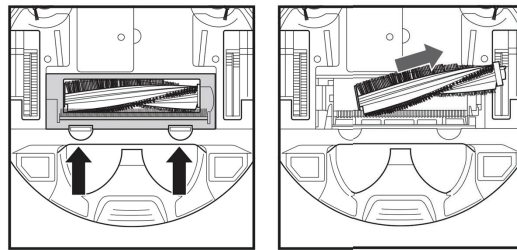

Push up on the tabs on the brushroll access door, then lift off the door.

Lift out the brushroll.

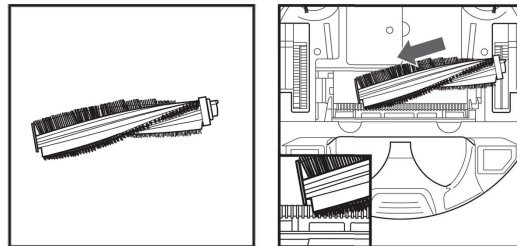

Clean off any hair or debris wrapped around the body of the brushroll and the end cap. Clean the brushroll periodically and whenever hair appears.

Reinstall the brushroll, inserting the flat end first. Close the brushroll access door and press down until it clicks into place.

NOTE: If the metal cylinder falls out of the brushroll cap, reinsert it in the hole on the inside of the cap. When cutting away debris, be sure not to cut the brushroll or any other parts of the robot.

CLEANING SENSORS AND CHARGING PADS

CLEAN SENSORS AND CHARGING PADS PERIODICALLY AS NEEDED. With a dry cloth or cleaning brush, gently dust off the sensors and pads located on the bottom of the robot.

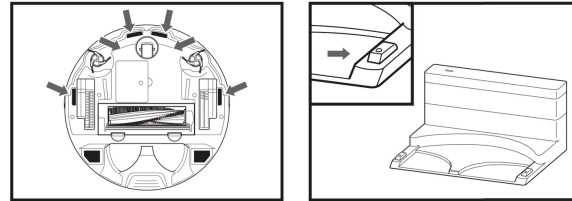

IMPORTANT: The robot uses cliff sensors to avoid stairs and other steep drops. Sensors may work less effectively when they are dirty. For best results, clean sensors regularly.

CLEANING SIDE BRUSHES

CLEAN SIDE BRUSHES AS NEEDED. CHECK WEEKLY. **RECOMMENDED REPLACEMENT SCHEDULE:** Replace when visibly worn.

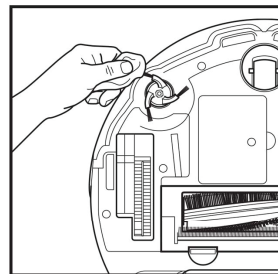

Carefully unwind and remove any string or hair wrapped around brushes. Gently wipe brushes with a damp cloth. Be sure to let them air-dry completely before reinstalling them.

NOTE: Remove any side brushes that are bent or damaged. To remove a brush, lift it off its peg. See **Installing the Side Brushes** for instructions on how to attach and remove the brushes.

CLEANING THE WHEELS

REMOVE AND CLEAN FRONT WHEEL EVERY WEEK. REPLACE FRONT WHEEL EVERY 12 MONTHS. See sharkaccessories.com for replacement parts.

1. Pull the **Front Caster Wheel** from its housing and remove any debris buildup.
2. Clean the wheel housing, then reinsert the caster wheel.
3. Clean the drive wheel housing periodically as needed by rotating the wheel while dusting.

NOTE: Accessories may vary depending on the model. Refer to quick guide, if available. The images shown here are for illustrative purposes only and may be subject to change.

NOTE: Leverage may be required to remove the wheel.

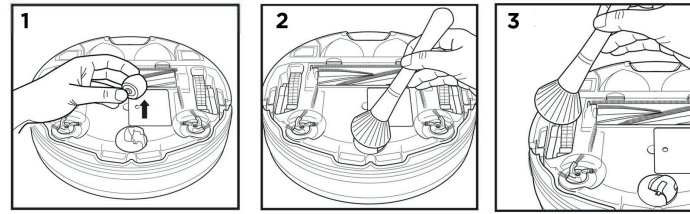

REPLACING THE BATTERY

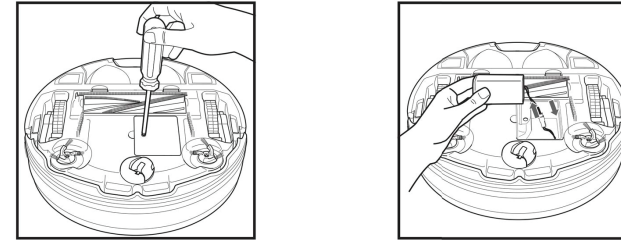

To remove the battery, turn the unit over and unscrew the battery cover with a Phillips-head screwdriver.

Unplug the old battery from its connector, then plug in the new battery. Replace battery cover and screw it back into place. See **Battery Removal and Disposal** on back cover.

NOTE: This appliance contains batteries that are only replaceable by skilled persons.

REFURBISHED PRODUCT LIMITED NINETY DAYS WARRANTY

The **Refurbished Product Service Center** offers the following WARRANTY to the ORIGINAL purchaser of a product which we have refurbished.

This product that has been refurbished is warranted against any electronic or mechanical defects for a period of NINETY DAYS from the date of the original purchase by the consumer. Since this unit was sold as a refurbished item, the warranty does not apply to any cosmetic appearance items such as scratches. Should a defect occur, the **Refurbished Product Service Center** will repair or, at its option, replace defective unit/parts with new or rebuilt materials without charge for either parts or labor. Replacement unit/parts will be warranted for the remaining portion of the original warranty period.

This warranty does not cover installation or damage from accident, misuse, abuse, improper wiring, incorrect voltage, operating the unit against the instructions in the owner's manual or any product which has been opened, altered, or tampered with.

This warranty does not cover costs for removal and or installation of the unit for repair. Under no circumstances shall the service center be liable for any special, incidental or consequential damages or for any other expenses incurred by reason of use or sale of this product. This warranty is in lieu of any other warranties expressed or implied warranty of merchantability of fitness for particular use or otherwise.

This warranty gives the consumer specific legal rights and they may also have other rights which vary from State to State. Some States do not follow the exclusion or limitation of incidental or consequential damages, hence the above exclusion and limitations may not apply.

**Refurbished Product Service Center,
13225 Marquardt Avenue Santa Fe Springs, CA 90670.**

WARRANTY REPAIR INFORMATION

If you need service on your unit and this product requires repair during the 90 days warranty period; please go to www.ConsumerServiceRefurbish.com or call the **Refurbished Product Service Center** at 562-946-3531 to obtain the required return authorization (RA) number. Pack the unit properly (the original carton is ideal for this purpose) along with a copy of your purchase receipt and a letter describing the problem. Send the unit freight prepaid and insured to:

**Refurbished Product Service Center,
Att: Customer Service Department 13225 Marquardt Avenue Santa Fe Springs, CA 90670**

Your unit will be promptly repaired and returned to you. We will refuse to accept delivery of the returned unit unless the assigned RA number appears on the outside of the shipping carton.

Owner's Information
(Keep for your permanent records)

NAME: _____

ADDRESS: _____

CITY: _____ STATE: _____ ZIP CODE: _____

PHONE: _____ E-MAIL: _____

MODEL: _____ SERIAL NO.: _____

TROUBLESHOOTING

If any error lights are illuminated or flashing on your Shark Ion Robot®, see the error code chart below:

ERROR CODE	SOLUTION
ALL LED LIGHTS are off	Power may be turned off or battery may need charging. Turn power switch to On position. If no response, place robot on dock to charge.
CLEAN (RED) + ! flashing together	Suction motor failure. Remove blockages and clean filters. Remove dust bin and make sure nothing is blocking suction.
CLEAN (RED) flashing	Robot may be stuck on an obstacle. Move robot to a new location on a level surface.
MAX flashing	Robot may be stuck on an obstacle. Move robot to a new location on a level surface. Front bumper may be jammed. Check bumper.
CLEAN (RED) + DOCK flashing together	Cliff sensors are reporting an error. Wipe cliff sensors with a clean cloth. Robot cannot start due to an error. Turn off the power switch on the side of the robot, wait five seconds, then turn power back on. Ensure your robot is on a level surface with no obstructions.
CLEAN (RED) + MAX flashing together	The dust bin has been removed and needs to be reinserted.
MAX + ! flashing together	A side brush is stuck. Remove debris from side brushes.
CLEAN (RED) + MAX + ! flashing together	A drive wheel is stuck. Remove debris from wheel.
DOCK + MAX + ! flashing together	Blockage in brushroll. Remove obstruction.
DOCK + ! flashing together	Make sure you are using the dock that came with your robot.
CLEAN (BLUE) + MAX + ! flashing together	The robot is caught in a tight space or on an obstacle. There is something stuck in the robot's front bumper. Clean any obstructions or debris from the bumper. Gently push the bumper up and down and back and forth, making sure it moves smoothly.
CLEAN + DOCK + MAX + ! flashing together	The robot's wheels might be stuck, or something might be caught in them. Check the wheels for obstructions and remove anything that might be stuck or wrapped around the wheels. Press down on the wheels, then let them spring back into place. Rotate wheels back and forth.
CLEAN + DOCK + MAX flashing together	Robot is in Find My Robot mode. You can deactivate this mode in the app.

For all other issues, please Contact a Service center.

PLEASE READ CAREFULLY AND KEEP FOR FUTURE REFERENCE.

This Owner's Guide is designed to help you keep your Shark Ion Robot® running at peak performance.

SharkNinja Operating LLC

Illustrations may differ from actual product. We are constantly striving to improve our products; therefore the specifications contained herein are subject to change without notice.

This product may be covered by one or more U.S. patents. See sharkninja.com/patents for more information.



814100040



PRINTED IN MEXICO Elbrd: M.C. SC: 03-24-2023_TAB
OBPN: RV700Series_IB_iii_MP_Mv4_220324 MODEL: RV754X01US_B
Add: RV763X01US_RV765X01US_RV772X01US