

It's important to read this instruction book prior using your new product for the first time.

804106425A

SAFETY INFORMATION

The following also applies to the Wireless Subwoofer (PS-WR65B).

SAFETY WARNINGS
TO REDUCE THE RISK OF ELECTRIC SHOCK, DO NOT REMOVE THE COVER (OR BACK). NO USER-SERVICEABLE PARTS ARE INSIDE. REFER SERVICING TO QUALIFIED SERVICE PERSONNEL.
Refer to the table below for an explanation of symbols which may be on your Samsung product.

	CAUTION RISK OF ELECTRIC SHOCK. DO NOT OPEN.
	This symbol indicates that high voltage is present inside. It is dangerous to make any kind of contact with any internal part of this product.
	This symbol indicates that this product comes with important literature concerning operation and maintenance.
	Class II product : This symbol indicates that a safety connection to electrical earth (ground) is not required. If this symbol is not present on a product with a power cord, the product MUST have a reliable connection to protective earth (ground).
	AC voltage : Rated voltage marked with this symbol is AC voltage.
	DC voltage : Rated voltage marked with this symbol is DC voltage.
	Caution. Consult Instructions for use : This symbol instructs the user to consult the user manual for further safety related information.

WARNING

- To reduce the risk of fire or electric shock, do not expose this appliance to rain or moisture.
- To prevent injury, this apparatus must be securely attached to the floor/wall in accordance with the installation instructions.
- This product contains chemicals known to the State of California to cause cancer and birth defects or other reproductive harm.

CAUTION

- Do not expose this apparatus to dripping or splashing. Do not put objects filled with liquids, such as vases, on the apparatus.
- To turn this apparatus off completely, you must pull the power plug out of the wall socket. Consequently, the power plug must be easily and readily accessible at all times.

FCC NOTE (for U.S.A.):
FCC Supplier's Declaration of Compliance
The party responsible for product compliance: Samsung Electronics America, Inc. QA Lab America 19 Chapin Rd. Building D Pine Brook NJ 07058

FCC Compliance Statement:
This device complies with Part 15 of the FCC Rules. Operation is subject to the following two conditions:
(1) This device may not cause harmful interference, and (2) this device must accept any interference received, including interference that may cause undesired operation.

FCC Caution:

- Any changes or modifications not expressly approved by the party responsible for compliance could void the user's authority to operate this equipment.
- This product satisfies FCC regulations when shielded cables and connectors are used to connect the unit to other equipment. To prevent electromagnetic interference with electric appliances, such as radios and televisions, use shielded cables and connectors for connections.

Class B FCC Statement
This equipment has been tested and found to comply with the limits for a Class B digital device, pursuant to Part 15 of the FCC Rules. These limits are designed to provide reasonable protection against harmful interference in a residential installation. This equipment generates, uses and can radiate radio frequency energy and, if not installed and used in accordance with the instructions, may cause harmful interference to radio communications. However, there is no

guarantee that interference will not occur in a particular installation. If this equipment does cause harmful interference to radio or television reception, which can be determined by turning the equipment off and on, the user is encouraged to try to correct the interference by one of the following measures:

- Reorienting or relocating the receiving antenna.
- Increasing the separation between the equipment and receiver.
- Connecting the equipment to an outlet that is on a different circuit than the radio or TV.
- Consulting the dealer or an experienced radio/TV technician for help.

FCC Radiation Exposure Statement:
This equipment complies with FCC radiation exposure limits set forth for an uncontrolled environment. This equipment should be installed and operated so there is at least 8 inches (20 cm) between the radiator and your body. This device and its antenna(s) must not be co-located or operated in conjunction with any other antenna or transmitter.

ABOUT THIS MANUAL

The user manual has two parts: this simple paper USER MANUAL and a detailed FULL MANUAL you can download.

USER MANUAL
See this manual for safety instructions, product installation, components, connections, and product specifications.

Design and specifications are subject to change without prior notice.

CHECKING THE COMPONENTS

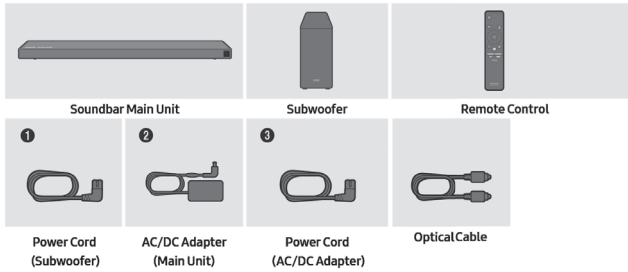

- For more information about the power supply and power consumption, refer to the label attached to the product. (Label: Bottom of the Soundbar Main Unit)
- The power components are labelled (1, 2, 3).
- To purchase additional components or optional cables, contact a Service Center.

Inserting Batteries before using the Remote Control

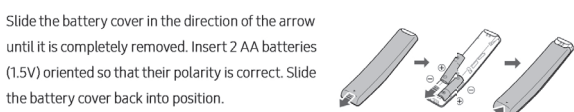

The cables mentioned in this manual are not supplied with your unit.

PRODUCT OVERVIEW

Front Panel / Right Side Panel of the Soundbar

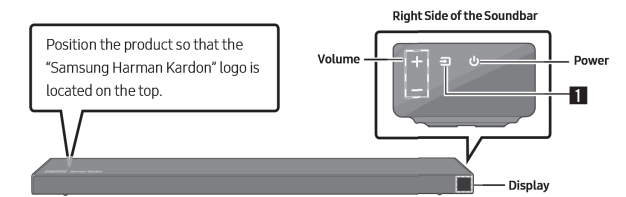

Bottom Panel of the Soundbar

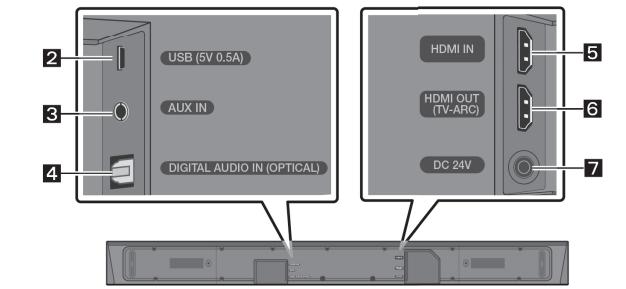

1	Source	Selects the source input mode. (D.IN / AUX / HDMI / BT / USB) • To turn on "BT PAIRING" mode, change the source to "BT" mode, and then press and hold the Source button for more than 5 seconds.
2	USB	Connect a USB device here to play music files on the USB device through the Soundbar.
3	AUX	Connect to the Analog output of an external device.
4	D.IN	Connect to the digital (optical) output of an external device.
5	HDMI IN	Inputs digital video and audio signals simultaneously using an HDMI cable. Connect to the HDMI output of an external device.
6	HDMI OUT	Connect to the HDMI (ARC) jack on a TV.
7	DC 24V	Connect the AC/DC power adapter. (Power Supply In)

The image shown here is for illustrative purposes only and may be subject to change. The actual number of ports and their locations may vary depending on the model.

CONNECTING THE SOUNDBAR

Connecting Electrical Power

Use the power components (1, 2, 3) to connect the Subwoofer and Soundbar to an electrical outlet in the following order:

- Connect the power cord to the Subwoofer.
- Connect the power output cable to the power adapter, and then to the Soundbar.
- Connect the power cord to a wall socket.

See the illustrations below.

- For more information about the required electrical power and power consumption, refer to the label attached to the product. (Label: Bottom of the Soundbar Main Unit)

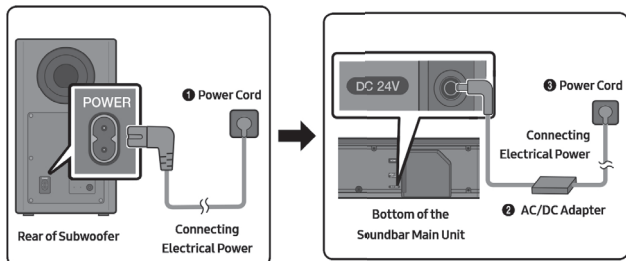

- Make sure to rest the AC/DC Adapter flat on a table or the floor. If you place the AC/DC Adapter so that it is hanging with the AC cord input facing upwards, water or other foreign substances could enter the Adapter and cause the Adapter to malfunction.

Manually connecting the Subwoofer if automatic connection fails

Before performing the manual connection procedure below:

- Check whether the power cables for the Soundbar and subwoofer are connected properly.
- Make sure that the Soundbar is turned on.

- Press and hold **ID SET** on the rear of the subwoofer for at least 5 seconds.
 - The red indicator on the rear of the subwoofer turns off and the blue indicator blinks.

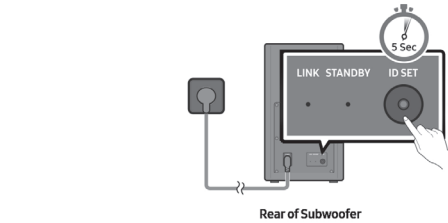

- Press and hold the **Up** button on the remote control for at least 5 seconds.
 - The **ID SET** message appears on the display of the Soundbar for a moment, and then it disappears.
 - The Soundbar will automatically power on when **ID SET** is complete.

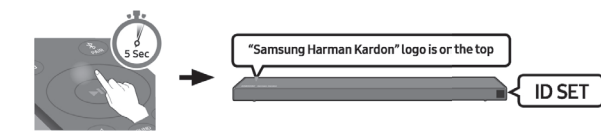

- Check if the **LINK** LED is solid blue (connection complete).

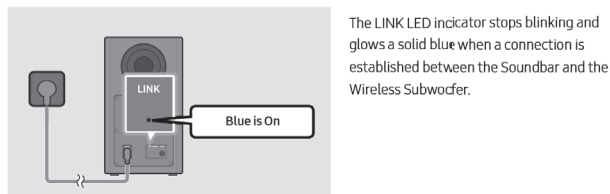

Connecting an SWA-8500S (Sold Separately) to your Soundbar

Expand to true wireless surround sound by connecting the Samsung Wireless Rear Speaker Kit (SWA-8500S, sold separately) to your Soundbar.

- Connect the Wireless Receiver Module to 2 Surround Speakers.
 - The speaker cables are color coded.

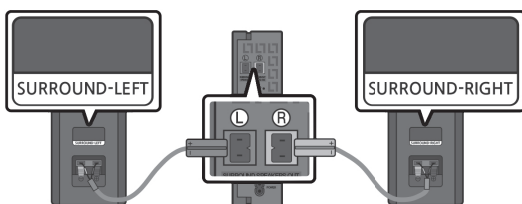

- Press and hold the **Up** button on the remote control for at least 5 seconds.
 - The **ID SET** message appears on the display of the Soundbar for a moment, and then it disappears.
 - The Soundbar will automatically power on when **ID SET** is complete.

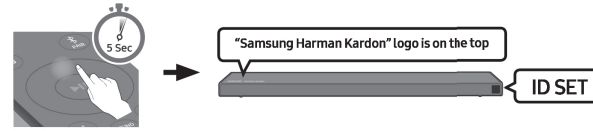

CAUTION

- If your Soundbar was playing music when it connects to the SWA-8500S, you may hear some stuttering from the woofer as the connection finalizes.

- Check if the **LINK** LED is solid blue (connection complete).

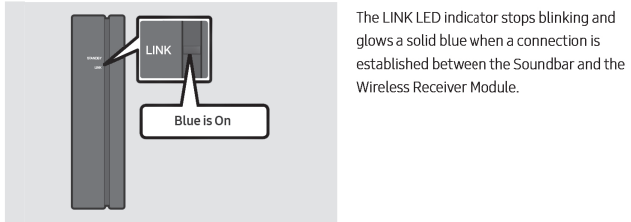

- If the SWA-8500S is not connected, repeat the procedure from Step 2.

CONNECTING TO YOUR TV

Hear TV sound from your Soundbar through wired or wireless connections.

- When the Soundbar is connected to selected Samsung TVs, the Soundbar can be controlled using the TV's remote control.
 - This feature is supported by 2017 and later Samsung Smart TVs that support Bluetooth when you connect the Soundbar to the TV using an optical cable.
 - This function also allows you to use the TV menu to adjust the sound field and various settings as well as the volume and mute.

Method 1. Connecting with a Cable

When the audio in a broadcast is encoded in Dolby Digital and the "Digital Output Audio Format" on your TV is set to PCM, we recommend that you change the setting to Dolby Digital. When the setting on the TV is changed, you will experience better sound quality. (The TV menu may use different words for Dolby Digital and PCM depending on the TV manufacturer.)

Connecting a TV using an HDMI Cable

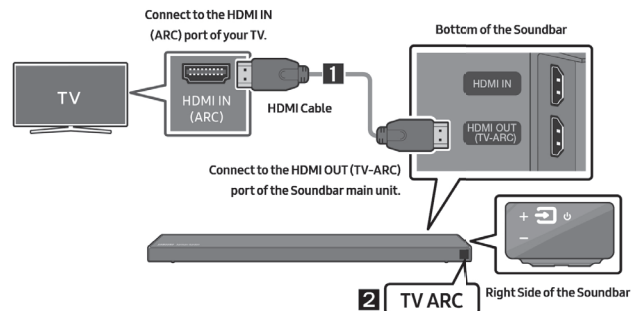

- With the Soundbar and TV turned on, connect the HDMI cable as shown in the figure.
- "**TV ARC**" appears in the display window of the Soundbar main unit and the Soundbar plays TV sound.
 - If TV sound is inaudible, press the **Source** button on the remote control or on the right side of the Soundbar to switch to "D.IN" mode. The screen displays "D.IN" and "TV ARC" in sequence, and TV sound is played.
 - If "TV ARC" does not appear in the display window of the Soundbar main unit, confirm that the HDMI cable is connected to the correct port.
 - Use the volume buttons on the TV's remote control to change the volume on the Soundbar.

Connecting using an Optical Cable

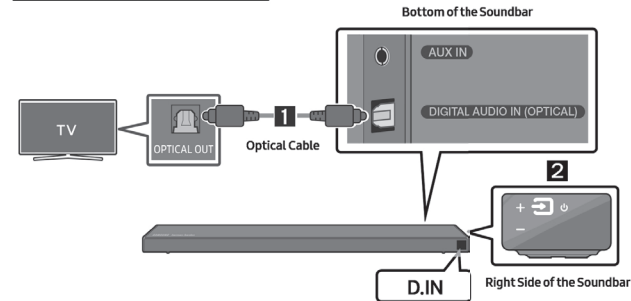

- Connect the **DIGITAL AUDIO IN (OPTICAL)** jack on the Soundbar to the **OPTICAL OUT** jack of the TV with a digital optical cable.
- Press the **Source** button on the right side panel or remote control, and then select the "D.IN" mode.

Auto Power Link

Auto Power Link automatically turns on the Soundbar when the TV is turned on.

- Connect the Soundbar and a TV with a digital optical cable as described in Step 1 above.
- Press the **Left** button on the remote control (the blue spot in the illustration to the right) for 5 seconds to turn Auto Power Link on or off.
 - Auto Power Link is set to ON by default. (To turn off this function, hold the **Left** button on the remote for 5 seconds.)
 - Depending on the connected device, Auto Power Link may not function.
 - This function is only available in the "D.IN" mode.

Method. Connecting Wirelessly

Connecting a TV via Bluetooth

When a TV is connected using Bluetooth, you can hear stereo sound without the hassle of cabling.

- Only one TV can be connected at a time.

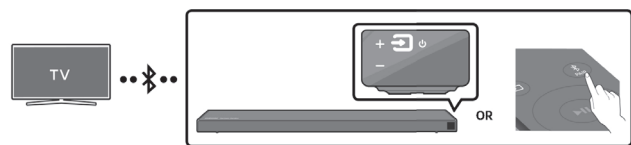

The initial connection

- Press the **PAIR** button on the remote control to enter the "BT PAIRING" mode.
 - (OR) a. Press the **Source** button on the right side panel and then select "BT". "BT" changes to "BT READY" in a few seconds automatically if there is no Bluetooth device connected to the Soundbar.
 - b. When "BT READY" appears, press and hold the **Source** button on the right side panel of the Soundbar for more than 5 seconds to display "BT PAIRING".
- Select Bluetooth mode on the TV. (For more information, see the TV's manual.)
- Select "[AV] Samsung Soundbar Q6R-Series" from the list on TV's screen. An available Soundbar is indicated with "Need Pairing" or "Paired" on the TV's Bluetooth device list. To connect the TV to the Soundbar, select the message, and then establish a connection.
 - When the TV is connected, [TV Name] -> "BT" appears on the Soundbar's front display.
- You can now hear TV sound from the Soundbar.

If the device fails to connect

- If a previously connected Soundbar listing (e.g. "[AV] Samsung Soundbar Q6R-Series") appears in the list, delete it.
- Then repeat steps 1 through 3.

Disconnecting the Soundbar from the TV

Press the **Source** button on the right side panel or on the remote control and switch to any mode but "BT".

- Disconnecting takes time because the TV must receive a response from the Soundbar. (The time required may differ, depending on the TV model.)
- To cancel the automatic Bluetooth connection between the Soundbar and TV, press the **Play/Pause** button on the remote control for 5 seconds with the Soundbar in "BT READY" status. (Toggle On → Off)

What is the difference between BT READY and BT PAIRING?

- BT READY** : In this mode, you can search for previously connected TVs or connect a previously connected mobile device to the Soundbar.
- BT PAIRING** : In this mode, you can connect a new device to the Soundbar. (Press the **PAIR** button on the remote control or press and hold the **Source** button on the right side of the Soundbar for more than 5 seconds while the Soundbar is in "BT" mode.)

NOTES

- If asked for a PIN code when connecting a Bluetooth device, enter <0000>.
- In Bluetooth connection mode, the Bluetooth connection will be lost if the distance between the Soundbar and the Bluetooth device exceeds 32.8 ft.
- The Soundbar automatically turns off after 20 minutes in the Ready state.
- The Soundbar may not perform Bluetooth search or connection correctly under the following circumstances:
 - If there is a strong electrical field around the Soundbar.
 - If several Bluetooth devices are simultaneously paired with the Soundbar.
 - If the Bluetooth device is turned off, not in place, or malfunctions.
- Electronic devices may cause radio interference. Devices that generate electromagnetic waves must be kept away from the Soundbar main unit - e.g., microwaves, wireless LAN devices, etc.

CONNECTING AN EXTERNAL DEVICE

Connect to an external device via a wired or wireless network to play the external device's sound through the Soundbar.

Connecting using an HDMI Cable

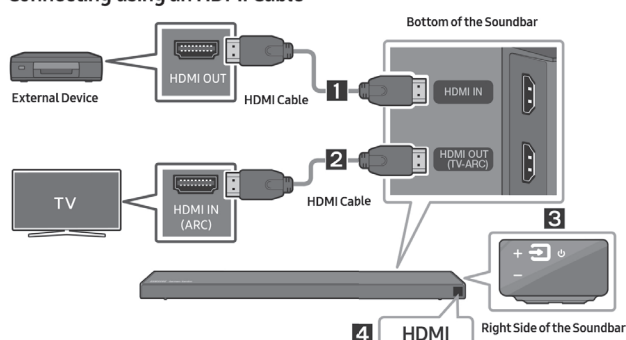

- Connect an HDMI cable from the **HDMI IN** jack on the back of the product to the HDMI OUT jack on your digital device.
- Connect an HDMI cable from the **HDMI OUT (TV-ARC)** jack on the back of the product to the HDMI IN jack on your TV.
- Press the **Source** button on the right side panel or on the remote control, and then select "HDMI".
- "HDMI" mode is displayed on the Soundbar display panel and sound plays.

CONNECTING A USB STORAGE DEVICE

You can play music files located on USB storage devices through the Soundbar.

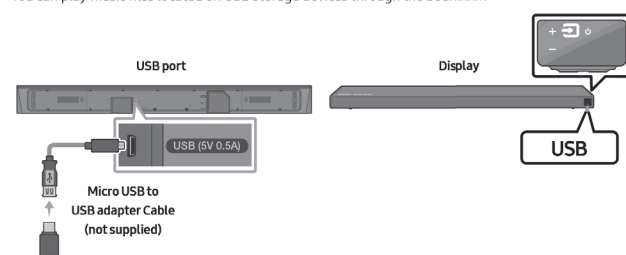

- Connect a Micro USB to USB adapter cable with a male USB 2.0 Micro USB plug (Type B) on one end and a standard female 2.0 USB jack (Type A) on the other end to the micro USB jack on your Soundbar.
 - The Micro USB to USB adapter cable is sold separately. To purchase, contact a Service Center.
- Connect your USB device to the female end of the adapter cable.
- Press the **Source** button on the right side panel or on the remote control, and then select "USB".
- "USB" appears in the display screen.
- Play music files from the USB storage device through the Soundbar.
 - The Soundbar automatically turns off (Auto Power Down) if no USB device has been connected for more than 20 minutes.

Software Update

Samsung may offer updates for the Soundbar's system firmware in the future.

If an update is offered, you can update the firmware by connecting a USB device with the firmware update stored on it to the USB port on your Soundbar. Note that the option names can vary.

CONNECTING A MOBILE DEVICE

Connecting via Bluetooth

When a mobile device is connected using Bluetooth, you can hear stereo sound without the hassle of cabling.

- You cannot connect more than one Bluetooth device at a time.

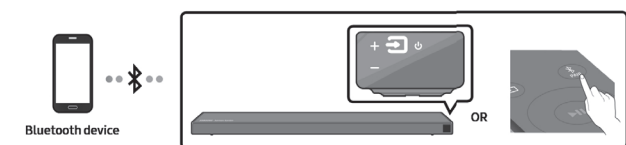

The initial connection

- Press the **PAIR** button on the remote control to enter the "BT PAIRING" mode.
 - Press the **Source** button on the right side panel and then select "BT". "BT" changes to "BT READY" in a few seconds automatically if there is no Bluetooth device connected to the Soundbar.
 - When "BT READY" appears, press and hold the **Source** button on the right side panel of the Soundbar for more than 5 seconds to display "BT PAIRING".
- On your device, select "[AV] Samsung Soundbar Q6R-Series" from the list that appears.
 - When the Soundbar is connected to the Bluetooth device, [Bluetooth Device Name] → "BT" appears in the front display.
- Play music files from the device connected via Bluetooth through the Soundbar.

If the device fails to connect

- If a previously connected Soundbar listing (e.g. "[AV] Samsung Soundbar Q6R-Series") appears in the list, delete it.
- Then repeat steps 1 and 2.

NOTE

- After you have connected the Soundbar to your mobile device the first time, use the "BT READY" mode to reconnect.

For more information about Bluetooth connections, refer to "Connecting a TV via Bluetooth".

USING THE REMOTE CONTROL

How to Use the Remote Control

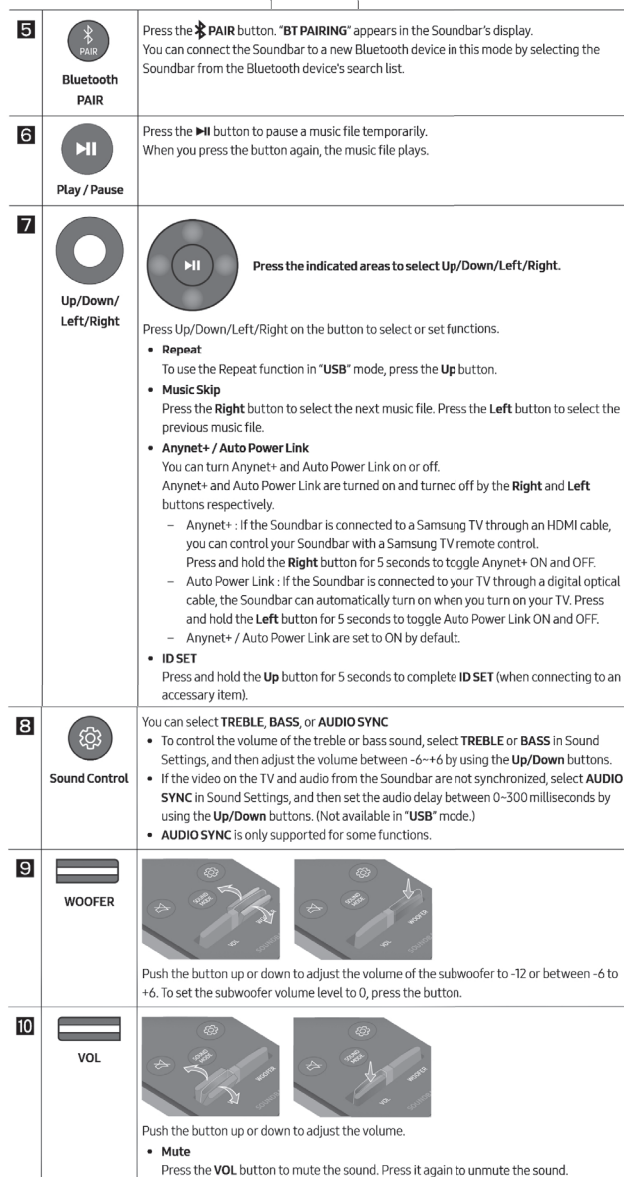
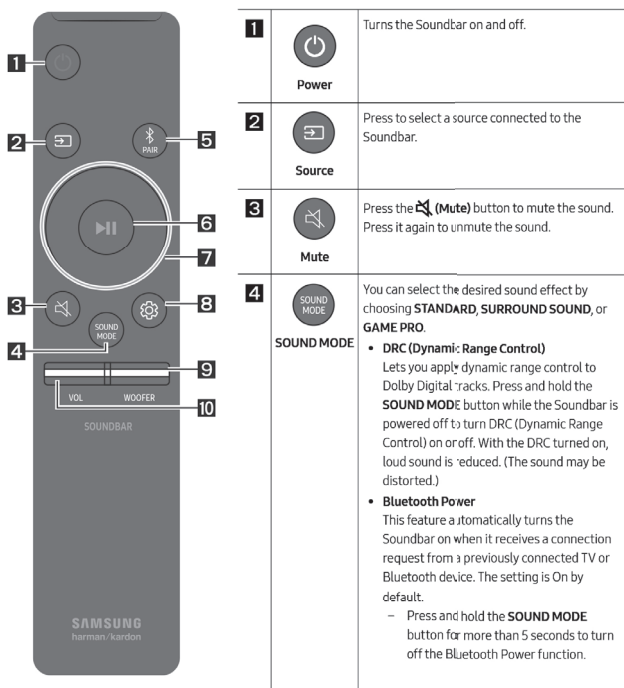

*The remote control may vary depending on the model: The buttons on remote control may have a different name or location than the remote control shown in this manual.

Adjusting the Soundbar volume with a TV remote control

If you have a Samsung TV, you can adjust the Soundbar's volume using the IR remote control that came with your Samsung TV.

First use the TV menu to set the TV audio on your Samsung TV to external speakers, then use your Samsung remote to control the Soundbar's volume. For more information, see the TV's user manual. The default mode for this function is control by a Samsung TV remote. If your TV is not a Samsung TV, follow the directions below to change the settings of this function.

- Turn Off the Soundbar.

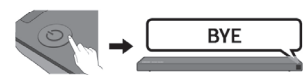

- If you do not want to use this function, push up and hold the **WOOFER** button for 5 seconds repeatedly until "OFF-TV REMOTE" appears in the display.



- If you want to control the Soundbar with your TV's remote, push up and hold the **WOOFER** button for 5 seconds repeatedly until "ALL-TV REMOTE" appears in the display. Then, use your TV's menu to select external speakers.



- If you want to return the Soundbar to the default mode (control by a Samsung TV remote), push up and hold the **WOOFER** button for 5 seconds repeatedly until "SAMSUNG-TV REMOTE" appears in the display.

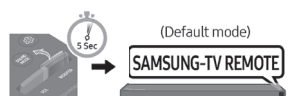

- Each time you push the **WOOFER** button up and hold it for 5 seconds, the mode switches in the following order: "SAMSUNG-TV REMOTE" (Default mode) → "OFF-TV REMOTE" → "ALL-TV REMOTE".
- This function may not be available, depending on the remote control.
- This volume control function works with IR TV remotes only. It does not work with Bluetooth TV remotes (remotes that require pairing).

TROUBLESHOOTING

Refer to the table below if this product does not function properly. If the problem you are experiencing is not listed below or if the instructions below do not help, turn off the product, disconnect the power cord, and contact a service center.

The unit will not turn on.
Is the power cord plugged into the outlet? → Connect the power plug to the outlet.
A function does not work when the button is pressed.
Is there static electricity in the air? → Disconnect the power plug and connect it again.
Sound dropouts occur in BT mode.
→ See the Bluetooth connection.
Sound is not produced.
Is the Mute function on? → Press the Mute button to cancel the mute function.
Is the volume set to minimum? → Adjust the Volume.
The remote control does not work.
Are the batteries drained? → Replace with new batteries.
Is the distance between the remote control and Soundbar main unit too far? → Move the remote control closer to the Soundbar main unit.
The red LED on the subwoofer blinks and the subwoofer is not producing sound.
This issue can occur if the subwoofer is not connected to the Soundbar main unit. → Try to connect your subwoofer again.
The subwoofer drones and vibrates noticeably.
Try to adjust the vibration of your subwoofer. → Push the WOOFER button on your remote control up or down to adjust the subwoofer volume. (to -12, or between -6 ~ +6).

SPECIFICATIONS AND GUIDE

Specifications

Model Name	HW-Q6CR
USB	5V/0.5A
Weight	7.9 lbs (3.6 kg)
Dimensions (W x H x D)	43.3 x 2.3 x 3.9 inches (1100.0 x 59.0 x 100.0 mm)
Operating Temperature Range	+41°F to +95°F (+5°C to +35°C)
Operating Humidity Range	10 % ~ 75 %
AMPLIFIER	
Rated Output power	30W x 6 + 10W x 2
Supported play formats	LPCM 2ch, Dolby Audio™ (supporting Dolby® Digital), DTS

Subwoofer Name	PS-WR65B
Weight	13.7 lbs (6.2 kg)
Dimensions (W x H x D)	8.1 x 13.9 x 11.9 inches (205.0 x 353.0 x 303.2 mm)
AMPLIFIER	
Rated Output power	160W

NOTES

- Samsung Electronics Co., Ltd reserves the right to change the specifications without notice.
- Weight and dimensions are approximate.
- Dispose unwanted electronics through an approved recycler.
To find the nearest recycling location, go to our website: www.samsung.com/recyclingdirect.

REFURBISHED PRODUCT LIMITED THIRTY DAY WARRANTY

The **Refurbished Product Service Center** offers the following WARRANTY to the ORIGINAL purchaser of a product which we have refurbished. This product that has been refurbished is warranted against any electronic or mechanical defects for a period of THIRTY DAYS from the date of the original purchase by the consumer. Since this unit was sold as a refurbished item, the warranty does not apply to any cosmetic appearance items such as scratches. Should a defect occur, the **Refurbished Product Service Center** will repair or, at its option, replace defective unit/parts with new or rebuilt materials without charge for either parts or labor. Replacement unit/parts will be warranted for the remaining portion of the original warranty period.

This warranty does not cover installation or damage from accident, misuse, abuse, improper wiring, incorrect voltage, operating the unit against the instructions in the owner's manual or any product which has been opened, altered, or tampered with.

This warranty does not cover costs for removal and or installation of the unit for repair. Under no circumstances shall the service center be liable for any special, incidental or consequential damages or for any other expenses incurred by reason of use or sale of this product. This warranty is in lieu of any other warranties expressed or implied warranty of merchantability of fitness for particular use or otherwise.

This warranty gives the consumer specific legal rights and they may also have other rights which vary from State to State. Some States do not follow the exclusion or limitation of incidental or consequential damages, hence the above exclusion and limitations may not apply.

Refurbished Product Service Center
13225 Marquardt Avenue Santa Fe Springs, CA 90670

WARRANTY REPAIR INFORMATION

If you need service on your unit during the 30 day warranty period; please go to www.ConsumerServiceRefurbish.com or call the Refurbished Product Service Center at 562-946-3531 to obtain the required claim number. Once you obtain your claim number, pack the unit properly (the original carton is ideal for this purpose) along with a copy of your purchase receipt.

Send the unit freight prepaid and insured to:

Refurbished Product Service Center,
Att: Customer Service Department 13225 Marquardt Avenue Santa Fe Springs, CA 90670

Your unit will be promptly exchanged and returned to you. We will refuse to accept delivery of the returned unit unless the assigned claim number appears on the outside of the shipping carton.

Owner's Information
(Keep for your permanent records)

NAME: _____

ADDRESS: _____

CITY: _____ STATE: _____ ZIP CODE: _____

PHONE: _____ E-MAIL: _____

MODEL: _____ SERIAL NO.: _____

LICENSE



804106425A



PRINTED IN MEXICO / SC.21-09-2021

OBNP: NSPBI00373A-01

SHNMDL: HWQ6CR_B

TAB/Elbrd: J.E.