

IMPORTANT SAFEGUARDS

When using electrical appliances, basic safety precautions should always be followed, including the following:



1. READ ALL INSTRUCTIONS

- For household use only.
- Do not fill water reservoir above max fill line or use distilled water.
- Scalding may occur if the handle or filter basket cover is opened during the brewing process.
- Do not touch hot surfaces. Use handles or knobs.
- To protect against fire, electric shock, and injury to persons do not immerse appliance, cord, or plugs in water or other liquid.
- Close supervision is necessary when any appliance is used by or near children 12 years or younger.
- Unplug from outlet when not in use and before cleaning. Allow to cool before putting on or taking off parts, and before cleaning the appliance.
- Do not operate any appliance with a damaged cord or plug or after the appliance malfunctions, or has been damaged in any manner. Contact a service center.
- The use of accessory attachments not authorized by the appliance manufacturer may result in fire, electric shock, or injury to persons.
- Do not use outdoors.
- Do not let cord hang over edge of table or counter, or touch hot surfaces.
- Do not place on or near a hot gas or electric burner, or in a heated oven.
- Always attach plug to appliance first (if not permanently attached), then plug cord into the wall outlet. To disconnect, turn any control to “off” (if applicable) then remove plug from wall outlet.
- Do not use appliance for other than intended use.
- Use brewer in upright position only. Allow brewer to cool (90 min) prior to turning it in any position other than upright.
- The glass carafe is designed for use with this appliance. It must never be used on a range top.
- Do not set a hot carafe on a wet or cold surface.
- Do not use a cracked carafe or a carafe having a loose or weakened handle.
- Do not clean carafe with abrasive cleansers, steel wool, or other abrasive material.
- Only use K-Cup® pods intended for this appliance. If the pod does not fit, do not force it into the appliance.

22. SAVE THESE INSTRUCTIONS

- WARNING:** Keep all plastic bags away from children.
- WARNING:** Always make sure the carafe is positioned properly to accept the dispensed hot liquid. Overflow can lead to scalding hazards.
- WARNING:** Used K-Cup® pods should be removed from the pod holder, and areas holding coffee grounds should be rinsed clean after brewing, or in part with the daily cleaning routine.
- WARNING:** Do not open filter basket cover while brewing is in progress.
- WARNING:** Snap lid securely onto carafe before serving any beverages.
- WARNING:** Scalding may occur if the carafe lid is removed during brew cycle.
- CAUTION:** Keurig recommends using only Keurig® My K-Cup® Reusable Coffee Filters and Keurig® K-Cup® pods in this appliance. **Do not remove foil lid.** The use of non-Keurig® pods or accessories may cause brewer malfunction or injury.
- CAUTION:** There are sharp needles that puncture the K-Cup® pod; one above the K-Cup® pod holder and the other in the bottom of the K-Cup® pod holder. To avoid risk of injury, be aware of the needle locations.
- WARNING:** There is extremely hot water under pressure in the K-Cup® pod holder during the brew process. To avoid risk of injury do not lift the handle or otherwise open the handle during the brew process.
- POWER CORD INSTRUCTIONS:**
 - A short power-supply cord is provided to reduce risks resulting from becoming entangled in or tripping over a longer cord.
 - Longer detachable power-supply cords or extension cords are available and may be used if care is exercised in their use.
 - If a long detachable power-supply cord or extension cord is used:
 - The marked electrical rating of the detachable power-supply cord or extension cord should be at least as great as the electrical rating of the appliance.
 - If the appliance is of the grounded type, the extension cord should be a grounding type 3-wire cord.
 - The longer cord should be arranged so that it will not drape over the counter top or table top where it can be pulled on by children or tripped over.

- CAUTION: HOT COCOA/OTHER NON-COFFEE PODS:** Immediately after using a hot cocoa/other non-coffee pod, run a hot water brew cycle without a pod to avoid the possibility of clogging the exit needle. **DO NOT** assume the next user will do this.



Button Overview

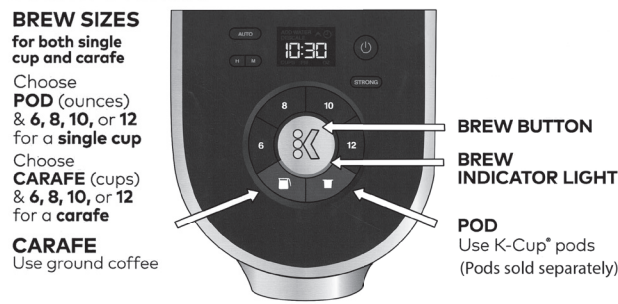

NOTE: The image shown here is for illustrative purposes only and may be subject to change. The actual descriptions of control panel and their locations may vary, depending on the model.

Before You Brew



1 Plug & Place

Remove packing tape from brewer and plug into an outlet.

Single Cup - Place a large mug (12oz minimum) on the drip tray.

Carafe - Rinse the carafe and place it on the heating plate.



2 Rinse & Fill

Remove the water reservoir lid, then lift the reservoir straight up to remove it.

If you have a Keurig® Water Filter, install it now. Refer to your Water Filter Starter Kit for instructions.

Fill the reservoir with fresh water to the **MAX** fill line.

Replace water reservoir, making sure the lock tabs engage with the brewer.

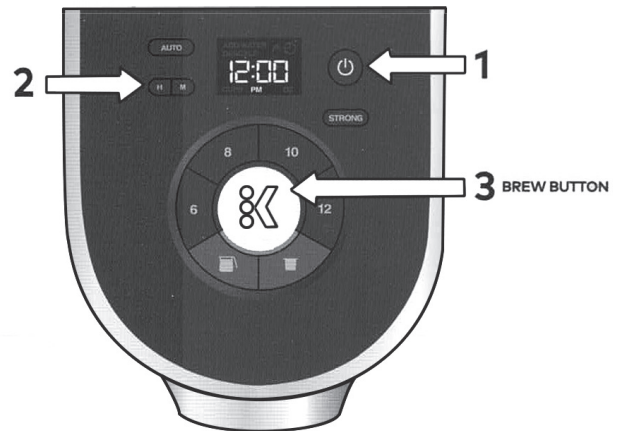

3 Power On & Set Clock

Press the **POWER** button. Use the **H/M** buttons to set the clock, then press the blinking **BREW** button to confirm the time.

NOTE: The clock must be set in order to use the Auto Brew functionality.



4 Cleansing Brew - Single Cup

Press the **POD** button - the 4 brew size buttons will blink. **Do not insert a K-Cup® pod.** Press the **8** button - the brew indicator light will blink. Press the **BREW** button to start the cleansing brew.

The cleansing brew will begin once the brewer is heated. The initial heating process will take about 4 minutes. The brew indicator light will pulse while the brewer is heating and will turn solid when ready.

The brew is complete when the brew indicator light is no longer illuminated. Pour the hot water into the sink.

NOTE: Between brew cycles, the brewer may take about a minute to reheat



5 Cleansing Brew - Carafe

Do not fill the filter basket with coffee grounds. Press the **CARAFE** button - the 4 brew size buttons will blink, press the **8** button. The brew indicator light will blink. Press the **BREW** button to start the cleansing brew.

NOTE: In order to ensure the highest possible standard for refurbished items, all units are thoroughly inspected as part of the process. For this item, water may be used during the refurbishing process and so; you may notice some condensation in the water reservoir. It is recommended to rinse the water reservoir with fresh water prior to its first use.

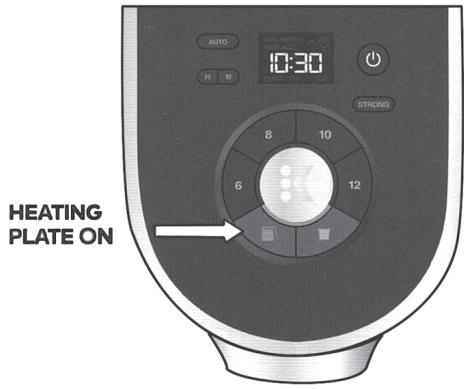

The **CARAFE** button will illuminate red to indicate the heating plate is on when the cleansing brew is complete. Press and hold the **CARAFE** button to turn the heating plate off, and pour the hot water into the sink.

Brew Your First Single Cup



1 Place Mug & Pod

Place a mug on the drip tray. If using a travel mug, remove the drip tray and place the mug on the drip tray base. Lift the handle and place a K-Cup® pod in the K-Cup® pod holder. Lower the handle completely to close the lid.

High Altitude Brewing: While holding the brewer handle up, push down slowly on the K-Cup® pod in the pod holder until the bottom of the K-Cup® pod is punctured by the exit needle.

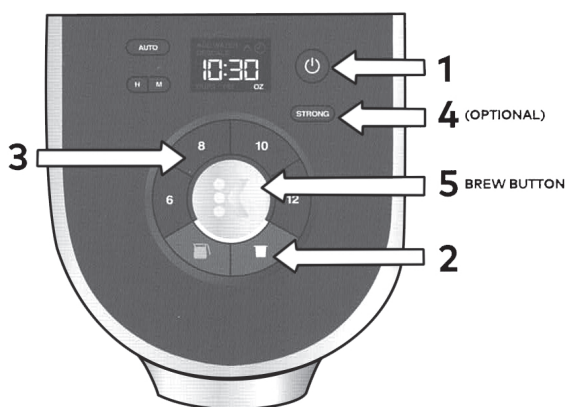

2 Brew & Enjoy!

Press the **POWER** button. The **POD** and **CARAFE** buttons will blink. Select **POD**, then select your brew size. Press the **BREW** button to initiate brewing. For a bolder coffee, press the **STRONG** button before pressing the **BREW** button.

Brewing is complete when the brew indicator light is no longer illuminated.

We recommend using a Keurig® Rinse Pod or running a cleansing brew immediately after brewing hot cocoa or other sweetened pods to keep the needles clean.

NOTE: After 5 minutes, the brewer will go into Auto Off mode. To reactivate, press the **POWER** button.

Brew Your First Carafe

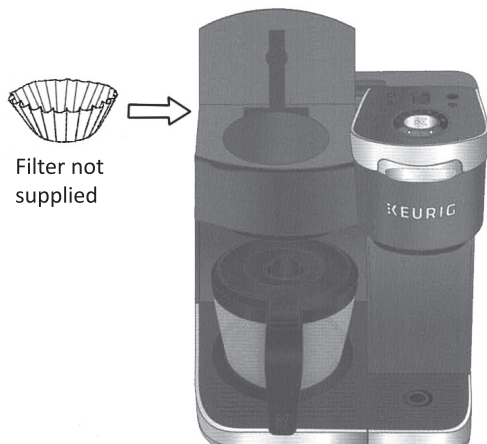

1 Place Carafe & Fill Basket

Fill the water reservoir to the **MAX** fill line. Lift the filter basket cover up and insert a 12 cup paper filter into the filter basket. Add the desired amount of ground coffee (1 tablespoon of ground coffee per cup is recommended). Close the filter basket cover completely and make sure the carafe is on the heating plate.

NOTE: The maximum capacity for regular ground coffee is 15 tablespoons and 12 tablespoons for decaf. Exceeding this amount may cause overflow.

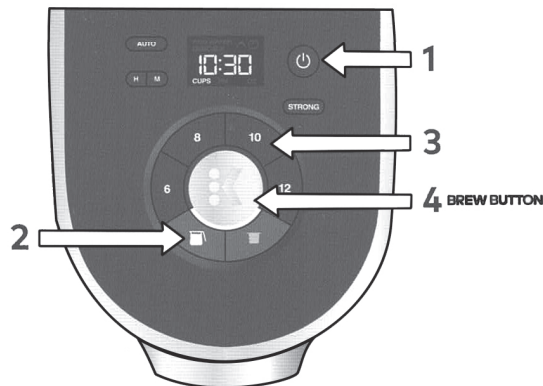

2 Brew & Enjoy!

Press the **POWER** button. The **POD** and **CARAFE** buttons will blink. Select **CARAFE**, then select your brew size. Press the **BREW** button to initiate brewing.

Once the brew is complete, the heating plate will automatically turn on and remain on for 2 hours - the **CARAFE** button will illuminate red. To turn off the heating plate, press and hold the **CARAFE** button until the light is no longer illuminated.

If you accidentally shut the heating plate off, press and hold the **CARAFE** button until the red light illuminates to turn it back on.

NOTE: The images shown here are for illustrative purposes only and may be subject to change.

Brewer Features

Smart Start heats then brews in one simple process. No need to wait for the brewer to heat before selecting brew size. Power on your brewer, add coffee, select your brew type, then select your brew size. Press the brew button. The brewer will heat, then automatically begin brewing.

Single Cup Auto Off automatically turns your brewer off 5 minutes after the last brew for energy savings.

Carafe Auto Off automatically turns your heating plate off 2 hours after the last brew for energy savings.

Auto Brew programs the carafe to brew at a specific time up to 24 hours in advance. See full Use & Care Guide for instructions.

Strong Brew increases your coffee strength and intensity for a single cup. For bolder coffee, press the **STRONG** button.

High Altitude To ensure your brewer works properly at higher altitudes (5,000 feet), enable the High Altitude setting by pressing and holding the **POD** and **CARAFE** button for 3 seconds. When enabled, a mountain icon  will appear on the display screen.

Pause & Pour a cup mid-brew while brewing a carafe using the 20 second automatic pause feature.

NOTE: Removing the carafe for more than 20 seconds may cause the filter basket to overflow.

Brew & Pause during a carafe brew by pressing the **CARAFE** button. Press the **CARAFE** button to resume the brew.

Caring for your Brewer

Regular cleaning keeps your brewer running smoothly. Always be sure to unplug your brewer and allow it to cool before cleaning.

If the brewer has been in storage, or hasn't been used in days, run a cleansing brew before brewing your beverage.

Periodically **hand-wash** the water reservoir and lid, carafe and lid, drip tray, and filter basket with warm soapy water and rinse clean.

CAUTION: Parts are not dishwasher safe.

NOTE: Do not dry the inside of the water reservoir with a cloth as lint may remain.

Troubleshooting

If the 8, 10, and 12 button lights all blink simultaneously, contact Service center.

If the 8, 10, and 12 button lights all illuminate solid simultaneously, lift handle and remove K-Cup® pod (if present in the brewer). Close handle and place a large mug on the drip tray. Press the **POD** button once. The brewer may dispense hot water and the lights will turn off.

Auto Brew Instructions

Fill the water reservoir to **MAX** fill line and load the paper filter and coffee grounds.

1. Press the **AUTO** button. Use the **H/M** buttons to set the time for auto brew to begin, press the blinking **BREW** button to confirm the time.
2. Choose your brew size, then press the blinking **BREW** button to confirm the size.
3. **The AUTO brew setup is now complete.** A **clock icon** will appear on the screen and the **AUTO** button will be illuminated to signal AUTO is on.

NOTE: Once AUTO brew is enabled, you will only be able to brew a single cup. To disable AUTO brew, press the **AUTO** button once. The **clock icon** will disappear from the screen.

Descaling

Descal your brewer every 3 months (or if you experience low coffee volume or slower performance).

REFURBISHED PRODUCT LIMITED THIRTY DAY WARRANTY

The **Refurbished Product Service Center** offers the following WARRANTY to the ORIGINAL purchaser of a product which we have refurbished.

This product that has been refurbished is warranted against any electronic or mechanical defects for a period of THIRTY DAYS from the date of the original purchase by the consumer. Since this unit was sold as a refurbished item, the warranty does not apply to any cosmetic appearance items such as scratches. Should a defect occur, the **Refurbished Product Service Center** will repair or, at its option, replace defective unit/parts with new or rebuilt materials without charge for either parts or labor. Replacement unit/parts will be warranted for the remaining portion of the original warranty period.

This warranty does not cover installation or damage from accident, misuse, abuse, improper wiring, incorrect voltage, operating the unit against the instructions in the owner's manual or any product which has been opened, altered, or tampered with.

This warranty does not cover costs for removal and or installation of the unit for repair. Under no circumstances shall the service center be liable for any special, incidental or consequential damages or for any other expenses incurred by reason of use or sale of this product. This warranty is in lieu of any other warranties expressed or implied warranty of merchantability of fitness for particular use or otherwise.

This warranty gives the consumer specific legal rights and they may also have other rights which vary from State to State. Some States do not follow the exclusion or limitation of incidental or consequential damages, hence the above exclusion and limitations may not apply.

Refurbished Product Service Center
13225 Marquardt Avenue Santa Fe Springs, CA 90670

WARRANTY REPAIR INFORMATION

If you need service on your unit during the 30 day warranty period; please go to www.ConsumerServiceRefurbish.com or call the Refurbished Product Service Center at 562-946-3531 to obtain the required claim number. Once you obtain your claim number, pack the unit properly (the original carton is ideal for this purpose) along with a copy of your purchase receipt. Send the unit freight prepaid and insured to:

Refurbished Product Service Center,
Att: Customer Service Department 13225 Marquardt Avenue
Santa Fe Springs, CA 90670

Your unit will be promptly exchanged and returned to you. We will refuse to accept delivery of the returned unit unless the assigned claim number appears on the outside of the shipping carton.

Owner's Information
(Keep for your permanent records)

NAME: _____

ADDRESS: _____

CITY: _____ STATE: _____

ZIP CODE: _____ PHONE: _____

E-MAIL: _____

MODEL: _____ SERIAL NO.: _____

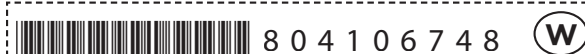

PRINTED IN MEXICO Elbrd: M.C. OBPB: DC000002749 Rev E
SC: 10-17-2022_TAB SHNMDL: KEURIGK-DUO5100